



 **Snow Load**
75 kg/m²
15 lbs/ft²

 **Wind Resistant**
90 km/hr
55 mi/hr

Assembly Instructions

Skylight Shed™ - 6x12

Approx. Dim.

380L x 185.5W x 217H cm / 149.6"L x 73"W x 85.4"H

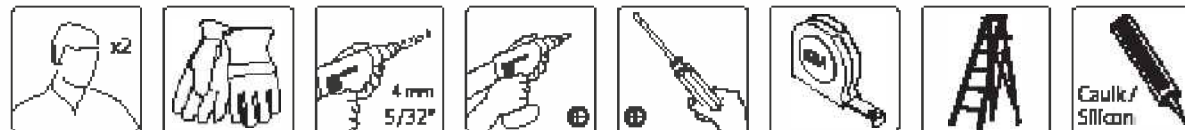
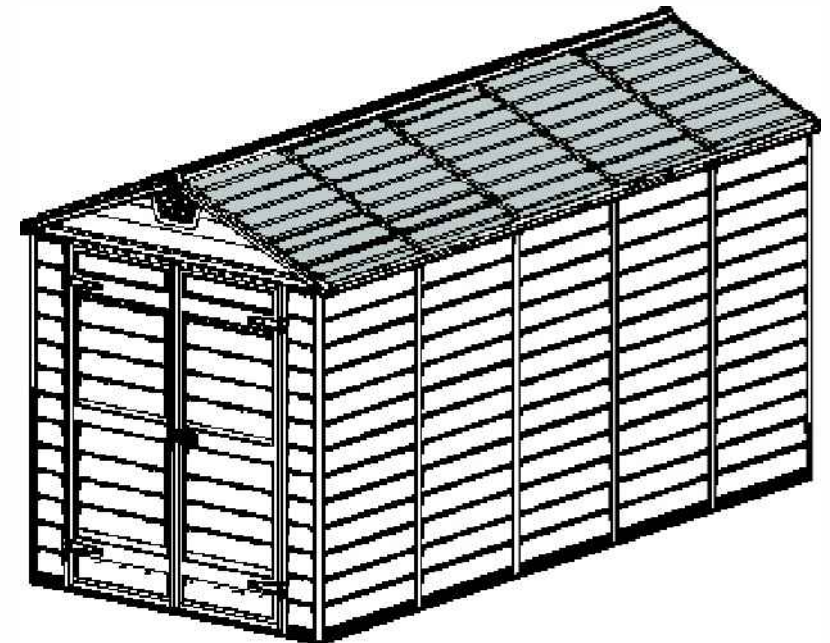

After Sale Service

Email: customer.service@palram.com

USA 877-627-8476
Canada 1 800-866-5749

England 01302-380775
Germany 0180-522-8778

France 0169-791-094
International +972 4-848-6942

www.palramapplications.com

IMPORTANT

Please read these instructions carefully before you start to assemble this shed.
Please carry out the steps in the order set out in these instructions.
Keep these instructions in a safe place for future reference.

Tools & Equipment

T001 - (supplied)

(these items not supplied)

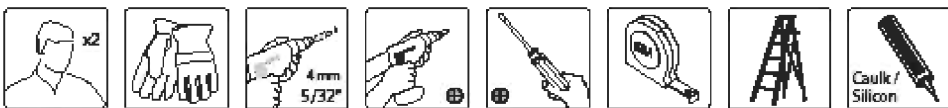
**Safety**

- This shed must be placed and fixed on a leveled surface to ensure its stability. Make sure that screws and anchors are compatible with surface type.
- Some parts have metal edges. Please be careful when handling components.
- Always wear gloves, eye protection, and long sleeves when assembling or performing any maintenance on your shed.
- Do not attempt assembly on days with strong winds or low temperatures. If using a stepladder or power tools ensure that you follow the manufacturer's safety advice.
- Do not stand on the roof.
- Do not store hot items such as recently used grills, blowtorches etc. in the shed.
- Heavy or sharp articles should not be leaned against the wall panels.
- To prevent suffocation, do not allow children to play with packing materials.
- Shed must be secured by drilling through floor panels holes locations and inserting suitable screws into ground

Before you start

- Consult your local authorities for any building limitations or permits required to construct this garden shed.
- Complete site preparation before unpacking parts and beginning assembly.
- It is highly recommended to be assisted by a second person in some steps.
- Sort the parts and check against the contents parts list.
- Please take safety precautions during assembly.

During Assembly

When encountering the information icon, please refer to the relevant assembly step for additional comments and assistance.



This icon indicates that the installer should be inside the product.



This icon indicates that the installer should be outside the product.

**Attention:**

- It is important to drill the screws at the top of the panel ridge and to make sure that screws penetrate through the panel in order to have maximum durability.
- Make sure to position the panel's bottom ridge towards the shed floor and that it is enclosing it.

Step 3: Place the first wall panel at the back of the shed, according to the stamped serial number (**part 7699**).

Step 29: Please apply silicone (caulk) sealant at the connection between both Aluminum profiles (diagram b), in order to prevent water from seeping in.

Step 39: Note that panels and profiles connected in the right direction as well as the profiles holes placed correctly as illustrated.

Step 46: Anchor the shed on to a solid surface such as concrete or asphalt, use suitable screws and plugs. (Screws and plugs are not supplied).

*Please note: Anchoring this product to the ground is essential to its stability and rigidity. It is required to complete this stage in order for your warranty to be valid.

Do not tighten screws and nuts (411 & 412) until completion of assembly process. These 2 icons indicate if screws' tightening is required or not.

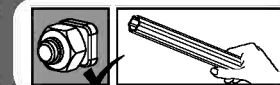

412



411



IMPORTANT

Veillez lire ces instructions attentivement avant de commencer à assembler cet abri. Veillez suivre les étapes indiquées dans ces instructions. Conservez ces instructions dans un endroit sûr pour usage ultérieur.

Vous aurez besoin

T001 - (fourni)

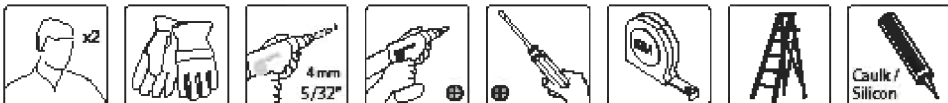

(Ces articles ne sont pas fournis)

Sécurité

- Cet abri doit être placé et fixé à une surface nivelée pour garantir sa stabilité. Veillez à ce que les écrous et les ancrages soient compatibles avec le type de surface.
- Certaines pièces ont des bords métalliques. Faites attention en utilisant les pièces.
- Portez toujours des gants, des lunettes de protection et des manches longues pour monter ou réaliser une action de maintenance sur votre abri.
- Ne tentez pas de monter un jour de vent fort ou de basse température. Si vous utilisez un escabeau ou de l'outillage électrique, veillez à suivre les recommandations de sécurité du fabricant.
- Ne vous tenez pas sur le toit.
- N'entreposez pas des objets chauds comme des grills récemment utilisés, des chalumeaux, etc... dans l'abri.
- Des articles lourds ou pointus ne doivent pas être posés contre les panneaux muraux.
- Pour éviter tout étouffement, ne laissez pas les enfants jouer avec les matériaux d'emballage.
- Abri doit être fixé par le forage à travers des panneaux de plancher trous endroits et l'insertion des vis adéquates dans le sol

Avant de commencer

- Consultez les autorités locales concernant les limites ou les permis de construction nécessaires pour construire cet abri de jardin.
- Complétez la préparation du site avant de déballer les parties et de commencer le montage.
- Il est fortement recommandé de vous aider d'une seconde personne pour certaines étapes.
- Ordonnez les pièces et vérifiez-les avec la liste des pièces contenues.
- Veillez prendre des précautions de sécurité pendant le montage.

Pendant le montage

Lorsque vous voyez l'icône Information, veillez regarder l'étape de montage pertinente pour voir des commentaires et une assistance supplémentaires.



Cette icône indique que l'installateur doit être à l'intérieur du produit



Cette icône indique que l'installateur doit être en dehors du produit.

**Attention:**

- Il est important de visser les écrous en haut de la crête du panneau et de vous assurer que les vis pénètrent à travers le panneau afin d'obtenir une durabilité maximale.
- Assurez-vous de positionner la crête inférieure du panneau vers le sol de l'abri et qu'il le referme.

Étape 3: Placez le premier panneau mural au dos de l'abri, selon le numéro de série marqué (pièce 7699).

Étape 29: appliquez un enduit de silicone (colmatage) à la jonction entre les deux profils en aluminium (schéma b), afin d'éviter les infiltrations d'eau.

Étape 39: Remarquez que les panneaux et les profils sont connectés dans la bonne direction ainsi que les trous des profils qui sont placés correctement comme illustré.

Étape 46: Ancrez l'abri sur une surface solide comme du béton ou de l'asphalte, utilisez des vis et des chevilles adaptées. (Les vis et les chevilles ne sont pas fournies).

* Veuillez noter : cette étape d'ancrage du produit au sol est essentielle à sa stabilité et à sa rigidité, elle est de plus nécessaire pour assurer la validité de votre garantie.

Ne serrez pas les vis et les boulons (411 & 412) jusqu'à la fin du processus de montage. Ces 2 icônes indiquent s'il est nécessaire de serrer les écrous ou non.

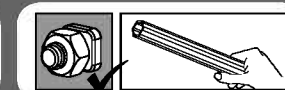
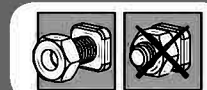

WICHTIG

Bitte lesen Sie die vorliegenden Anweisungen sorgfältig durch, bevor Sie mit dem Zusammenbau dieses Schuppens beginnen. Bitte führen Sie die Schritte in der in der vorliegenden Anleitung aufgeführten Reihenfolge aus. Bewahren Sie die Anleitung für eine spätere Bezugnahme an einem sicheren Ort auf.

Sie werden brauchen

T001 - (Werkzeuge)

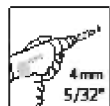

(Diese Artikel werden nicht mitgeliefert)

Sicherheit

- ✓ Dieser Schuppen muss auf einer ebenen Oberfläche aufgestellt und verankert werden, um seine Stabilität zu gewährleisten. Bitte vergewissern Sie sich, dass die Schrauben und Verankerungen der Art des Bodens entsprechen.
- ✓ Einige Teile haben Metallkanten. Bitte lassen Sie bei der Handhabung der Bauteile Vorsicht walten.
- ✓ Tragen Sie immer Handschuhe, Augenschutz und lange Ärmel, wenn Sie Ihren Schuppen zusammenbauen oder an ihm Instandhaltungsarbeiten durchführen.
- ✓ Versuchen Sie nicht, den Schuppen an Tagen mit starkem Wind oder niedrigen Temperaturen zu montieren. Wenn Sie eine Stehleiter oder elektrische Werkzeuge einsetzen, stellen Sie bitte sicher, dass Sie den Sicherheitshinweisen des Herstellers folgen.
- ✓ Stehen Sie nicht auf dem Dach.
- ✓ Lagern Sie keine heißen Gegenstände, wie zum Beispiel etwa vor kurzem benutzte Grillgeräte, Schneidbrenner, etc. in dem Schuppen.
- ✓ Schwere oder scharfkantige Gegenstände sollten nicht gegen die Wandpaneele gelehnt werden.
- ✓ Um Erstickungsunfälle zu vermeiden, gestatten Sie Kindern nicht, mit dem Verpackungsmaterial zu spielen.
- ✓ Shed muss durch Bohren durch Bodenplatten Löcher Standorte und geeigneten Schrauben in den Boden gesichert werden

Ziehen Sie die Schrauben und Muttern (411 & 412) nicht fest, bevor Sie den Montagevorgang abgeschlossen haben. Diese beiden Symbole zeigen an, ob ein Festziehen der Schrauben erforderlich ist oder nicht.

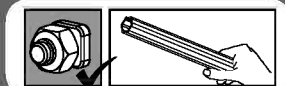

412



411

**Bevor Sie beginnen**

- ✓ Consult Fragen Sie bei den örtlichen Behörden nach, ob es irgendwelche Einschränkungen für den Aufbau gibt oder Genehmigungen erforderlich sind, um diesen Gartenschuppen aufzustellen.
- ✓ Der Schuppen muss auf einer ebenen Fläche aufgestellt und verankert werden. Schließen Sie die Vorbereitung des Standortes ab, bevor Sie die Bauteile auspacken und mit dem Zusammenbau beginnen.
- ✓ Es wird dringend empfohlen, bei einigen Montageschritten die Hilfe einer zweiten Person in Anspruch zu nehmen.
- ✓ Sortieren Sie die Teile, und vergleichen Sie diese mit der Liste der in der Packung enthaltenen Teile.
- ✓ Bitte nehmen Sie im Verlauf des Zusammenbaus Sicherheitsmaßnahmen vor.

Im Verlauf des Zusammenbaus

Wenn Sie auf das Informationssymbol treffen, sehen Sie sich bitte den relevanten Montageschritt für weitere Kommentare und Hilfe an.



Dieses Symbol zeigt an, dass sich die installierende Person sich im Inneren des Produktes befinden sollte.



Dieses Symbol zeigt an, dass die installierende Person sich außerhalb des Produktes befinden sollte.

**Achtung:**

- ✓ Es ist wichtig, die Schrauben an der oberen Seite der Paneelkante einzudrehen und sich zu vergewissern, dass die Schrauben das Paneel durchdringen, um eine größtmögliche Strapazierfähigkeit zu gewährleisten.
- ✓ Bitte vergewissern Sie sich, dass Sie die untere Kante des Panels in die Richtung des Schuppenbodens positionieren, und dass es den Boden einfasst.

Schritt 3: Platzieren Sie das erste Wandpaneel an der Rückseite des Schuppens, im Einklang mit der aufgedruckten Seriennummer (**Teil 7699**).

Stap 29: Breng siliconenkit aan op de verbinding tussen de beide aluminium profielen (diagram b) om te voorkomen dat er water naar binnen sijpelt.

Schritt 39: Bitte beachten Sie, dass Paneele und Profile in der richtigen Richtung miteinander verbunden und ebenso die Öffnungen für die Profile korrekt platziert sind, entsprechend der Illustration.

Schritt 46: Verankern Sie die Hütte auf einem festen Untergrund wie Beton oder Asphalt mittels anmessener Schrauben und Dübeln. (Schrauben und Dübel sind nicht mitgeliefert).

*Bitte beachten Sie: Die Verankerung dieses Produkts im Untergrund ist wesentlich für seine Stabilität und Festigkeit. Sie ist unablässlich, um diesen Arbeitsschritt zu beenden, damit Ihre Garantie gültig bleibt.

IMPORTANTE:

Lea cuidadosamente estas instrucciones antes de comenzar a ensamblar el producto. Por favor siga el orden que estas instrucciones indican. Guarde este instructivo en un lugar seguro para futuras consultas.

Usted necesitará:

T001 - (incluido)

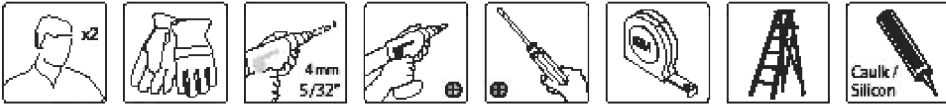

(estos artículos no están incluidos)

Seguridad:

- Este cobertizo debe colocarse y fijarse en una superficie plana para asegurar su estabilidad.
- Asegúrese que los tornillos y anclas sean compatibles con el tipo de superficie.
- Algunos componentes tienen puntas de metal. Manéjelos con cuidado al instalarlos.
- Siempre utilice guantes, lentes de protección y mangas largas a la hora de instalar o realizar cualquier mantenimiento al cobertizo.
- No realice el montaje del producto en días con mucho viento o temperaturas bajas. Si utiliza escalera de tijera o herramientas eléctricas, asegúrese de seguir las recomendaciones de seguridad del fabricante.
- No se pare en el techo del cobertizo.
- No almacene artículos calientes en el cobertizo como por ejemplo, taladros que acaban de ser utilizados, sopletes, etc.
- No recargue artículos muy pesados o puntiagudos en las paredes del producto.
- Para evitar casos de asfixia, no deje que los niños jueguen con el material de empaque de los componentes.
- El cobertizo debe ser fijado al piso a través de los orificios en los paneles correspondientes e insertando tornillos compatibles al tipo de suelo.

Antes de empezar:

- Consulte las limitaciones, requisitos, permisos y a las autoridades locales para la construcción de este cobertizo de jardín.
- Prepare el lugar de instalación y fijación antes de desempacar los componentes.
- Es muy recomendable y/o necesaria la asistencia de una segunda persona en algunos pasos del ensamblaje

- Ordene los componentes y revíselos contra la lista de contenidos del producto.
- Siempre diríjase con precaución y cuidado durante la instalación.

Durante la instalación

Cuando encuentre el ícono de información, por favor lea con cuidado dicho paso con comentarios y asistencia adicionales.



Este ícono indica que el instalador debe estar dentro del producto.



Este ícono indica que el instalador debe estar fuera del producto.

Atención:

- Es muy importante que los tornillos sean taladrados en la parte superior del panel y asegurarse de que el tornillo penetre todo el panel para máxima durabilidad.
- Asegúrese de colocar adecuadamente la parte inferior del panel contra el piso del producto y esté fijado completamente a él.

Paso 3: Coloque la primer pared o panel en la parte posterior del cobertizo, de acuerdo al número de serie indicado como **Part 7699**.

Paso 29: por favor, aplique sellante de silicona (para calafatear) en la conexión entre ambos perfiles de aluminio (diagrama b), para evitar que el agua se filtre.

Paso 39: Todos los paneles y perfiles deben ser conectados en la dirección correcta, al igual que los orificios de los perfiles, como la ilustración lo indica.

Paso 46: Ancle el cobertizo a una superficie sólida como hormigón o asfalto, utilice tornillos y tapones adecuados. (No se suministran los tornillos y tapones).

*Por favor, tenga en cuenta: Anclar este producto al suelo es esencial para su estabilidad y rigidez. Es necesario completar esta fase para que su garantía sea válida.

No apretar los tornillos y tuercas (411 y 412) hasta que termine el proceso de ensamble. Los siguientes 2 íconos le indicarán si el ajuste de los tornillos es necesario o no.

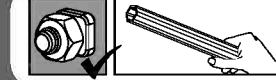

VIGTIGT

Læs venligst denne vejledning grundigt, før du påbegynder monteringen af skuret. Udfør venligst trinnene i den rækkefølge, der er angivet i vejledningen. Opbevar denne vejledning på et sikkert sted for fremtidig konsultation.

Du skal bruge

T001 - (Inkluderet)

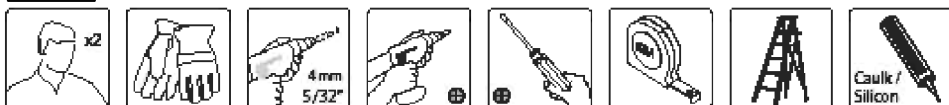

(disse genstande medfølger ikke)

Sikkerhed

- Skuret skal placeres på eller fastgøres til en plan overflade, så dets stabilitet sikres. Sørg for, at skruer og rawlplugs passer til overfladetyper.
- Nogle dele har metalkanter. Vær forsigtig under håndteringen af komponenterne.
- Brug altid handsker, øjeværn og lange ærmer, når du monterer eller udfører vedligeholdelse på dit skur.
- Forsøg ikke at samle skuret på dage med stærk blæst eller lave temperaturer. Hvis du anvender en trappestige eller el-værktøj, skal du følge producentens sikkerhedsvejledning.
- Stå ikke på taget.
- Opbevar ikke varme genstande i skuret, så som griller og skærebrænder, der er anvendt kort forinden.
- Tunge eller skarpe genstande må ikke lænes op ad vægpanelerne.
- For at undgå kvælning må børn ikke lege med emballagematerialerne.
- Skuret skal sikres ved, at der bores gennem gulvpanelerne, hvor hullerne skal være, og der sættes passende skruer i underlaget.

Før du starter

- Undersøg hos dine lokale myndigheder, om der forefindes begrænsninger for eller kræves tilladelser til at bygge dette haveskur.
- Klargør monteringsstedet helt, før du udpakker delene og påbegynder monteringen.
- Det anbefales i høj grad at du lader en anden person assistere dig under udførelsen af nogle af trinnene.
- Sortér delene, og tjek dem i forhold til indholdslisten over delene.
- Sørg for at tage de rette sikkerhedsforholdsregler under monteringen.

Under monteringen

Når du støder på informationsikonet, bedes du venligst se det relevante monteringstrin for yderligere kommentarer og hjælp.



Dette ikon indikerer, at installatøren skal befinde sig inde i for produktet



Dette ikon indikerer, at installatøren skal befinde sig uden for produktet

**OBS:**

- Det er vigtigt, at skruerne skrues i øverst på panelets kant, samt at skruerne går igennem panelet, så der sikres maksimal holdbarhed.
- Sørg for, at panelets underkant placeres mod skurets gulv og omslutter det.

Trin 3: Placér det første vægpanel bagerst i skuret, i henhold til det trykte serienummer (**del 7699**).

Trin 29: Påfør silikonefugemasse (tætningsmateriale) mellem de to aluminiumsprofiler (diagram b) for at forhindre vand i at sive ind.

Trin 39: Vær opmærksom på, at panelet og profilerne er forbundet i den rigtige retning, samt at profilens huller er placeret korrekt som på illustrationen

Trin 46: Du skal forankre skuret på en fast overflade, såsom beton eller asfalt, ved hjælp af egnede skruer og møtrikker. (Skruer og møtrikker medfølger ikke).

***Bemærk venligst:** Forankring af dette produkt til jorden er afgørende for dets stabilitet og styrke. For at sikre gyldigheden af din garanti, kræves det, at du gennemfører dette trin.

Stram ikke skruer og møtrikker (411 og 412), før monteringsproceduren er afsluttet. Disse 2 ikoner indikerer, om skruerne skal strammes eller ej

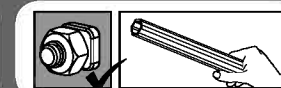
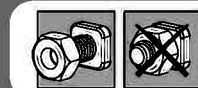

DŮLEŽITÉ

Dříve než začnete kůlnu sestavovat, přečtěte si pozorně tyto instrukce. Dodržujte postup v pořadí, v jakém je uveden v těchto instrukcích. Uložte si tyto instrukce na bezpečné místo pro budoucí použití.

Budete potřebova

T001 - (poskytnout)

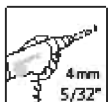

(tyto položky nejsou součástí dodávky)

Bezpečnost

- Tato kůlna musí být umístěna a zajištěna na vyvýšeném povrchu, aby bylo možné zajistit stabilitu.
- Ujistěte se, že šrouby a kotvy jsou kompatibilní s typem povrchu.
- Některé části mají kovové okraje. Při manipulaci se součástkami buďte opatrní.
- Při sestavování nebo údržbě kůlny noste vždy rukavice, chrániče očí a dlouhé rukávy. Nepokoušejte se kůlnu sestavovat při velkém větru nebo za chladného počasí. Pokud používáte
- štafle nebo elektrické nástroje, ujistěte se, že dodržujete bezpečnostní doporučení výrobce.
- Nestoupejte si na střechu.
- Neukládejte horké položky jako jsou nedávno používaný gril, letovací lampa, atd.
- Těžké nebo ostré předměty by neměly být položeny směrem ke zdi.
- Pro vyhnutí se riziku udušení, nedovolte dětem, aby si hrály s obaly.
- Bouda musí být zajištěn provrtání stropní panely otvory místa a vložení vhodných šroubů do země

Než začnete

- Informujte se u místních orgánů na případná stavební omezení nebo požadovaná povolení pro výstavbu této zahradní kůlny.
- Než vybalíte jednotlivé díly a začnete kůlnu sestavovat, připravte si prostor, kam ji umístíte.
- Velmi se doporučuje, abyste při některých krocích měli k ruce druhého člověka.
- Vyndejte jednotlivé součástky a zkontrolujte obsah dle seznamu součástek.
- Při sestavování dodržujte bezpečnostní instrukce.

Během sestavování

Jakmile narazíte na informační ikonu, podívejte se na příslušný krok, kde najdete další komentáře a rady.



Tato ikona ukazuje, že osoba sestavující kůlnu by měla být uvnitř objektu



Tato ikona ukazuje, že člověk sestavující kůlnu by se měl nacházet vně objektu.

**Pozor:**

- It Je důležité zavrtat šrouby na horní hřbet panelu a ujistit se, že šrouby prošly panelem a budou mít maximální výdrž.
- Ujistěte se, že spodní hřbet panelu leží na podlaze kůlny a že ji uzavírá.

Krok 3: Umístěte první panelovou stěnu na zadní část kůlny, dle vytištěných sériových čísel (**část 7699**).

Krok 29: Na spojení obou hliníkových profilů (nákres b) prosím použijte silikonové těsnění (tmel), aby se zabránilo prosakování vody.

Krok 39: Dejte pozor, aby panely a profily byl propojeny správným směrem a otvory profilů byly správně umístěny tak, jak je to zobrazeno na obrázku.

Krok 46: Ukotvěte kůlnu k pevnému povrchu, jako je beton či asfalt, použijte vhodné šrouby a hmoždinky. (Šrouby a hmoždinky nejsou součástí produktu).

*Vezměte prosím na vědomí: Ukotvení tohoto produktu k zemi je nezbytné pro jeho stabilitu a pevnost. Aby byla vaše záruka platná, je nutné dokončit tento krok.

Neutahujte šrouby a matky, (411 & 412) dokud kůlnu zcela nesestavíte. Tyto 2 ikony ukazují, zda je vyžadováno utážení šroubů či nikoliv.

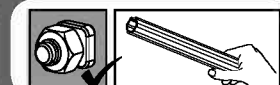
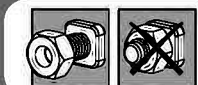

412



411



TÄRKEÄÄ

Lue nämä ohjeet huolellisesti, ennen kuin aloitat vajan kokoonpanon. Suorita vaiheet järjestyksellisesti esitettyjen ohjeiden mukaan. Säilytä nämä ohjeet varmassa paikassa myöhempää käyttöä varten.

Tarvitset

T001 - (sisällettyinä)

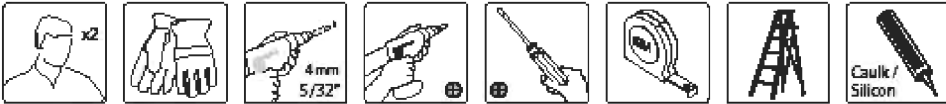

(nämä eivät ole sisällettyinä toimitukseen)

Turvallisuus

- Tämä vaja on sijoitettava ja kiinnitettävä tasaiselle pinnalle turvaamaan vakautensa.
- Varmista, että ruuvit ja ankkurit sopivat pintatyyppiin.
- Joillakin osilla on metalliset reunat. Ole varovainen, kun käsittelet komponentteja.
- Käytä aina suojakäsineitä, suojalaseja ja pitkiä hihoja asennuksen ja huoltotoimenpiteiden aikana vajassa.
- Älä yritä panna kokoon vajaa päivinä jolloin tuulee voimakkaasti tai alhaisissa lämpötiloissa. Jos käytät tikkaita tai sähkötyökaluja varmista, että noudatat valmistajan turvallisuusohjeita.
- Älä seiso katolla.
- Älä säilytä vajassa kuumia esineitä, kuten äsken käytettyä grilliä, puhalluslampua jne.
- Älä nojaa raskaita tai teräviä esineitä seinäpaneelija vastaan.
- Älä anna lasten leikkiä pakkausmateriaalien kanssa estääksesi tukehtumisen vaaran.

Ennen kuin aloitat

- Kysy neuvoa paikallisilta viranomaisilta rakennusrajoituksista ja myös tarvitaanko lupaa puutarhakatoksen rakentamiseksi.
- Vaja on sijoitettava ja kiinnitettävä tasaiselle alustalle.
- Suorita loppuun alueen valistelu ennen osien purkaamista ja ennenkuin aloitat kokoonpanoa.
- On erittäin suositeltavaa että toinen henkilö avustaisi joissakin vaiheissa.
- Lajittele osat ja vertaa sisältö osaluetteloon.
- Seuraa turvaohjeita asennuksen aikana.

Kokoonpanon aikana

Kohdattaessasi tietokuvakkeen, katso asiankuuluvaa kokoonpanovaihetta lisäkommentteja ja apua varten.



Tämä kuvake osoittaa, että asentaja pitäisi olla tuotteen ulkopuolella



Tämä kuvake osoittaa että asentajan pitäisi olla tuotteen sisällä

**Huomio:**

- On tärkeää porata ruuvit paneeliharjun yläosassa ja varmistaa, että ruuvit tunkeutuvat levyn läpi maksimaalisen kestävyuden saamiseksi.
- Varmista, että paneelin alaharja on sijoitettu kohti vajan lattiaa ja että se sulkee sen sisään.

Vaihe 3: Aseta ensimmäisen seinälevyn vajan takaosaan leimatun sarjanumeron (osa 7699) mukaan.

Vaihe 29: Lisää silikonitiivistettä alumiinikappaleiden (piirros b) liitoksen väliin, estääksesi veden tiikkumisen sisään.

Vaihe 39: Ota huomioon, että paneelit ja profiilit ovat kytkettyjä oikeaan suuntaan sekä että profiilien reijät ovat asetettu oikein kuvan mukaisesti.

Vaihe 46: Ankkuroi suoja kiinteään pintaan, kuten betoni tai asfaltti, sopivilla ruuveilla ja tulvilla. (Ruuvit ja tulpat eivät sisälly toimitukseen).

*Huomaa: tuotteen ankkurointi maahan on välttämätöntä sen vakauden ja jäykkyyden kannalta. Se vaaditaan tässä vaiheessa, jotta takuu olisi voimassa.

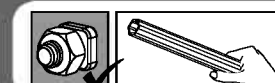
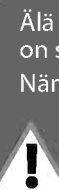

412



411



DÔLEŽITÉ

Pred začiatkom montáže tohto prístrešku si, prosím, dôkladne prečítajte pokyny. Kroky vykonajte v poradí uvedenom v týchto pokynoch. Tieto pokyny si ponechajte na bezpečnom mieste pre prípad potreby ich použitia v budúcnosti.

Budete potrebovať

T001 - (nástroje)

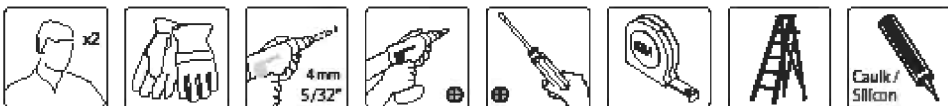

(tieto predmety nie sú súčasťou dodania)

Bezpečnosť

- Tento prístrešok musí byť umiestnený a upevnený na zarovnanom povrchu, aby sa zabezpečila jeho stabilita.
- Ubezpečte sa, že skrutky a kotvy sú kompatibilné s typom povrchu.
- Niektoré súčiastky majú kovové hrany. Pri zaobchádzaní s týmito súčiastkami buďte, prosím, opatrní.
- Pri montáži alebo vykonávaní údržby prístrešku vždy používajte rukavice, ochranu zraku a dlhé rukávy.
- O montáž sa nepokúšajte počas dní, keď je veterno alebo chladno. Ak používate dvojité rebríky alebo elektrické nástroje, zabezpečte sa, že nasledujete bezpečnostné pokyny výrobcu.
- Nestavajte sa na strechu.
- V prístrešku neskladujte horúce predmety, ako napríklad nedávno použité grily, opaľovacie lampy a podobne.
- O stenové panely nesmiete opierať ťažké alebo ostré predmety.
- Nedovoľte deťom hrať sa s baliacimi materiálmi, aby ste zabránili ich uduseniu.

Než začnete

- Informujte sa u miestnych úradov o akýchkoľvek obmedzeniach výstavby alebo stavebných povoleniach potrebných na výstavbu tohto záhradného prístrešku.
- Prístrešok musí byť umiestnený a upevnený na zarovnaný povrch.
- Pred odbalením súčastí a začiatkom montáže dokončite prípravu miesta na stavbu.
- Pri niektorých krokoch sa silno odporúča pomoc druhej osoby.
- Zoradte súčiastky a skontrolujte, či máte všetky pomocou ich zoznamu.

Počas montáže

Keď narazíte na informačnú ikonu, riadte sa náležitým krokom montáže, kde nájdete ďalšie komentáre a rady.



Táto ikona označuje, že montér sa má nachádzať vo vnútri výrobku.



Táto ikona označuje, že montér sa má nachádzať mimo výrobku.

**Pozor:**

- Je dôležité navrtať skrutky na vrch chrbta panela a ubezpečiť sa, že skrutky panelom prenikajú, aby sa zabezpečila maximálna výdrž.
- Ubezpečte sa, že umiestnite spodok chrbta panela smerom k podlahe prístrešku, a že ju ohraničuje.

Krok 3: Umiestnite prvý stenový panel na zadnú časť prístrešku podľa vyrazeného sériového čísla (**časť 7699**).

Krok 29: Prosím, aplikujte tesniaci silikón na prípojku medzi oboma hliníkovými profilmi (nákres b), aby sa predišlo presiaknutiu vody.

Krok 39: Upozorňujeme, že je potrebné panely a profily spojiť v správnom smere a tiež, že otvory profilu je potrebné umiestniť správne, ako je to znázornené na obrázku.

Krok 46: ukotvíte prístrešky na pevnom povrchu, ako je betón či asfalt, použite vhodné skrutky a hmoždinky. (Skrutky a hmoždinky nie sú súčasťou dodávky).

* Vezmite, prosím, na vedomie: Ukotvenie tohto výrobku na zem, je potrebné pre jeho stabilitu a tuhosť. Vyžaduje sa na dokončenie tejto fázy, aby platila záruka.

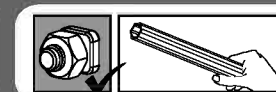
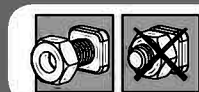

412



411



Nedoťahujte skrutky a matice (411 a 412) až do dokončenia procesu montáže. Tieto 2 ikony označujú, či je potrebné skrutky dotiahnuť alebo nie

ВАЖНО!

Внимательно прочитайте эту инструкцию перед началом сборки этого изделия. Выполняйте шаги в порядке, установленном настоящей инструкцией. Сохраните эту инструкцию в надежном месте для дальнейшего использования.

Инструменты и оборудование

T001 - (прилагается)



(эти предметы не поставляется)

Безопасность

- ✓ Это сарай должен следует размещать и закреплять на ровной поверхности, чтобы обеспечить его устойчивость. Убедитесь, что винты и крепления соответствуют типу поверхности.
- ✓ Некоторые части имеют металлические края. Будьте осторожны при обращении с этими компонентами.
- ✓ Всегда надевайте защитные перчатки, защитные очки и одежду с длинными рукавами при сборке или выполнении техобслуживания вашего сарая.
- ✓ Не пытайтесь выполнять сборку в дни с сильными ветрами или низкими температурами. При использовании стремянки или электроинструментов выполняйте указания по технике безопасности их производителей.
- ✓ Не стойте на крыше.
- ✓ Не храните в сарае горячие предметы, такие как недавно использованные грили, паяльные лампы и т.д.
- ✓ К стеновым панелям не следует прислонять тяжелые или острые предметы.
- ✓ Для предотвращения удушья не позволяйте детям играть с упаковочными материалами.
- ✓ Сарай следует закрепить, просверлив панели пола в местах для отверстий и закрутив подходящие винты в землю.

До начала сборки

- ✓ Уточните у ваших местных властей имеются ли какие-либо ограничения и необходимо ли получать какие-либо разрешения для постройки садового сарая.
- ✓ Подготовьте место установки до распаковки частей и начало сборки.

- ✓ На некоторых этапах настоятельно рекомендуется воспользоваться помощью другого человека.
- ✓ Отсортируйте детали и проверьте их наличие по списку частей в упаковке.
- ✓ Во время сборки примите меры предосторожности.

Во время сборки

Если во время сборки вы увидите значок информации, ознакомьтесь с описанием соответствующего шага сборки. В нем будут приведены дополнительные комментарии, которые помогут вам.



Этот значок означает, что выполняющему сборку лицу нужно находиться внутри изделия.



Этот значок означает, что выполняющему сборку лицу нужно находиться снаружи изделия.

**Внимание:**

- ✓ Важно просверлить винтами верхнюю часть гребня панели, чтобы убедиться в проникновении винтов через панель. Это позволит обеспечить максимальную прочность.
- ✓ Убедитесь, что нижний гребень панели ориентирован в сторону пола сарая и окружает его.

- **Шаг 3:** Установите первую стеновую панель в задней части сарая согласно со проштампованным серийным номером (**часть №7699**).
- **Шаг 29:** Нанесите силиконовый герметик (замазку) на соединение двух алюминиевых профилей (**схема «б»**), чтобы вода не просачивалась внутрь.
- **Шаг 39:** Убедитесь, что панель и профили соединены в нужном направлении, а также в том, что отверстия профилей расположены правильно, как показано.
- **Шаг 46:** Закрепите сарай на твердой поверхности, например, на бетоне или асфальте, и используйте для этого подходящие винты и пробки. (Винты и пробки не входят в комплект).
- **Обратите внимание!** Крепление этого изделия к земле имеет важное значение для его устойчивости и жесткости. Этот этап требуется выполнить для обеспечения действительности вашей гарантии.

Не затягивайте винты и гайки (**411 и 412**) до завершения процесса сборки. Эти 2 значка показывают, нужна ли затяжка винтов или нет.

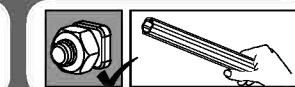

IMPORTANT

Vă rugăm să citiți aceste instrucțiuni cu atenție, înainte de a începe să asamblați acest produs. Vă rugăm să urmați pașii în ordinea stabilită în aceste instrucțiuni. Vă rugăm să păstrați aceste instrucțiuni într-un loc sigur, pentru consultare ulterioară.

Siguranță

- ✓ Această baracă trebuie să fie plasată și fixată pe o suprafață netedă, pentru a-i asigura stabilitatea. Asigurați-vă că șuruburile și elementele de ancorare sunt compatibile cu tipul suprafeței.
- ✓ Unele piese au margini metalice. Vă rugăm să fiți atenți când manevrați componentele.
- ✓ Purtați întotdeauna mănuși, ochelari de protecție și mâneci lungi, atunci când efectuați asamblarea sau când efectuați orice tip de lucrare de întreținere a produsului dvs.
- ✓ Nu încercați să asamblați baraca în zile cu vânturi puternice sau cu temperaturi scăzute. În cazul în care utilizați o scară mobilă sau unelte electrice, asigurați-vă că respectați întocmai sfaturile privind siguranța furnizate de producător.
- ✓ Nu stați pe acoperiș.
- ✓ Nu depozitați în baracă articole fierbinți, precum grătare care tocmai au fost utilizate, lămpi de lipit, etc.
- ✓ Nu sprijiniți de panourile pereților articole grele sau ascuțite.
- ✓ Pentru a împiedica sufocarea, nu permiteți copiilor să se joace cu materialele ambalajului.
- ✓ Baraca trebuie să fie fixată dând găuri prin locașurile din panourile podelei și introducând în sol șuruburile adecvate.

Înainte de a începe

- ✓ Consultați autoritățile locale pentru a afla dacă există limitări privind construcțiile sau permise de construcție necesare pentru a instala această baracă.
- ✓ Efectuați pregătirea locului înainte de a despacheta piesele și a începe asamblarea.
- ✓ Se recomandă să fiți asistat de încă o persoană la executarea unora dintre pași.
- ✓ Sortați piesele și verificați-le prin comparație cu lista componentelor.
- ✓ Vă rugăm să luați măsuri de precauție în cursul asamblării.

Unelte și echipamente

T001 - (unelte)

(aceste articole nu sunt furnizate)

**În cursul asamblării**

Atunci când apare pictograma informațiilor, vă rugăm să consultați pasul de asamblare corespunzător, pentru comentarii și asistență suplimentară.



Această pictogramă indică faptul că persoana care efectuează instalarea trebuie să se afle în interiorul produsului



Această pictogramă indică faptul că persoana care efectuează instalarea trebuie să se afle în afara produsului

**Atenție:**

- ✓ Este important să introduceți șuruburile în partea superioară a marginii panoului și să vă asigurați că șuruburile trec prin panou, pentru a beneficia de durabilitate maximă.
- ✓ Asigurați-vă că poziționați marginea din partea de jos a panoului spre podeaua barăcii și că o include.

Pasul 3: Plasați panoul primului perete în spatele barăcii, conform numărului de serie ștanțat (**piesa 7699**).

Pasul 29: Vă rugăm aplicați material de etanșare din silicon (calafat) la legăturile dintre ambele profiluri din aluminiu (diagrama b), pentru a preveni infiltrarea apei.

Pasul 39: Vă rugăm să rețineți că panoul și profilurile trebuie să fie conectate în direcția corectă, iar găurile profilelor să fie plasate corect, așa cum este ilustrat.

Pasul 46: Ancorați baraca pe o suprafață solidă, pe beton sau asfalt, și utilizați șuruburi și știfturi. (Șuruburile și știfturile nu sunt incluse).

***Vă rugăm să rețineți:** Ancorarea acestui produs de sol este esențială pentru stabilitatea și rigiditatea lui. Este necesar să duceți la bun sfârșit acest pas pentru ca garanția dvs. să fie valabilă.

Nu strângeți șuruburile și piulițele (411 și 412) până la finalizarea procesului de asamblare. Aceste 2 pictograme arată dacă strângerea șuruburilor este necesară sau nu.

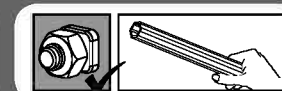

412



411



IMPORTANTE

Por favor leia estas instruções antes de começar a montar este estábulo.
Por favor seguir os passos pela ordem configurada nestas instruções.
Mantenha estas instruções num lugar seguro para futura referência.

Ferramentas

T001 - (supplied)

(estes itens não são fornecidos)

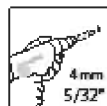
**Segurança**

- ✓ Este estábulo deverá ser colocado e montado numa superfície nivelada por forma a assegurar a sua estabilidade.
- ✓ Certifique-se que os parafusos e âncoras são compatíveis com o tipo de superfície. Algumas partes têm arestas de metal. Por favor tenha cuidado no manuseamento destas componentes.
- ✓ Usar sempre luvas, protetores oculares e mangas compridas enquanto monta e desempenha alguma manutenção no estábulo.
- ✓ Não tente montar em dias com forte vento ou temperaturas baixas. Se estiver a usar um escadote ou ferramentas energética certifique-se que está a seguir os conselhos de segurança do fabricante.
- ✓ Não esteja no telhado.
- ✓ Não armazene itens quentes como por exemplo grelhas recentemente usadas, maçaricos, etc. no estábulo.
- ✓ Artigos pesados ou afiados não deverão ser debruçados contra os painéis da parede.
- ✓ Para prevenir asfixia não permitir que as crianças brinquem com materiais empacotado.
- ✓ O estábulo deverá ser seguro por perfuração através de painéis do chão em locais de furos e inserindo parafusos adequados

Antes de começar

- ✓ Consulte as suas autoridades locais para quaisquer limites ou permissões de construção requeridas par a construção deste galpão de jardim.
- ✓ Complete a preparação da obra antes de começar a desembalar partes e iniciar a montagem.
- ✓ É altamente recomendável a assistência de uma segunda pessoa para alguns passos.
- ✓ Escolha as partes e verifique em conformidade com a lista de partes nela constantes.
- ✓ Por favor tome precauções de segurança durante a montagem.

Durante a montagem

Quando encontrar com o ícone de informação por favor tome por referência o passo relevante de montagem para comentários e assistência adicionais.



Este ícone indica que o instalador deverá estar dentro do produto



Este ícone indica que o instalador deverá estar fora do produto

**Atenção:**

- ✓ É importante aparafusar os parafusos no topo do rebordo do painel e certificar-se que os parafusos penetram o painel por forma a ter a máxima durabilidade.
- ✓ Certifique-se que posiciona o botão do painel de rebordo em direção ao chão do estábulo e que isso o está a delimitá-lo.

Passo 3: Coloca o primeiro painel de parede nas traseiras do estábulo de acordo com o número de série timbrado (**parte 7699**).

Passo 29: Por favor, aplique silicone (de calafetar) vedante na ligação entre os perfis de Alumínio (diagrama b), para evitar que a água penetre.

Passo 39: Certifique-se que o painel e perfis estão conectados na direção certa e se os furos dos perfis estão colocados corretamente conforme ilustrado.

Passo 46: Ancorar o estábulo numa superfície sólida tal como cimento ou asfalto, usar parafusos e tomadas adequadas. (Parafusos e tomadas não são fornecidas).

***Por favor note que:** Ancorar este produto ao chão é essencial para a sua estabilidade e rigidez e é requerido completar esta fase por forma a ter a sua garantia válida.

Não aperte parafusos ou porcas (411 & 412) até completar o processo de montagem. Estes 2 ícones indicam se o aperto dos parafusos é requerido ou não

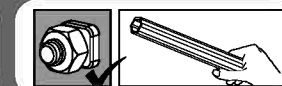

412



411



WAŻNE

Proszę uważnie przeczytać instrukcję przed rozpoczęciem montażu domku ogrodowego. Proszę wykonać wszystkie etapy w kolejności przedstawionej w instrukcji. Instrukcję należy zachować w bezpiecznym miejscu w celu wykorzystania jej w przyszłości.

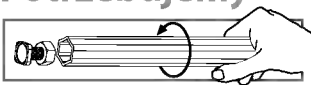
Potrzebujemy

T001 - (w zestawie)



(Zestaw tego nie obejmuje)

Uwagi dotyczące bezpieczeństwa

- ✓ Domek należy umieścić i zamocować na wypoziomowanym podłożu, aby zapewnić jego stabilność. Należy upewnić się, że śruby i kotwy są odpowiednie do rodzaju podłoża.
- ✓ Niektóre części mają metalowe krawędzie. Proszę o ostrożne trzymanie części domku ogrodowego.
- ✓ Należy zawsze używać rękawiczek, okularów ochronnych i długich rękawów w trakcie montażu i wykonywania jakichkolwiek czynności konserwacyjnych przy domku ogrodowym.
- ✓ Nie należy montować domku ogrodowego, gdy jest bardzo wietrznie albo gdy jest niska temperatura. Podczas korzystania z drabiny i narzędzi z napędem elektrycznym należy zastosować się do zaleceń producenta.
- ✓ Nie wolno stać na dachu.
- ✓ Nie należy przechowywać gorących przedmiotów, na przykład niedawno używanych grillów, lamp lutowniczych itp. w domku.
- ✓ Nie należy opierać ciężkich ani ostrych rzeczy o panele ścienne.
- ✓ Aby uniknąć uduszenia, nie należy pozwalać dzieciom na zabawę opakowaniami.
- ✓ Domek ogrodowy należy przymocować poprzez wywiercenie otworów przez panele podłogowe i wkręcenie odpowiednich śrub w ziemię.

Zanim przystąpimy do montażu

- ✓ Proszę sprawdzić, czy postawienie domku ogrodowego nie wymaga odpowiedniego zezwolenia z urzędu.
- ✓ Należy przygotować teren pod budowę zanim rozpakujemy części domku ogrodowego i zaczniemy montaż.
- ✓ Doradzamy, aby na niektórych etapach domek ogrodowy budowały co najmniej dwie osoby.
- ✓ Należy posortować wszystkie części i sprawdzić je z listą zawartości.
- ✓ Należy zachować środki ostrożności podczas montażu.

Podczas montażu

Gdy widzimy ikonkę informacyjną, należy zwrócić uwagę na odpowiedni etap montażu, aby uzyskać dodatkowe wskazówki i pomoc.



Ta ikonka informuje, iż osoba montująca powinna znajdować się w środku domku.



Ta ikonka informuje, iż osoba montująca powinna znajdować się na zewnątrz domku.

**Uwaga:**

- ✓ Ważne jest, aby wkręcić śruby na górze grzbietu panelu i upewnić się, że śruby przechodzą przez panel aby uzyskać maksymalną wytrzymałość.
- ✓ Upewnij się, że dolny grzbiet panelu znajduje się w kierunku podłogi domku i zamyka ją.

Etap 3: Umieść Pierwszy panel ścienny na panelu podstawy domku ogrodowego zgodnie z ostemplowanym numerem seryjnym (**część 7699**).

Etap 29: Proszę zastosować uszczelniać silikonowego (uszczelniając na połączenia między obu profili aluminiowych (schemat B), w celu uniknięcia wody sączącej się.

Etap 39: Zwróć uwagę jak panele i profile są połączone w odpowiednim kierunku oraz otwory w profilach umieszczone są poprawnie, jak na rysunku.

Etap 46: Proszę pamiętać, że przymocowanie tego produktu do ziemi jest kluczowe dla jego stabilności i sztywności.

* Aby Państwa gwarancja zachowała ważność, wymagane jest wykonanie tego etapu.

Nie należy dokręcać śrub i nakrętek (411 i 412) aż do zakończenia montażu. Te dwie ikonki informują, czy śruby wymagają dokręcenia czy nie.

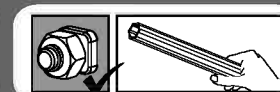

412



411



VIKTIG

Les disse instruksjonene nøye før du begynner å montere skuret.
Utfør alle trinnene i rekkefølgen som er fastsatt i instruksjonene.
Oppbevar disse instruksjonene på et trygt sted for framtidig referanse.

Verktøy og utstyr



T001 - (følger med)

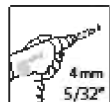

(disse elementene følger ikke med)

Sikkerhet

- Dette skuret må plasseres og festes på en jevn overflate for å sikre god stabilitet.
- Pass på at skruer og ankere passer til overflatetypen.
- Noen deler har metallkanter. Vær forsiktig når du håndterer komponentene.
- Bruk alltid hansker, vernebriller og lange ermer når du monterer eller utfører vedlikehold på skuret.
- Ikke utfør monteringen om det er sterk vind eller lav temperatur. Hvis du bruker gardintrapp eller elektroverktøy, sørg for å følge produsentenes sikkerhetsanvisninger.
- Ikke stå på taket.
- Ikke oppbevar varme gjenstander som f.eks. nylig brukte griller, blåselamper e.l. i skuret.
- Tunge eller skarpe gjenstander må ikke støttes opp mot veggpanelet.
- Ikke la barn leke med emballasjen på grunn av kvelningsfare.
- Skuret må sikres ved å bore gjennom hullene i gulvpanelet og sette inn passende skruer i bakken.

Før du begynner

- Kontakt lokale myndigheter for å se om du trenger byggetillatelse for å sette opp dette hageskuret.
- Fullfør grunnarbeidet før du pakker ut delene og begynner monteringen.
- Det anbefales sterkt at du i noen trinn av monteringen får hjelp av en annen person.
- Sorter delene og sjekk dem opp mot delelisten.
- Ta nødvendige sikkerhetsforanstaltninger når du monterer.

Under montering



Når du ser informasjonsikonet, se det relevante monteringstrinnet for flere kommentarer og mer hjelp.



Dette symbolet indikerer at montøren skal befinne seg på utsiden.



Dette symbolet indikerer at montøren skal befinne seg på innsiden.



OBS!

- Det er viktig å bore skruene øverst på panelkanten og sørge for at skruene trenger gjennom panelet for å oppnå maksimal holdbarhet.
- Pass på å plassere den nedre kanten av panelet mot gulvet til skuret og at den omslutter bakken.

Trinn 3: Plasser den første veggplaten på baksiden av skuret i henhold til det stemplede serienummeret (**del 7699**).

Step 29: Please apply silicone (caulk) sealant at the connection between both Aluminum profiles (diagram b), in order to prevent water from seeping in.

Trinn 39: Påse at paneler og profiler kobles sammen i riktig retning, samt at profilhullene er riktig plassert, som vist på bildet.

Steg 46: Skuret bør sikres (forankres) i en solid overflate som betong eller asfalt; bruk passende skruer og pluggar. (Skruer og pluggar følger ikke med.)

*Vennligst bemerk: For å sikre produktets stabilitet er det essensielt å forankre produktet i bakken. Det er nødvendig å fullføre dette steget for at garantien skal være gyldig.

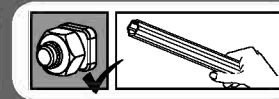
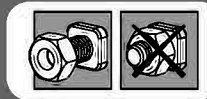

412



411



Ikke stram skruer og muttere (411 og 412) før du er ferdig med monteringsprosessen.
Disse to ikonene indikerer om det er nødvendig å stramme skruene.

VIKTIGT

Läs igenom dessa anvisningar noggrant innan du börjar montera boden.
Utför stegen i den ordningsföljd som anges i dessa anvisningar.
Behåll dessa anvisningar på ett säkert ställe för framtida bruk.

Verktyg

T001 - (supplied)

(dessa delar medföljer inte)

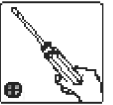
Caulk /
Silicon**Säkerhet**

- Denna bod måste placeras och fixeras på ett horisontellt underlag för att säkerställa dess stabilitet. Se till att skruvar och fästen är kompatibla med typen av yta.
- Några delar har metallkanter. Var försiktig när du hanterar komponenterna.
- Använd alltid handskar, ögonskydd och långa ärmar vid montering eller underhåll på din bod.
- Montera inte på dagar med stark vind eller låga temperaturer. Om du använder en trappstege eller eldrivna verktyg, se till att du följer tillverkarens säkerhetsanvisningar.
- Stå inte på taket.
- Förvara inte heta föremål såsom nyligen använda grillar, blåslampor etc. i boden.
- Tungga eller vassa föremål ska inte lutas mot väggpanelerna.
- För att förhindra kvävning, tillåt inte barn att leka med förpackningsmaterialet.

Innan du börjar

- Kontakta din lokala myndighet för eventuella byggnadsbegränsningar eller tillstånd, som krävs för att bygga denna trädgårdsbod.
- Bodens måste vara placerad och fastsatt på en plan yta.
- Genomför förberedelse av platsen för boden, innan du packar upp artiklar och startar montering.
- Det rekommenderas starkt att assisteras av en ytterligare person i vissa steg.
- Sortera artiklarna och kontrollera mot stycklistan.
- Vänligen vidta säkerhetsåtgärder under montering.

Under monteringen.

När man påträffar informationsikonen, se motsvarande monteringssteg för ytterligare kommentarer och hjälp



Denna ikon anger att installatören bör befinna sig inne i produkten.



Denna ikon anger att installatören bör befinna sig utanför produkten.

**Observera:**

- Det är viktigt att förborra för skruvarna överst på panelen kant och att se till att skruvarna tränger igenom panelen för att få maximal hållbarhet
- Se till att placera panelens nedre kant mot bodens golv och att den ansluter till det.

Steg 3: Placera den första väggpanelen på baksidan av boden enligt markerat serienummer (**del 7699**).

Steg 29: Please apply silicone (caulk) sealant at the connection between both Aluminum profiles (diagram b), in order to prevent water from seeping in.

Steg 39: Observera att paneler och profiler är kopplade i rätt riktning samt att profilhålen placerats korrekt som illustrerat.

Steg 46: Förankra skjutet på en solid yta såsom betong eller asfalt med hjälp av passande skruvar och pluggar. (Skruvar och pluggar medföljer ej).

***Observera:** Förankring av denna produkt på marken är nödvändigt för stabilitet och styvhet. Det är nödvändigt att slutföra det här steget för att din garanti ska gälla.

Dra inte åt skruvar och muttrar (411 & 412) förrän vid slutet av monteringsprocessen. Dessa 2 ikoner indikerar om skruvåtdragning är nödvändig eller ej

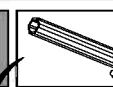





412





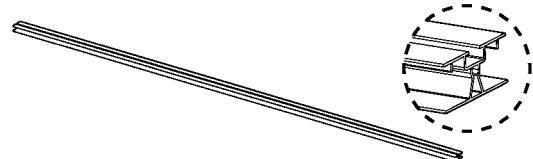
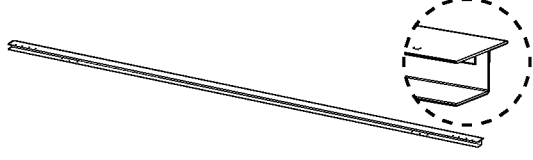
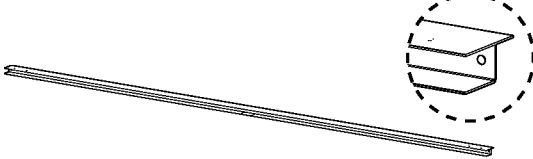

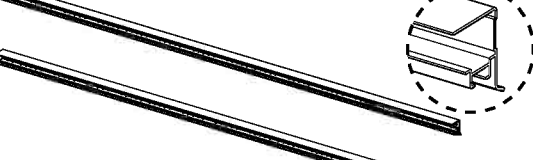

411

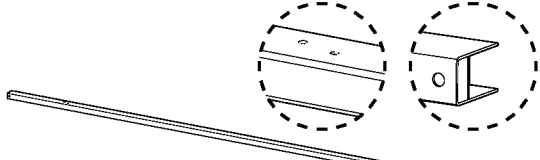
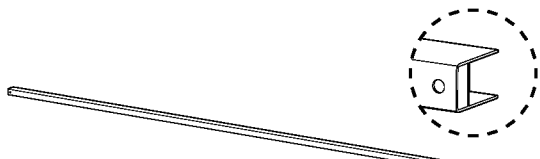
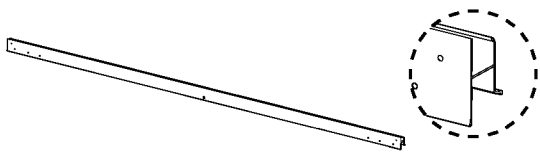
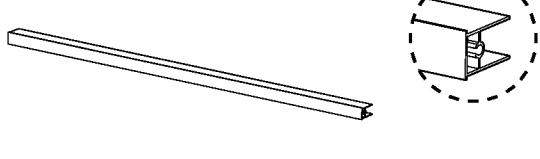
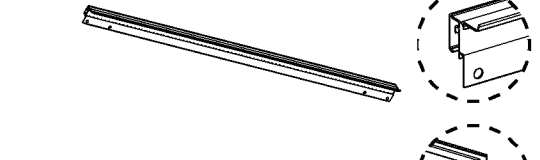

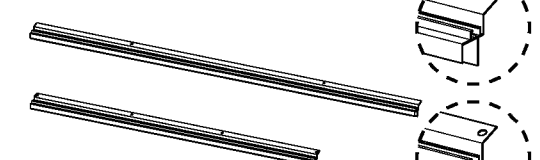



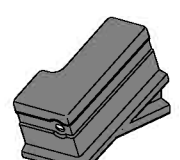
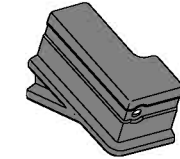
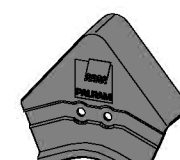
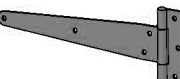
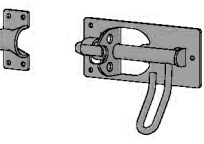
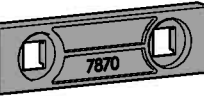
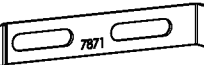





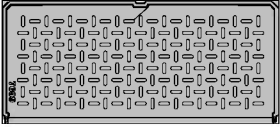
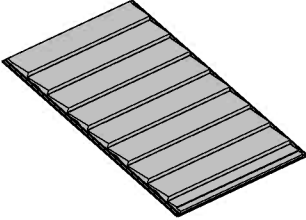

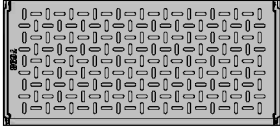

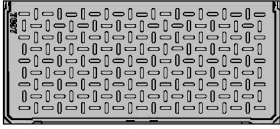
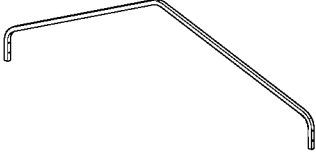
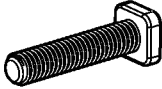

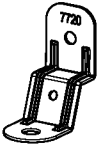

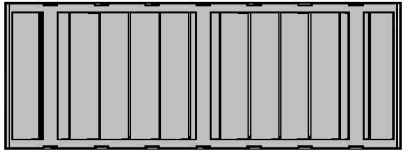
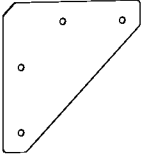

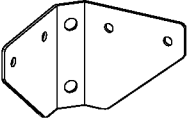
Contents

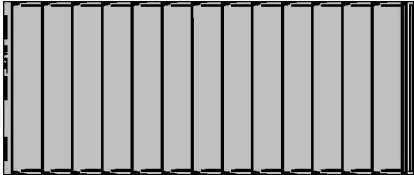
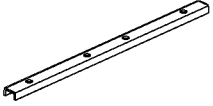
Item		Qty.
7733		4
7732		9
7725		2
7727		1
7965		8
8109		2
7970		2
7971		2

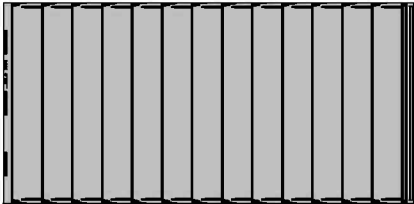
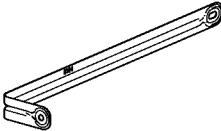
Item		Qty.
7381		2
7382		1
8012		2
7726		4
7967		4
8108		1
7961		2
8110		2
7976		4

Item		Qty.
7981		2
7980		2
7979		2
7356		4
7352		1
7870		2
7871		2
T001		1

Contents

Item		Qty.	Item		Qty.	Item		Qty.
7699		1	7982		10	411		105 (+10)
7698		3	7716		1	466		115 (+10)
7697		1	7718		2	7284		9 (+1)
8015		2	7720		13	7441		13 (+1)
7702		2	7400		2	7442		32 (+2)
7706		2	7986		4	7444		26 (+2)
7705		10	7985		12	7524		8 (+2)
7704		2	8104		2	4008 Black		8 (+2)
						4008 Silver		8 (+2)
						431		9 (+1)
						422		9 (+1)
						428		9 (+1)
						4020		2

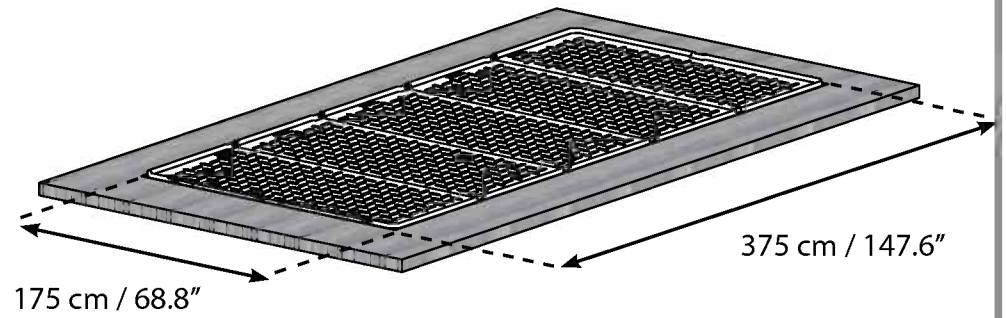
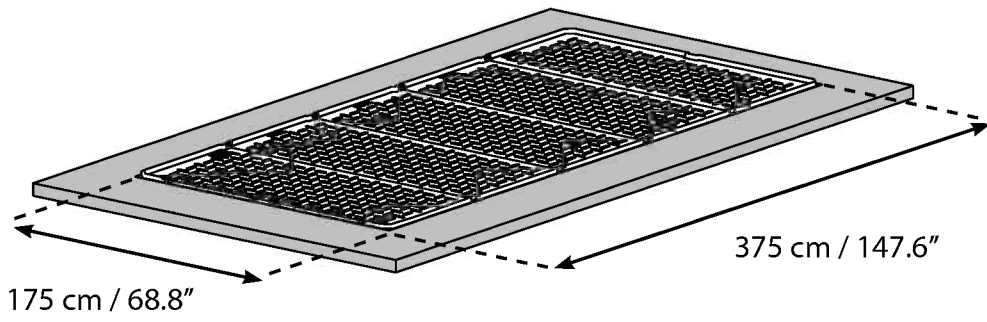

1

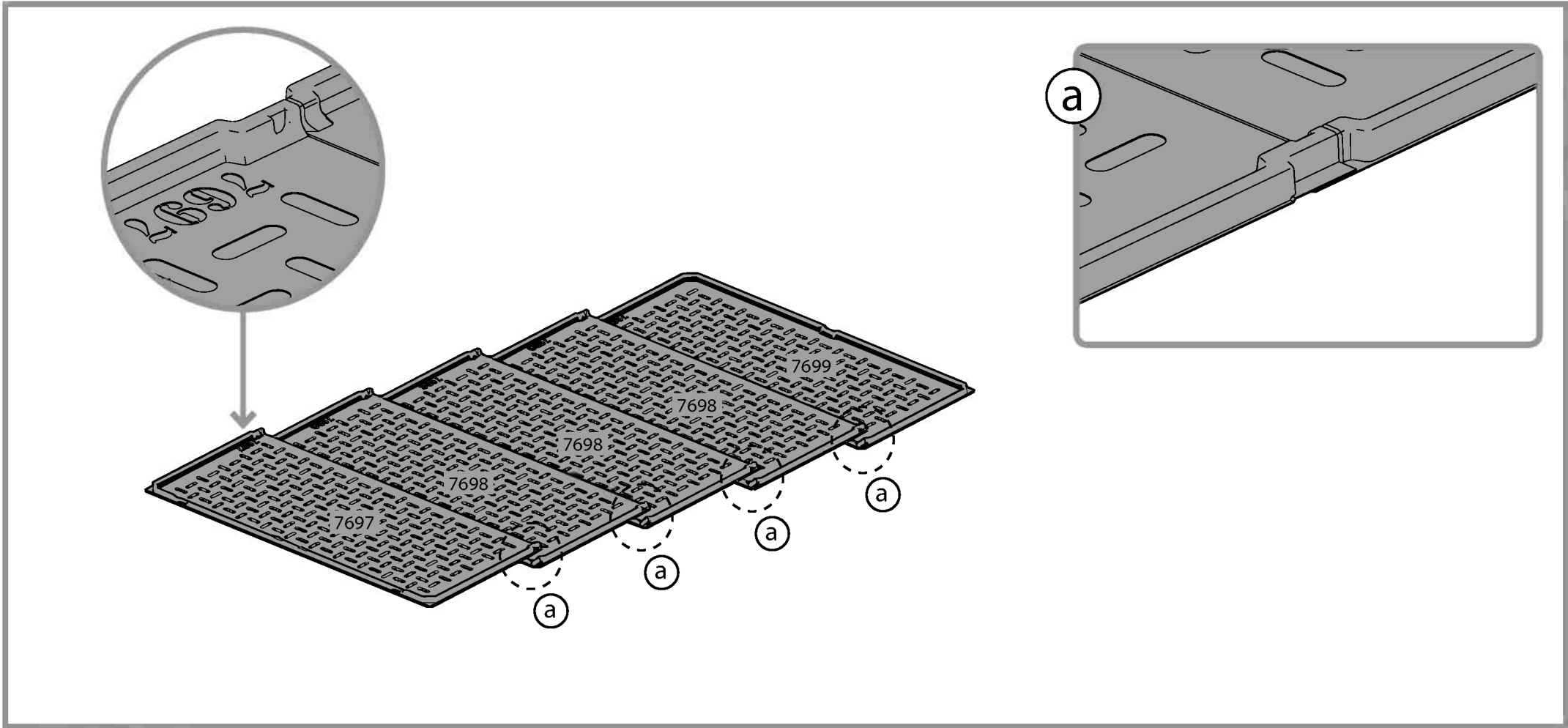
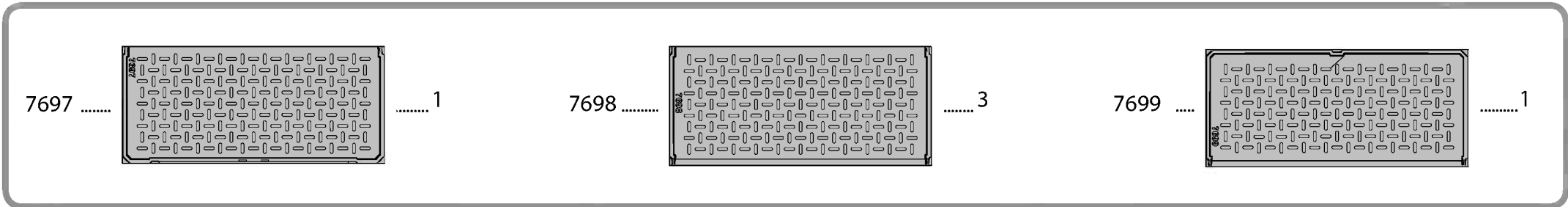

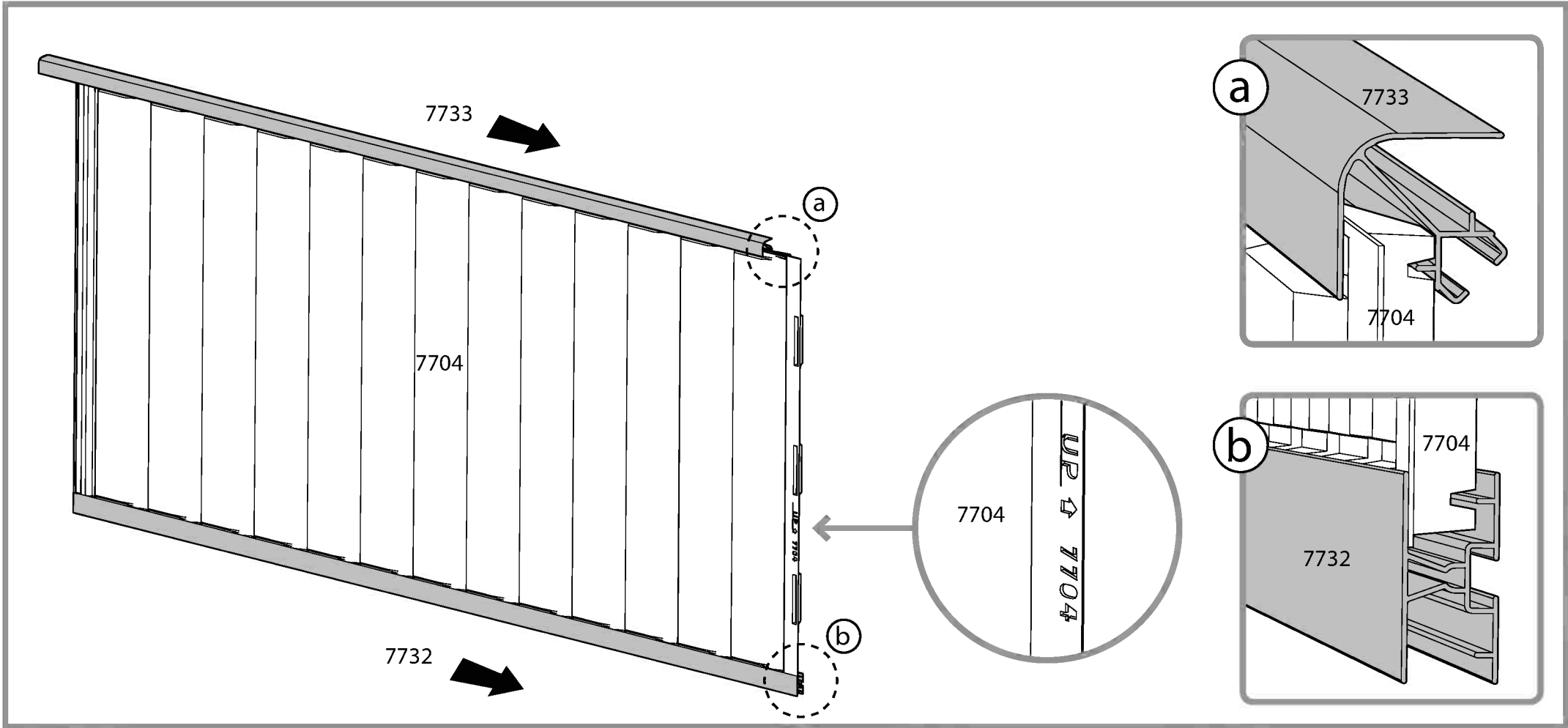
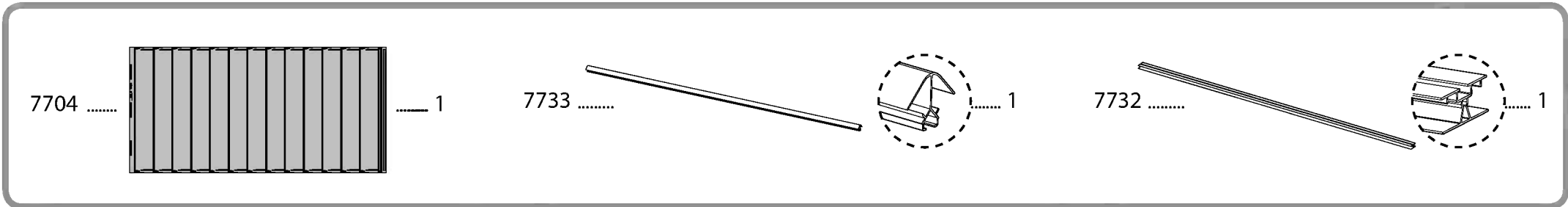
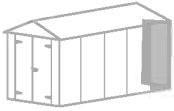

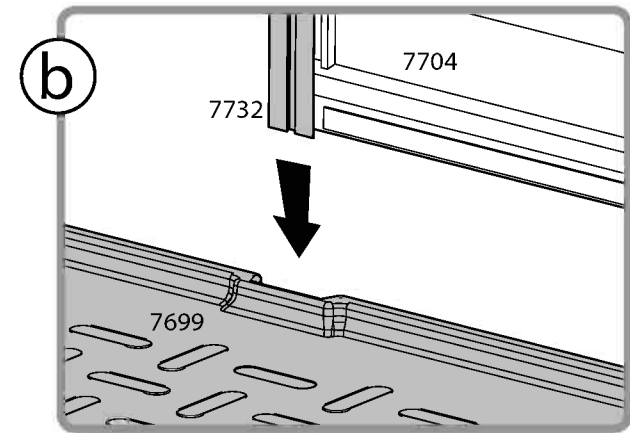
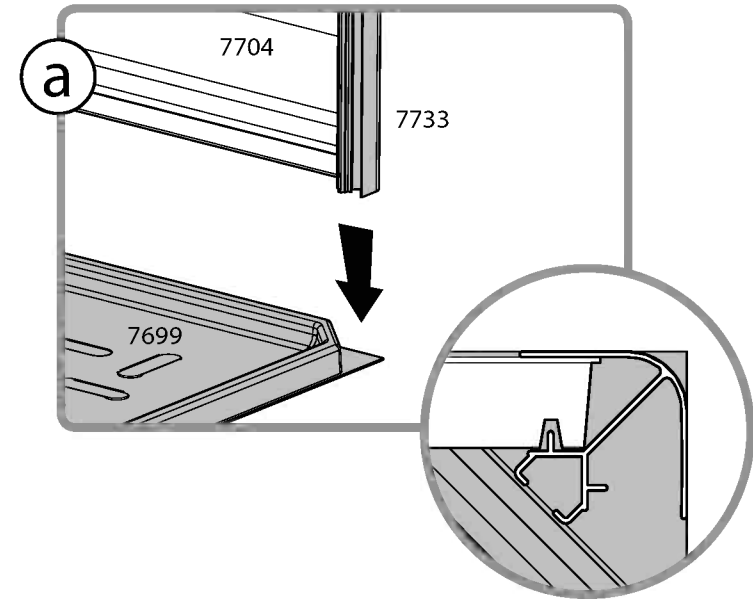
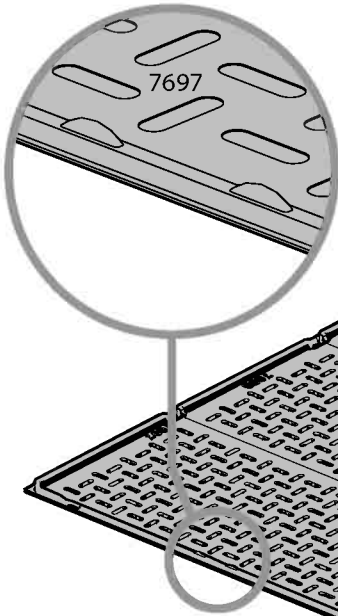
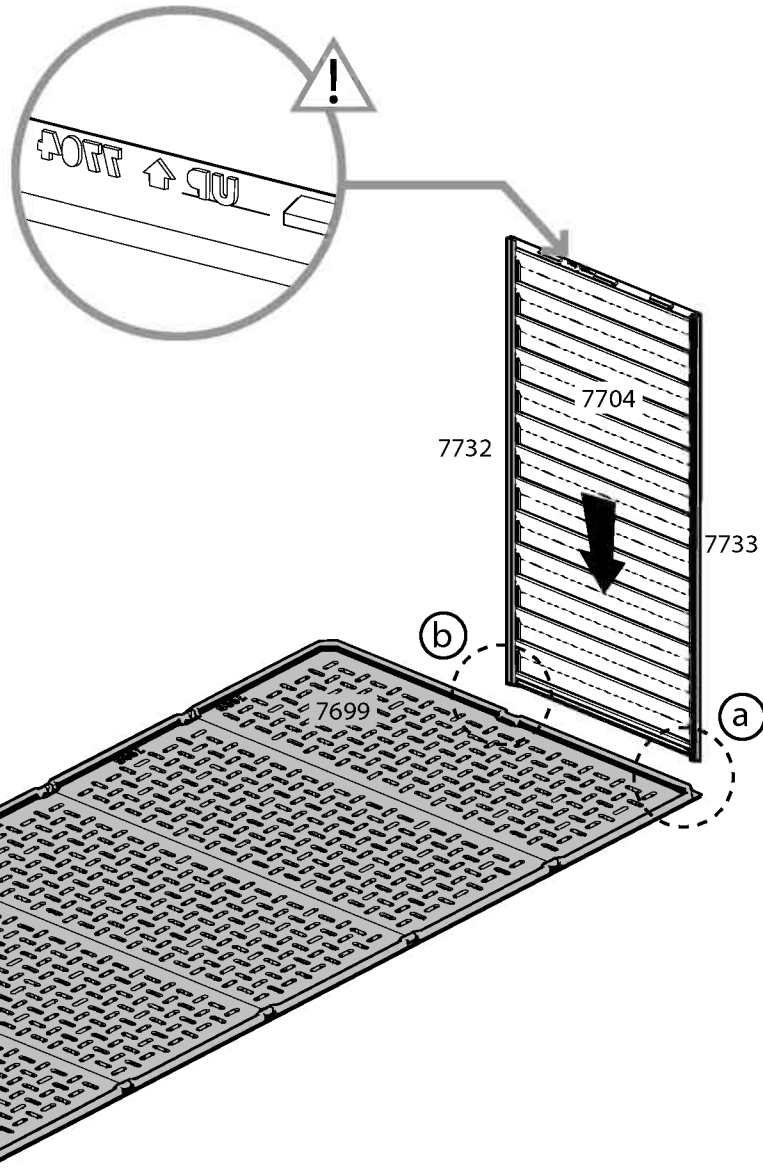





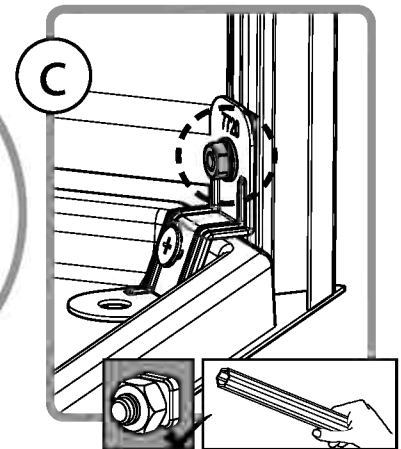
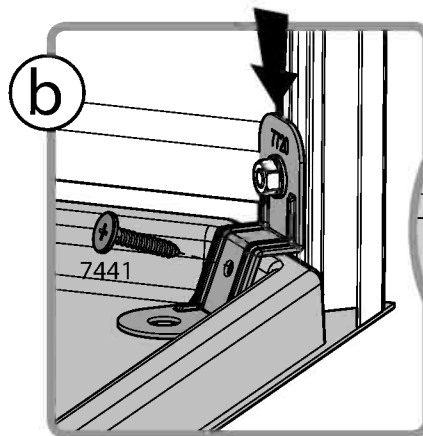
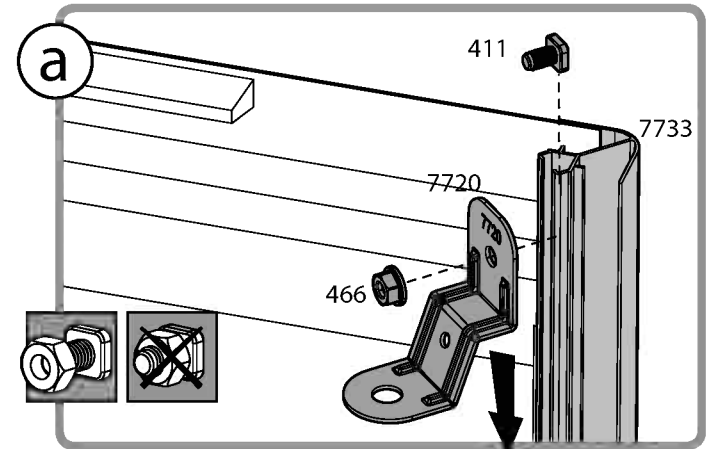
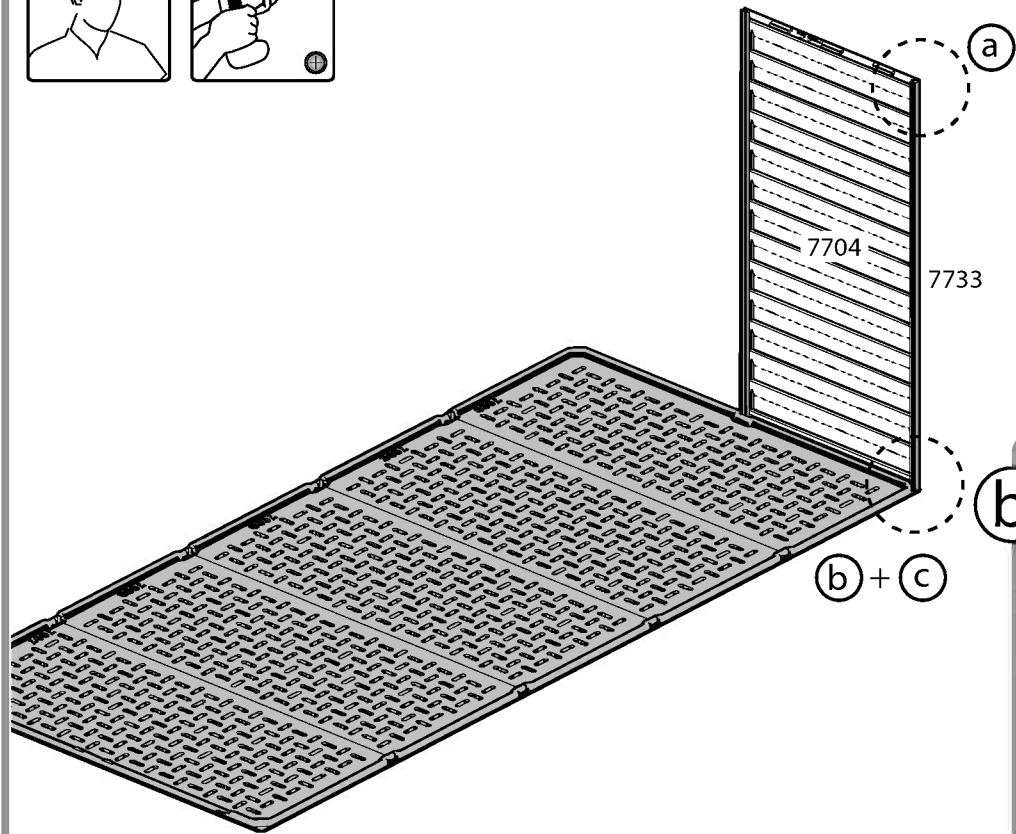
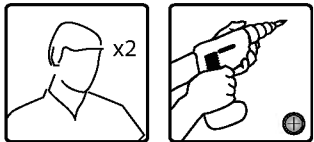

- 7720 1 411 1 466 1 7441..... 1
-

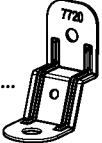



- 7720  1
- 411  1
- 466  1
- 7441.....  1

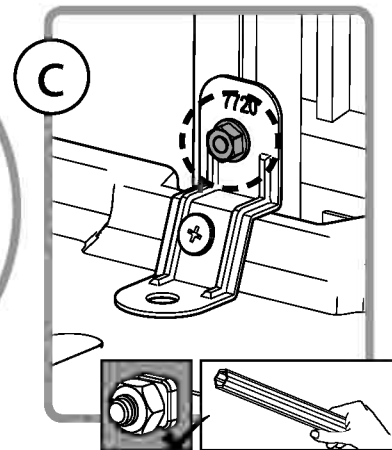
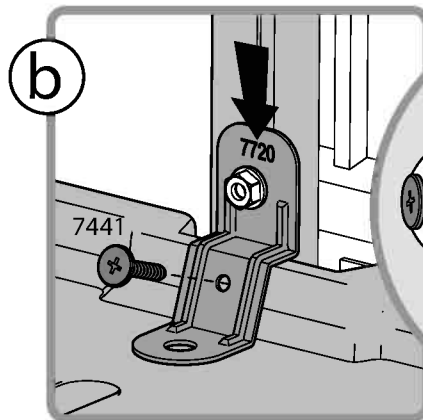
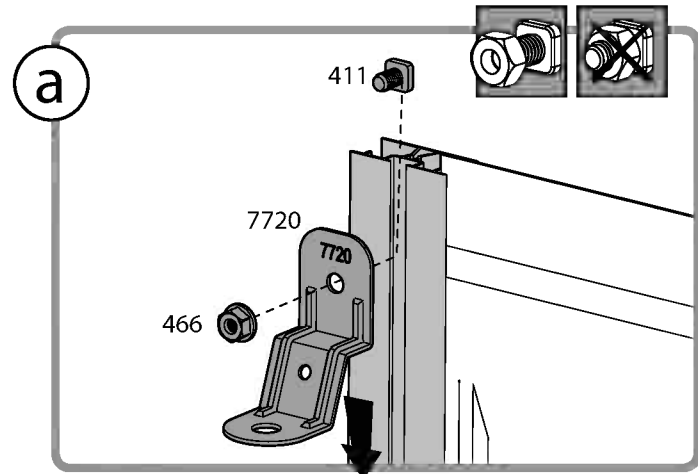
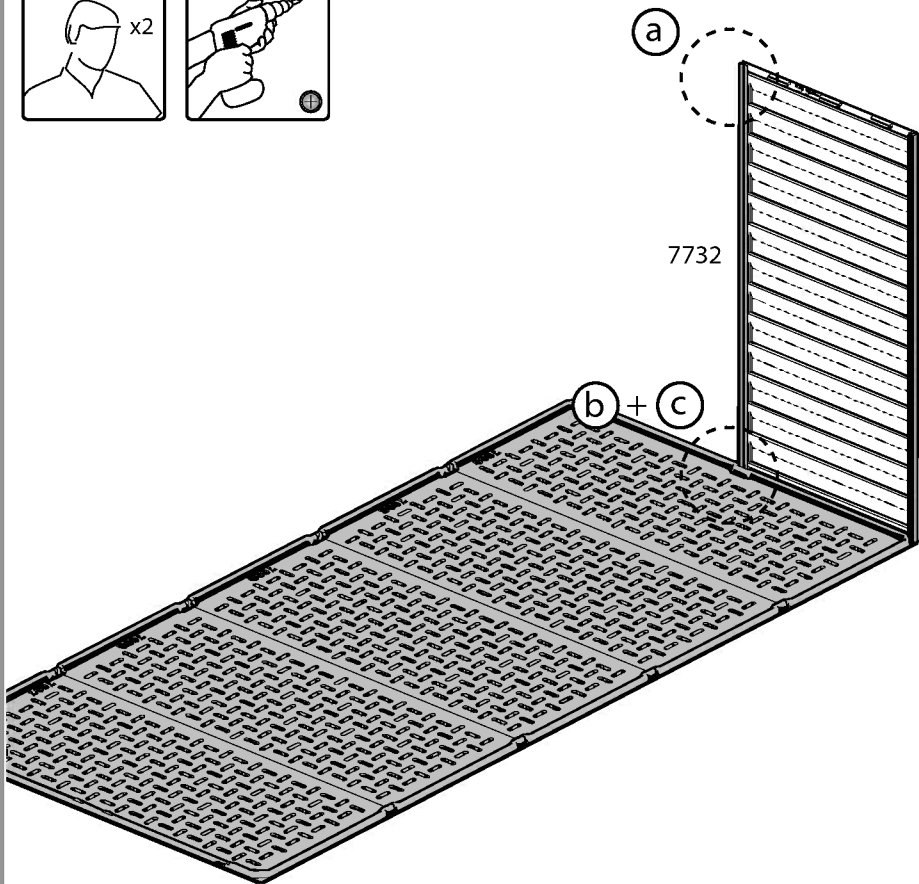
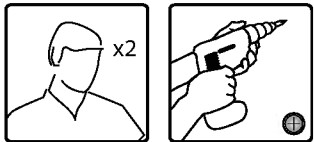

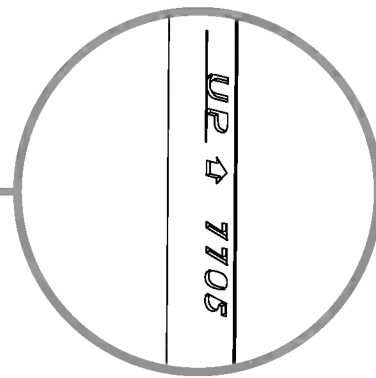
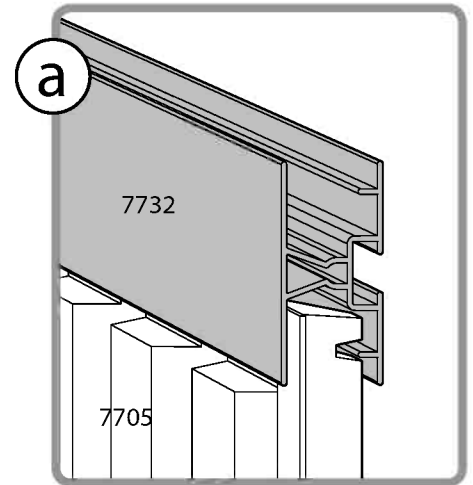
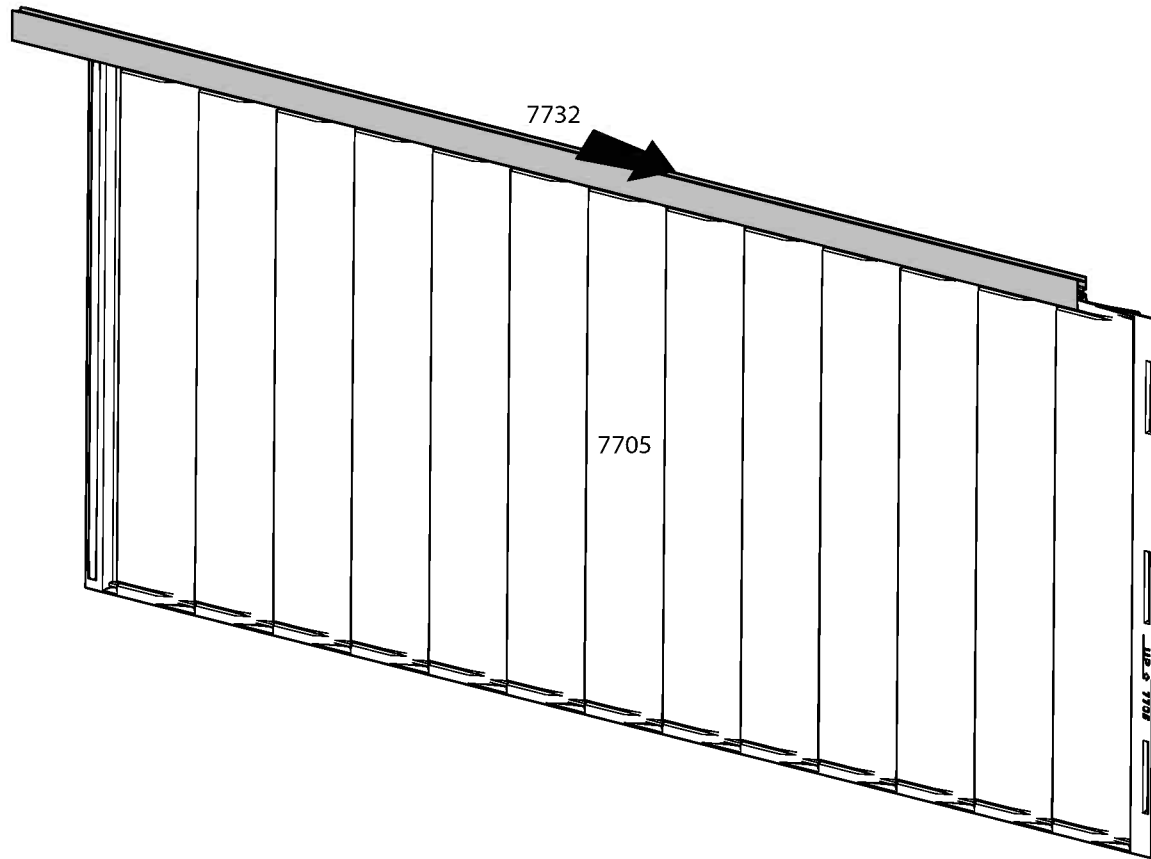
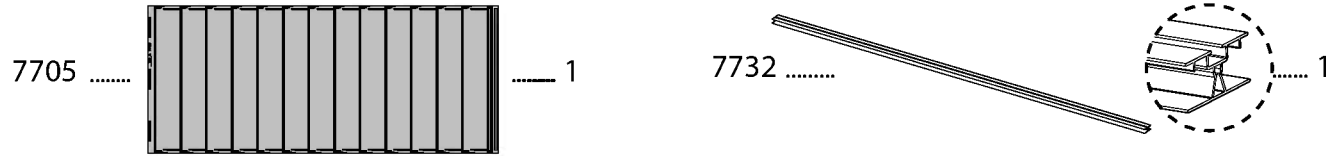
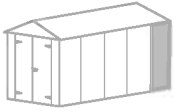

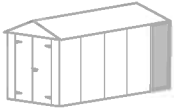

7720 1 411 1 466 1 7441..... 1

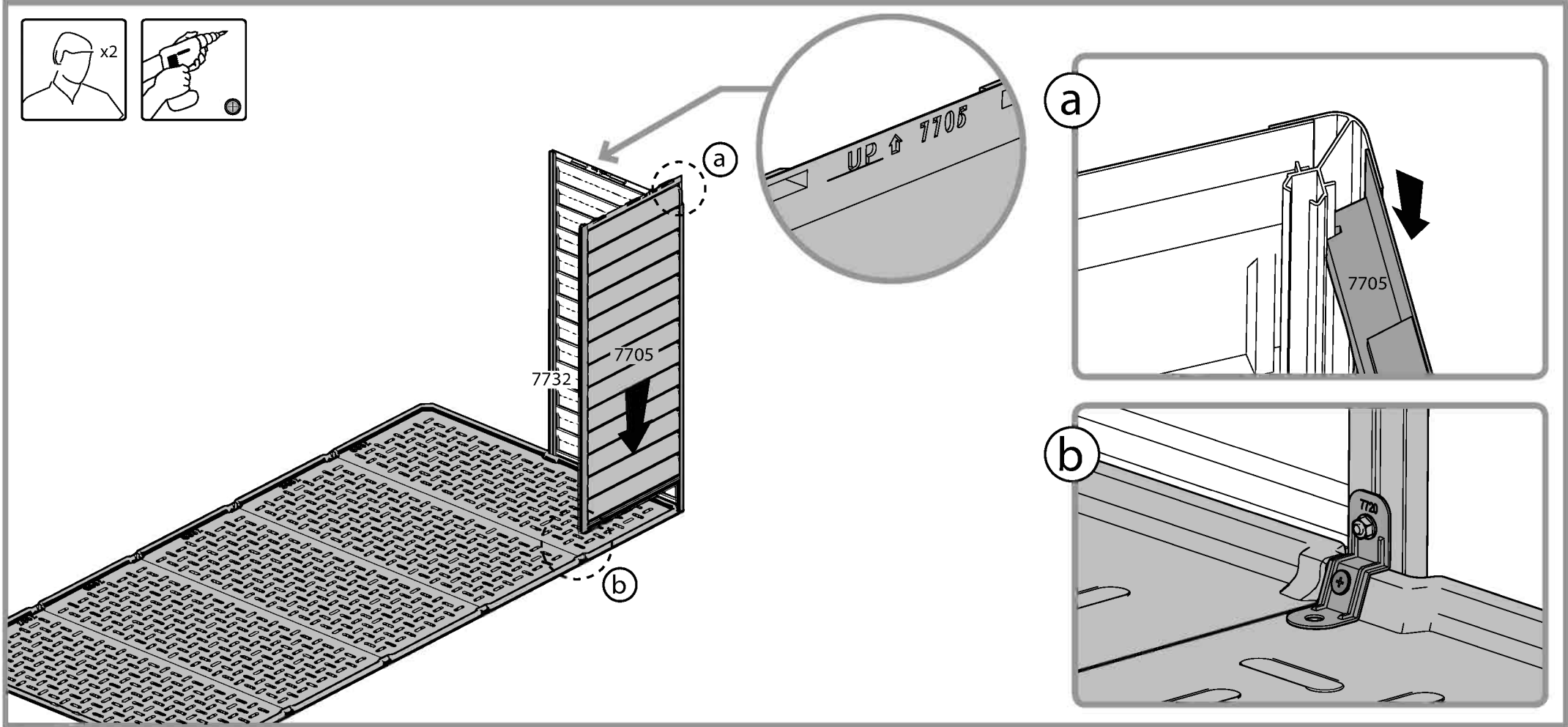
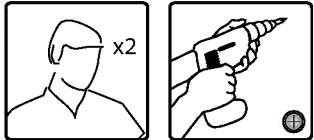

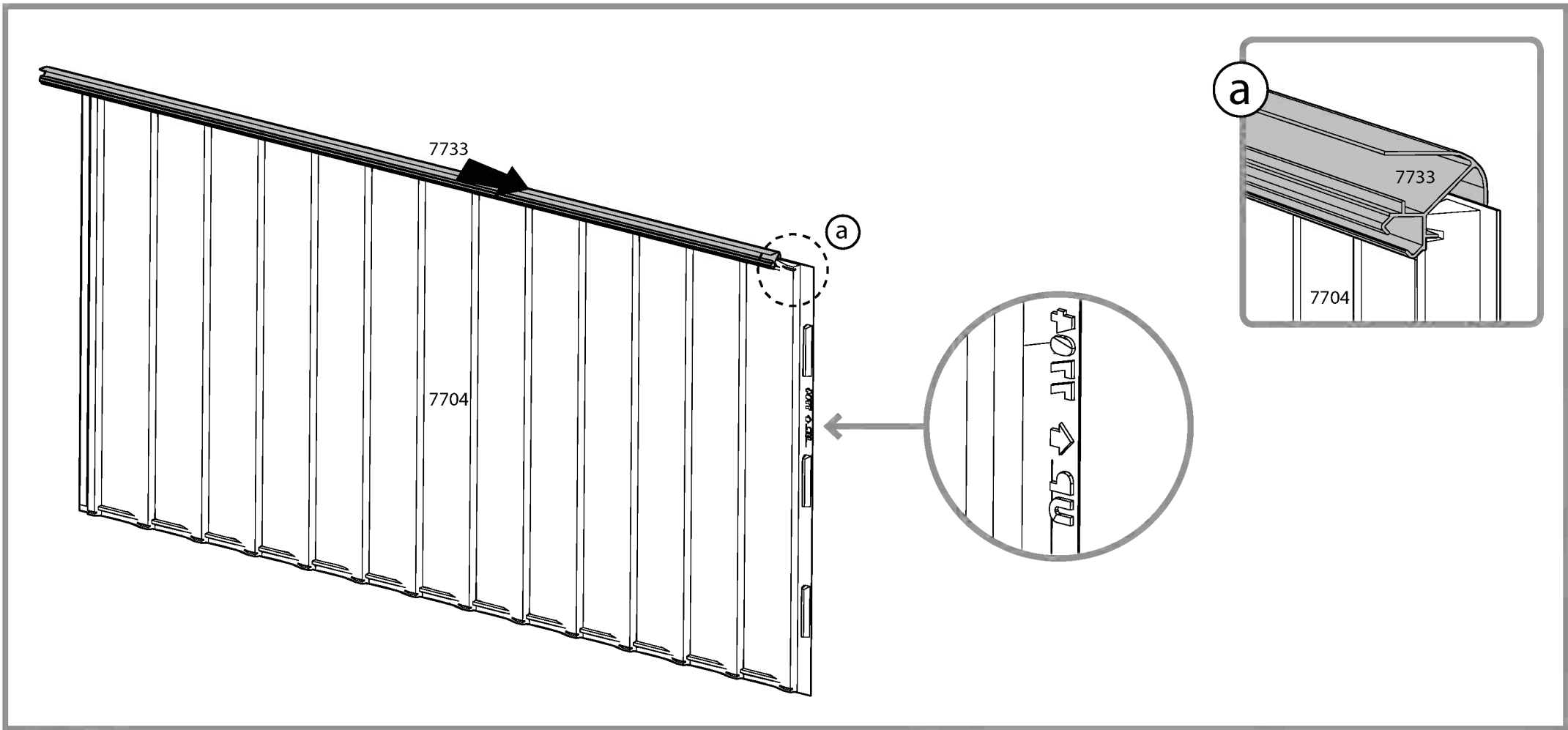
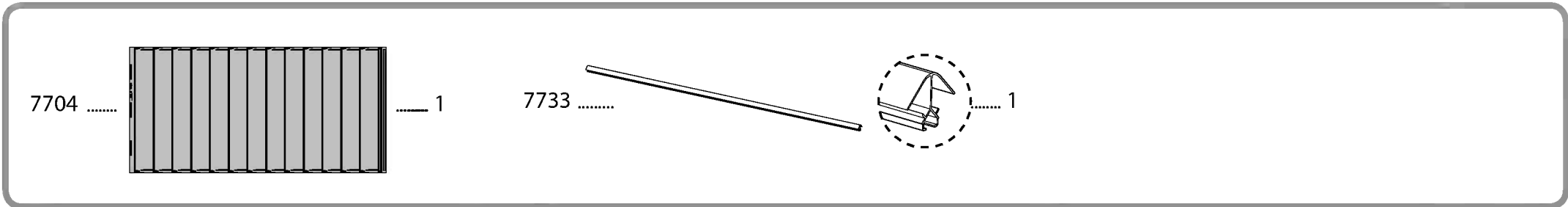
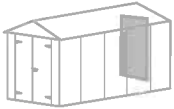

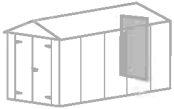



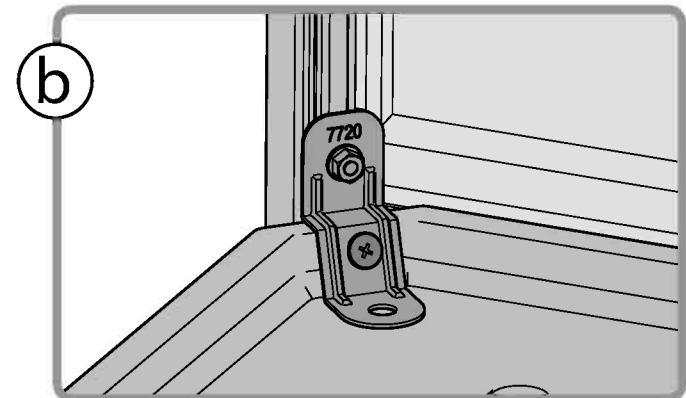
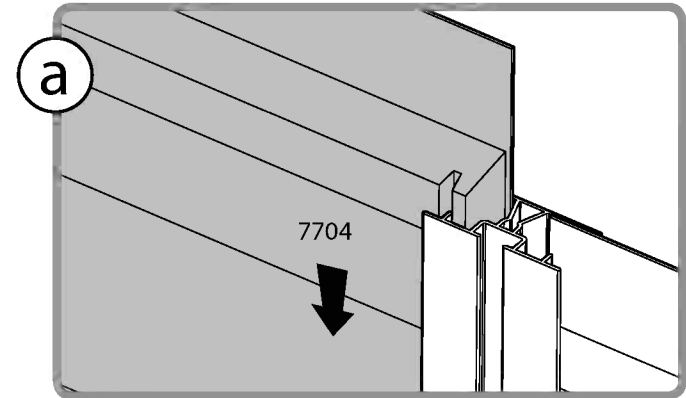
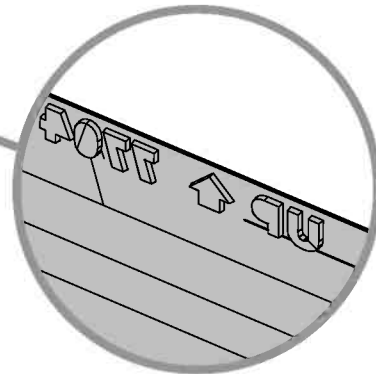
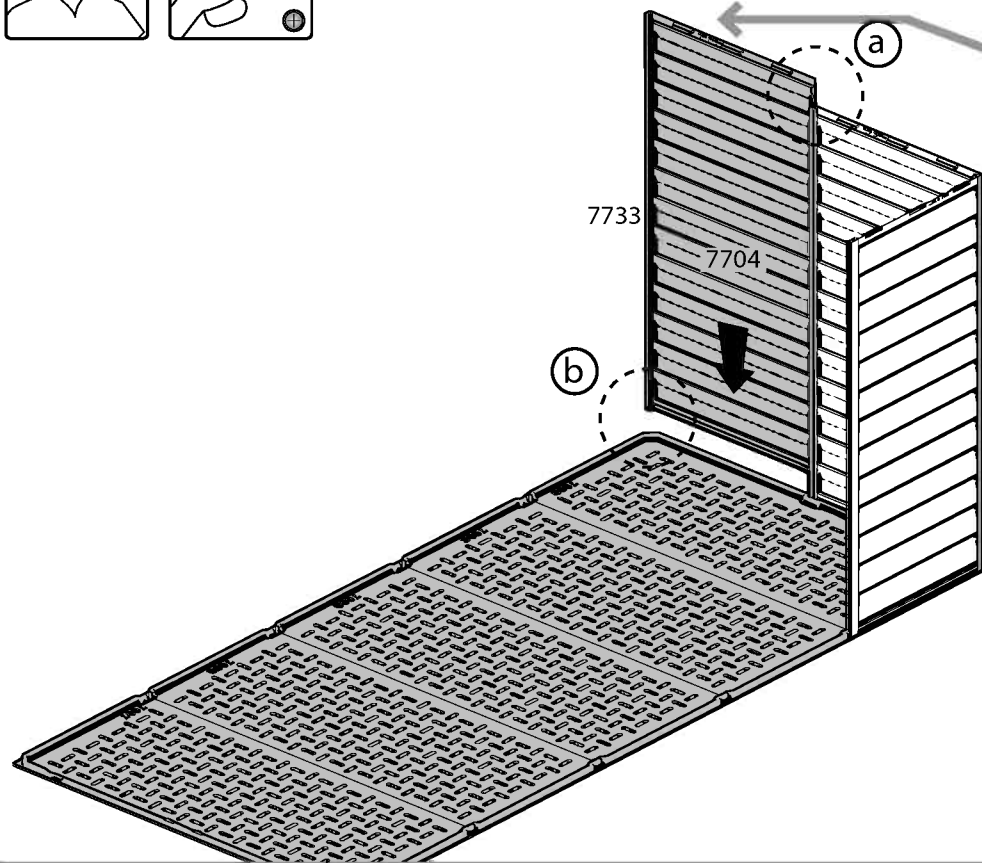
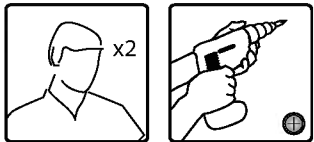

7720 1 411 1 466 1 7441..... 1

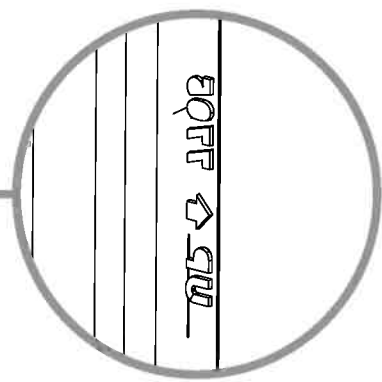
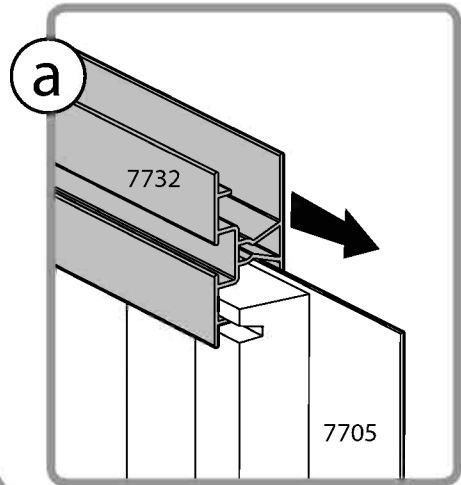
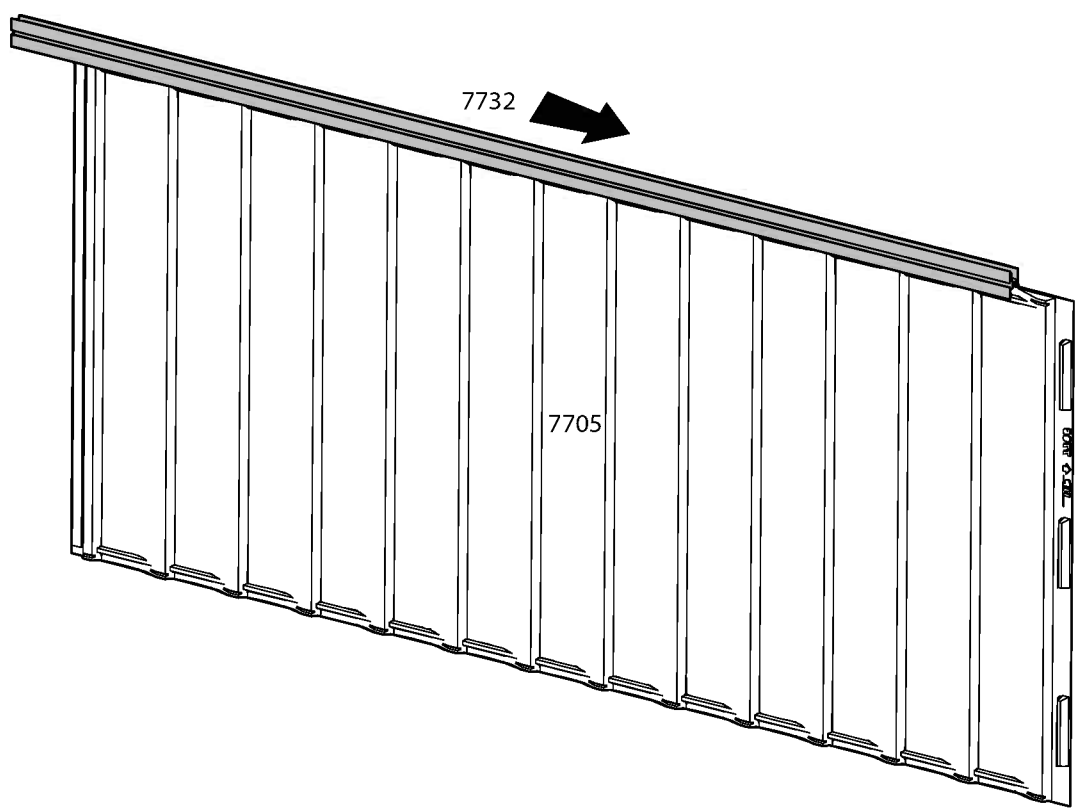
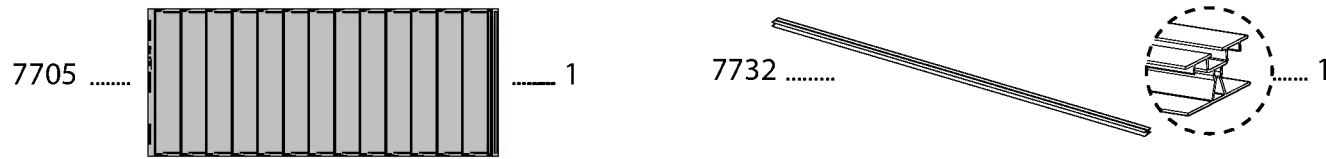
This section lists the required hardware for step 9. It includes one of each of the following items: a metal bracket (7720), a small metal pin (411), a metal nut (466), and a Phillips screw (7441).



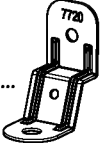



- 7720  1 411  1 466  1 7441.....  1

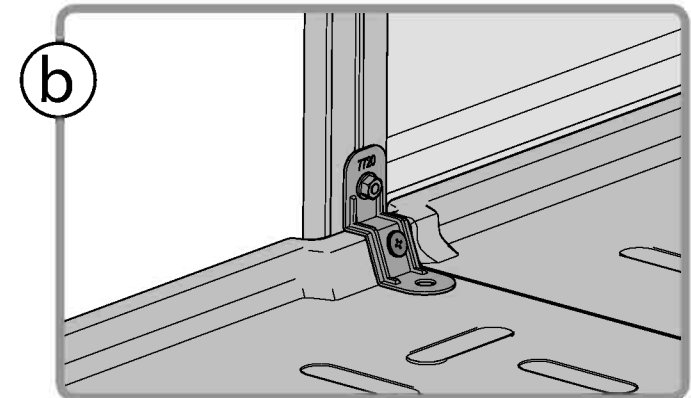
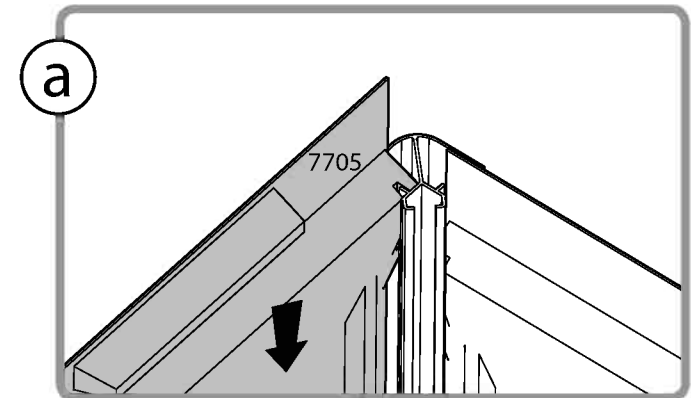
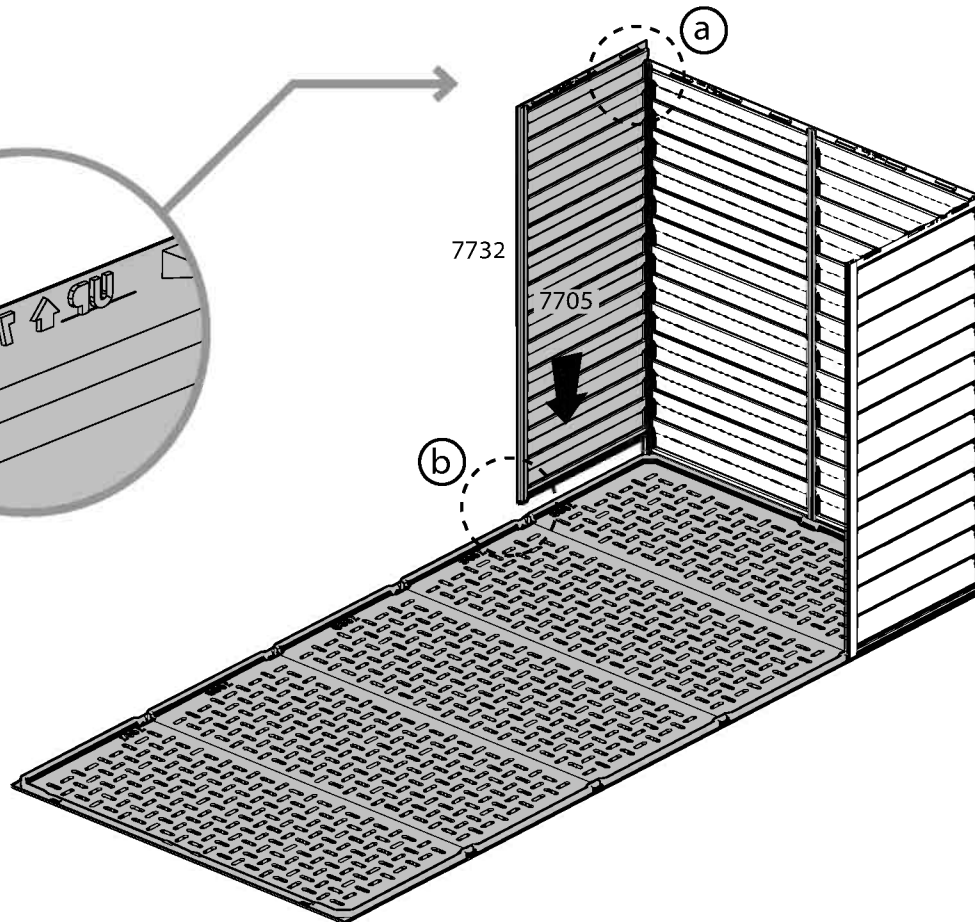
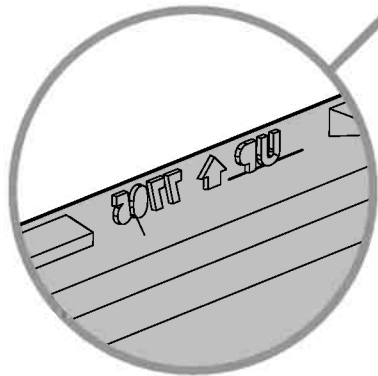
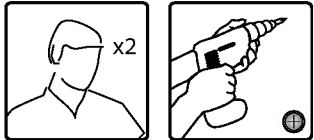

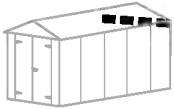



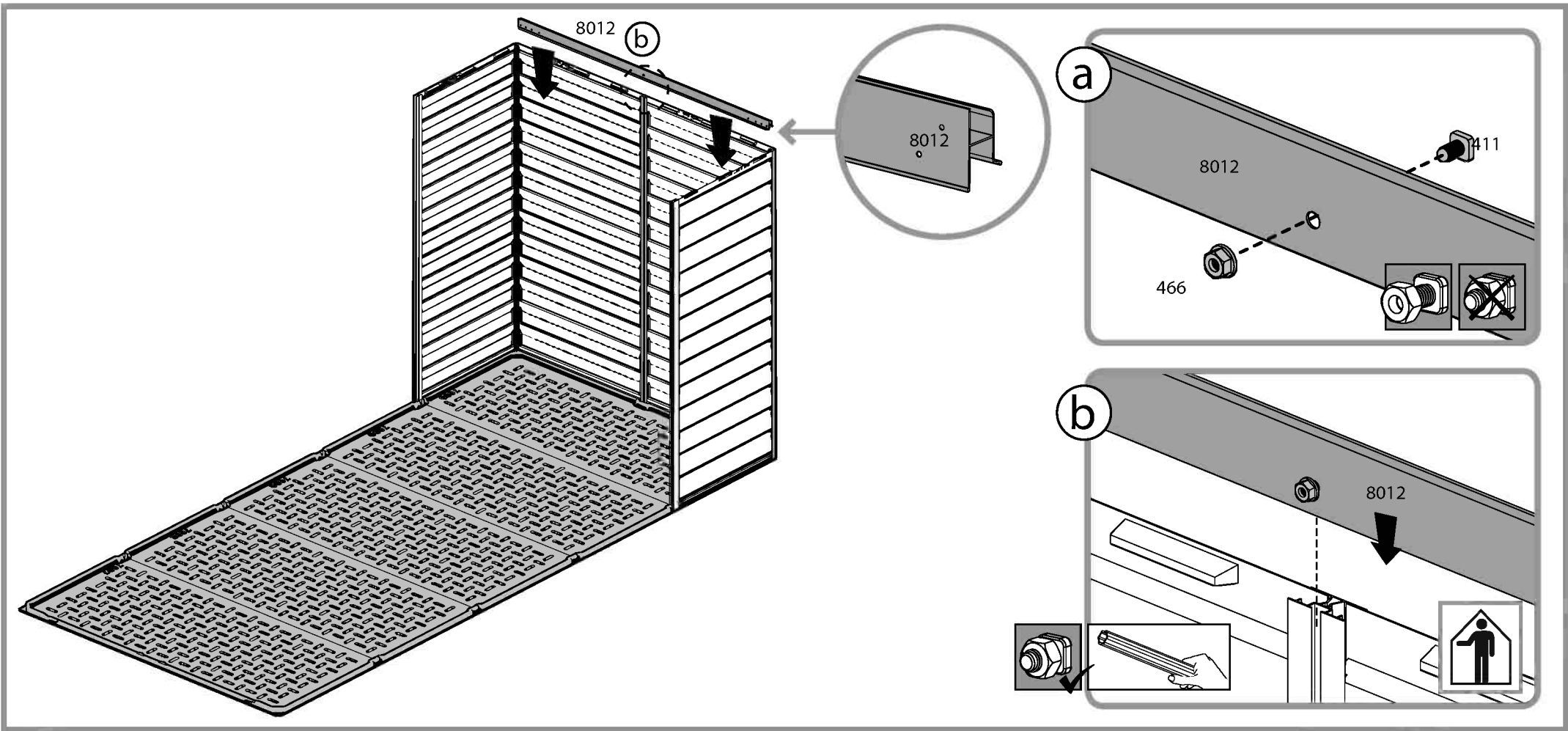

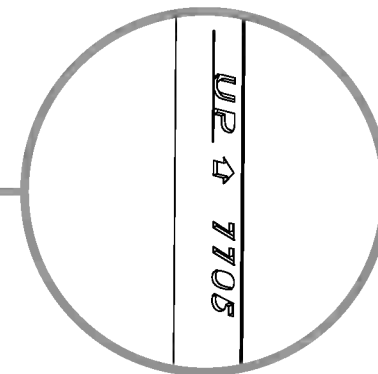
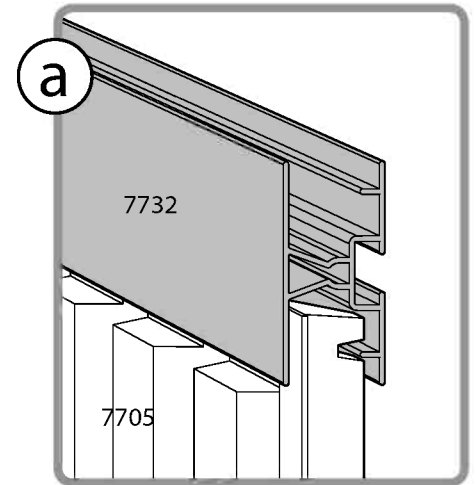
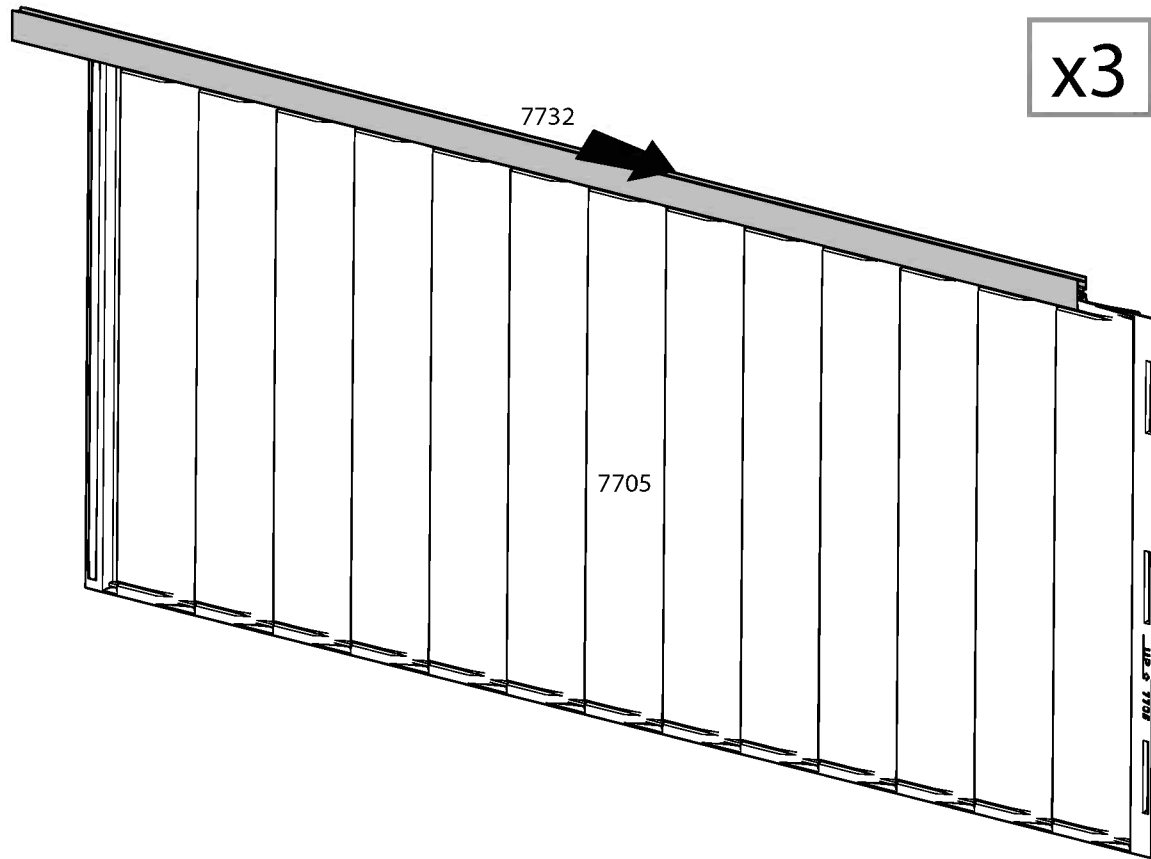
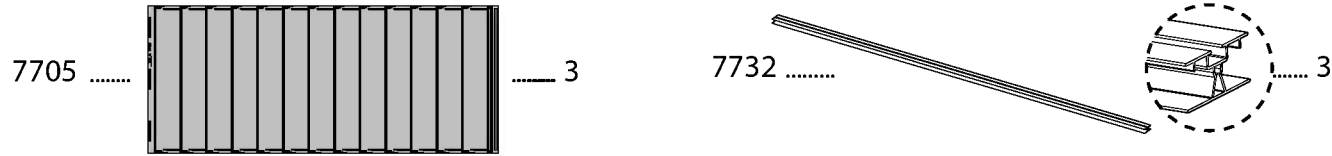
- 8012  1
- 411  1
- 466  1



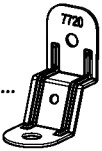



- 7720  3 411  3 466  3 7441.....  3

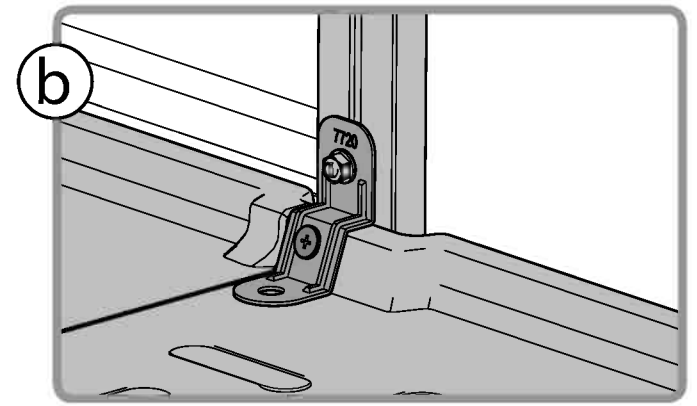
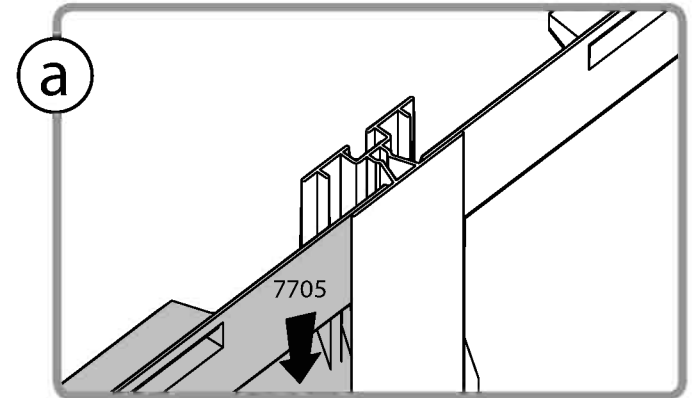
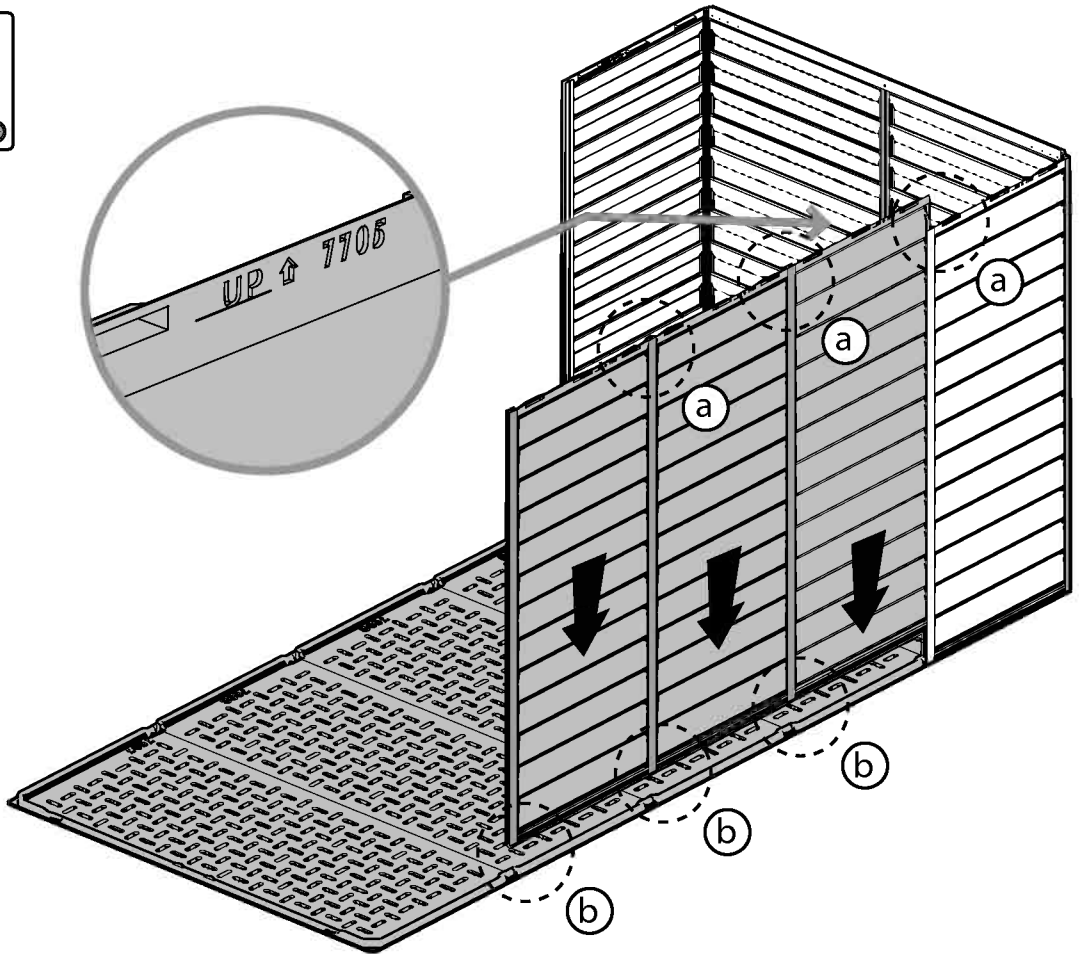
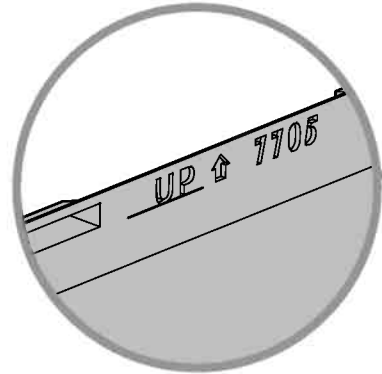
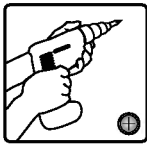

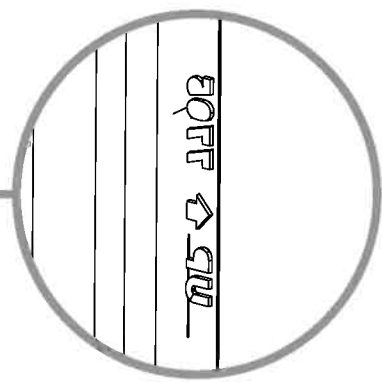
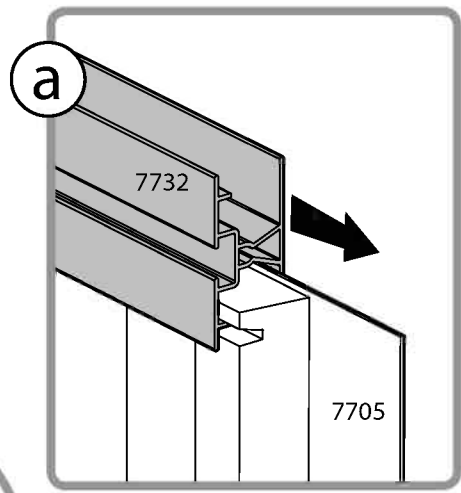
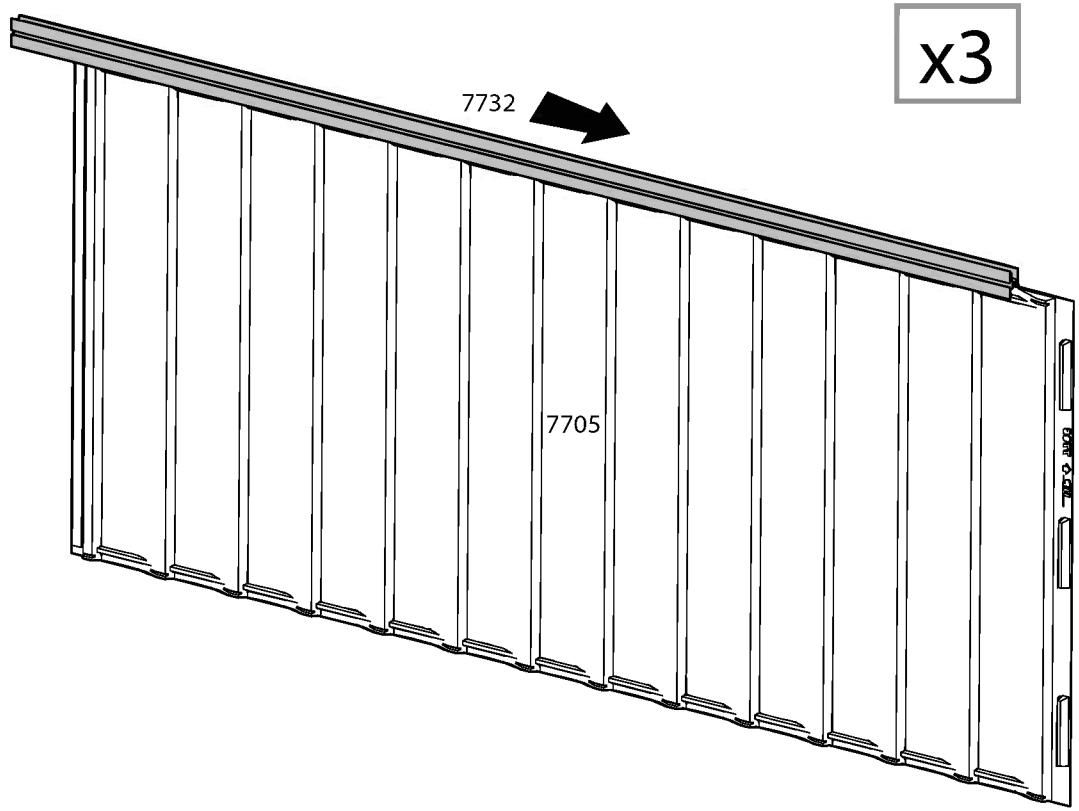
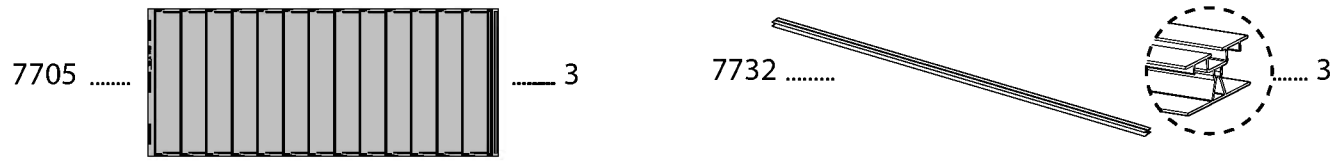
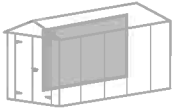

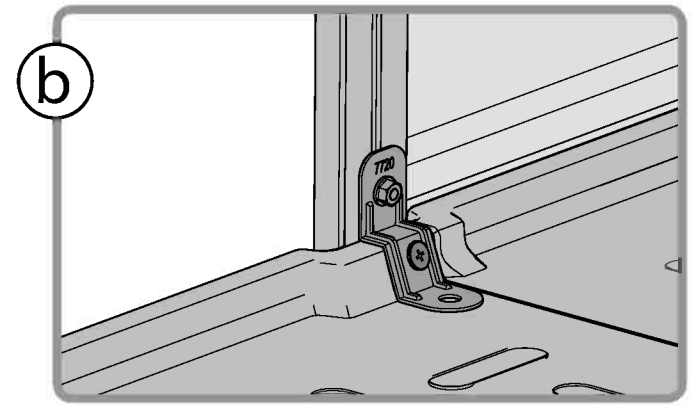
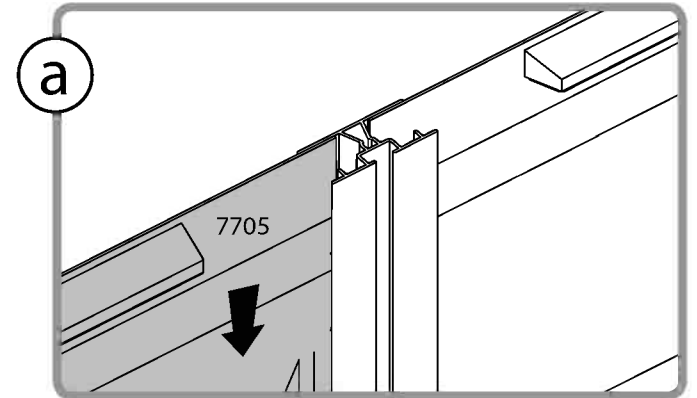
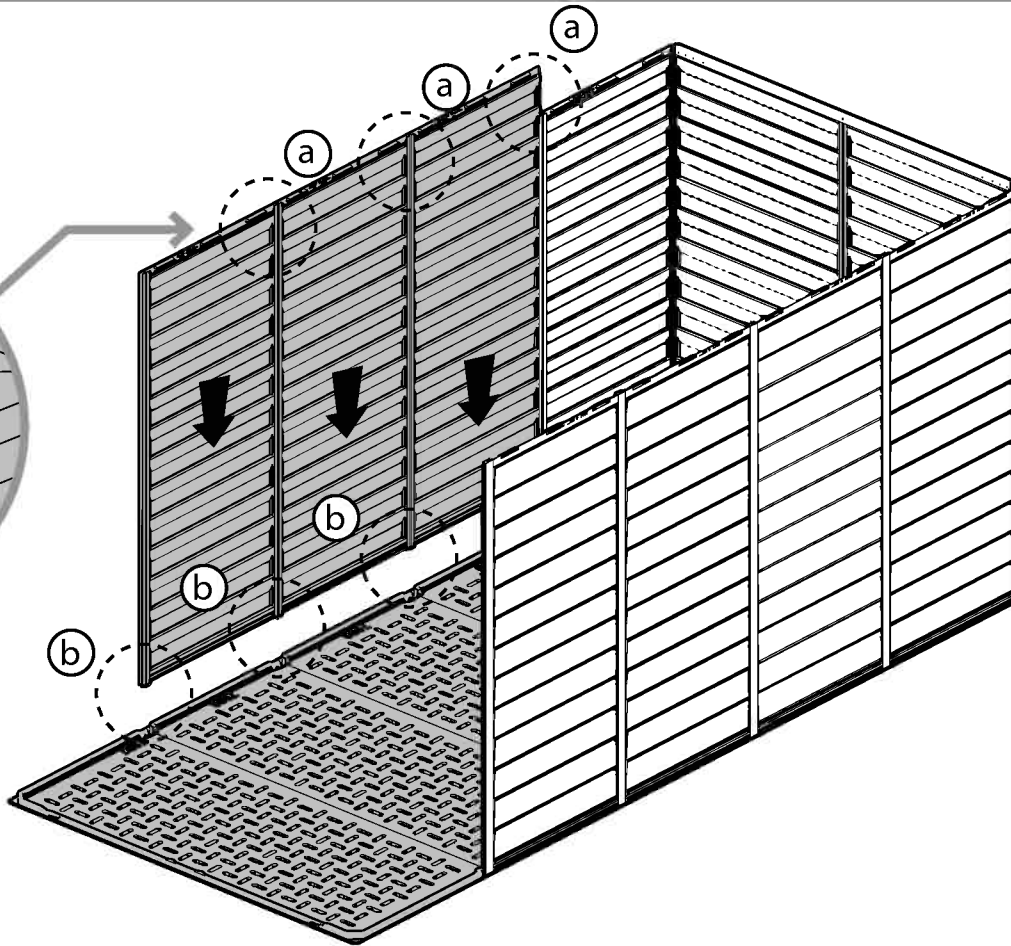
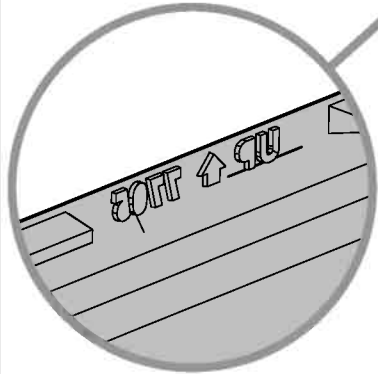
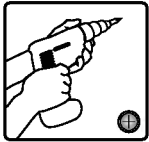
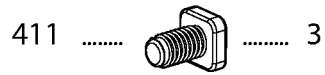
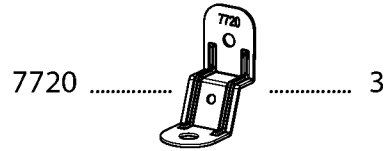
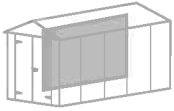

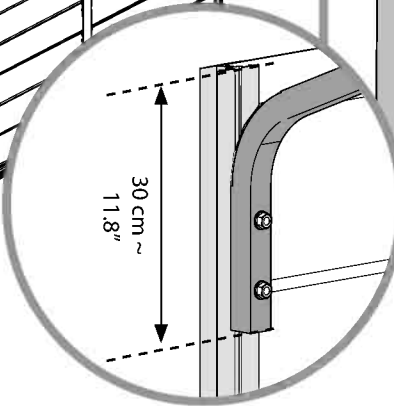
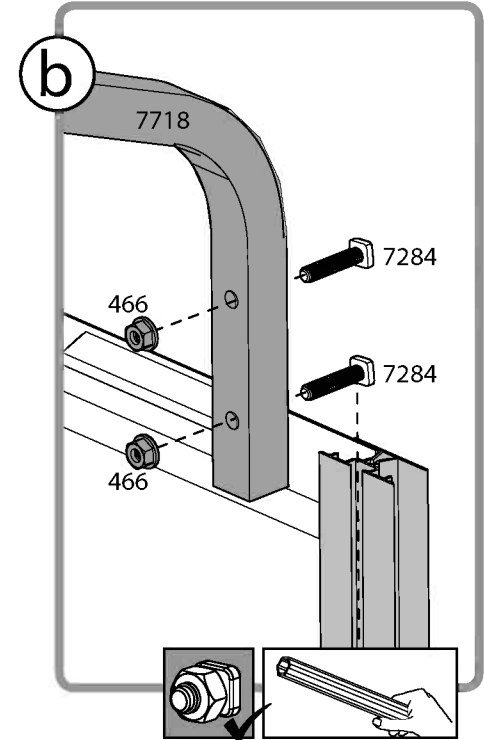
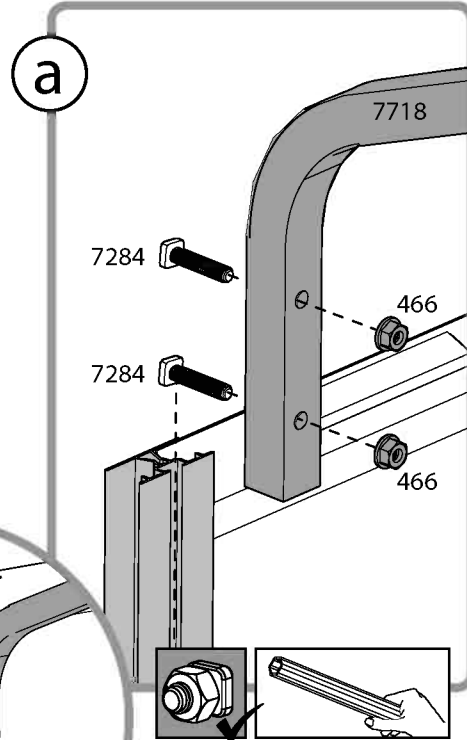
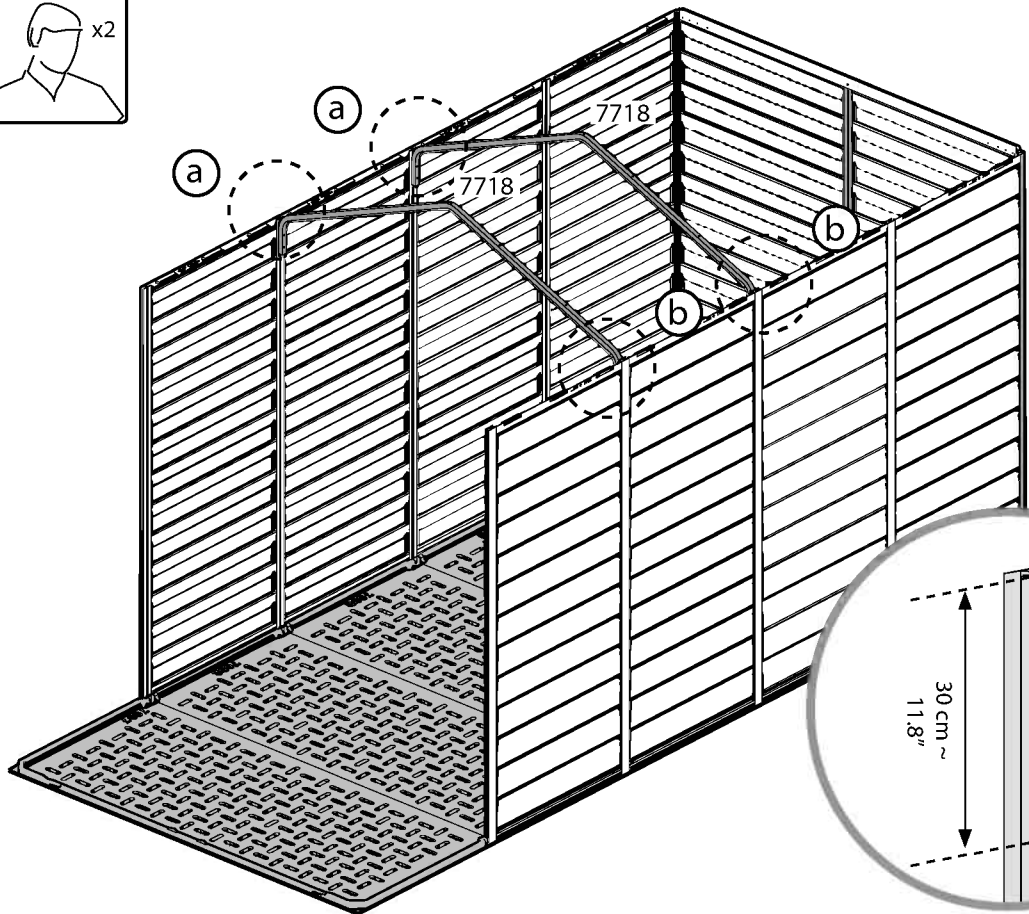
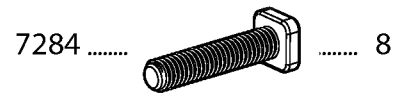
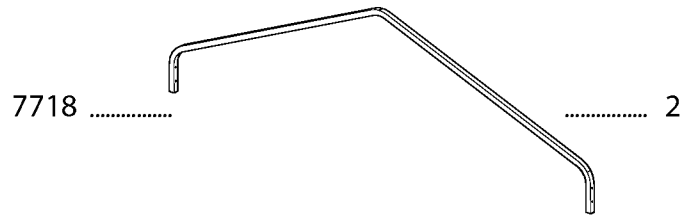

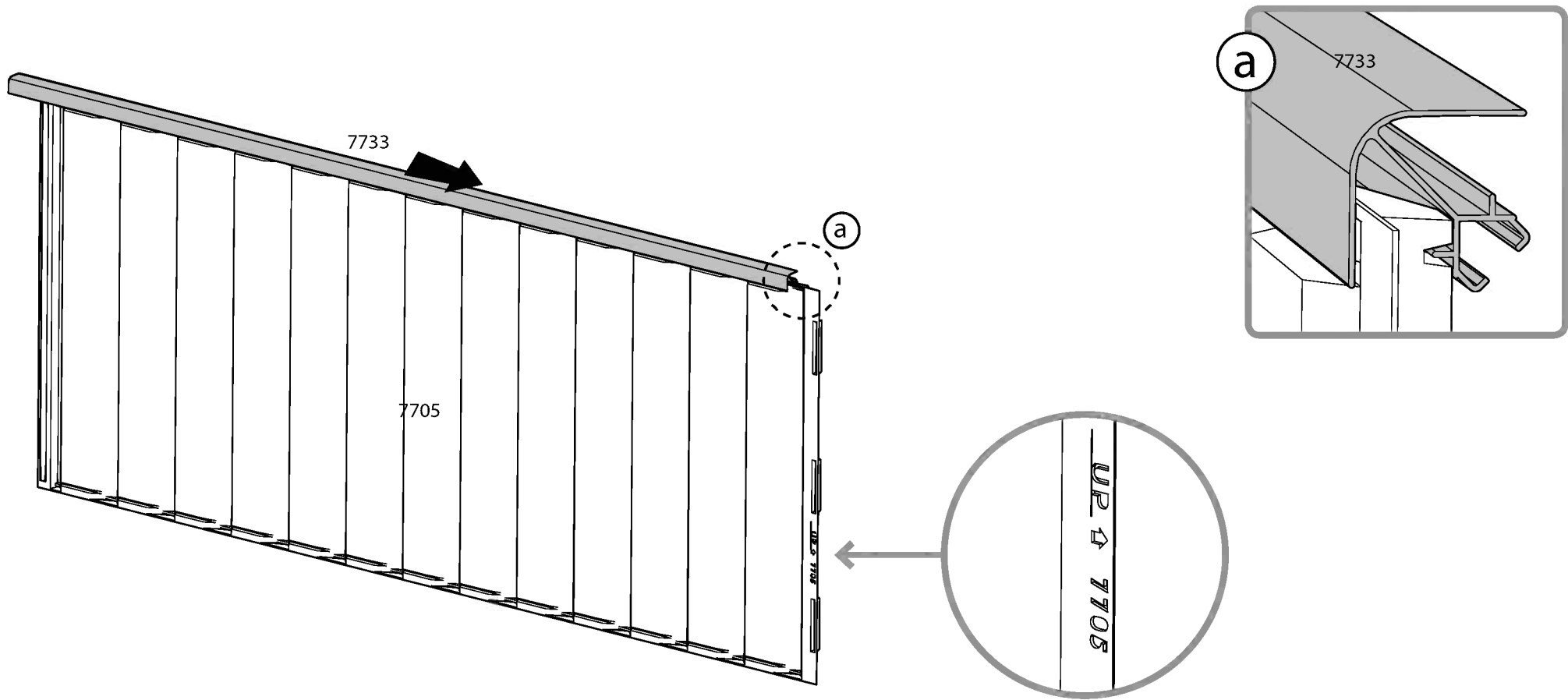
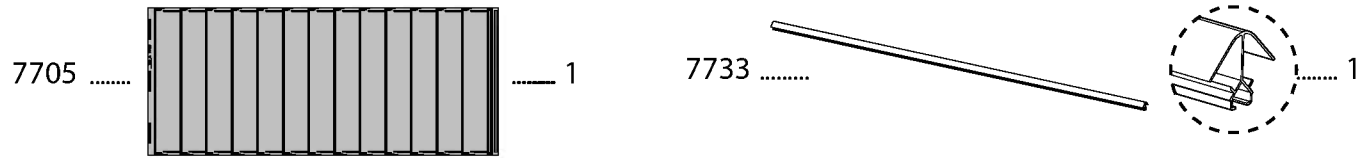

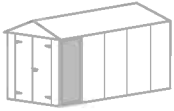

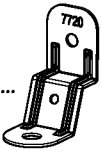





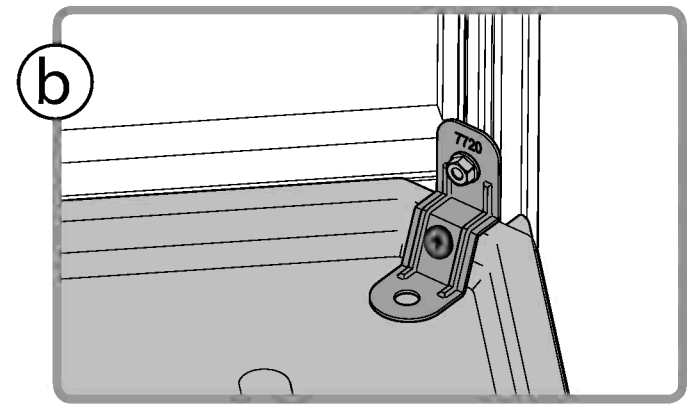
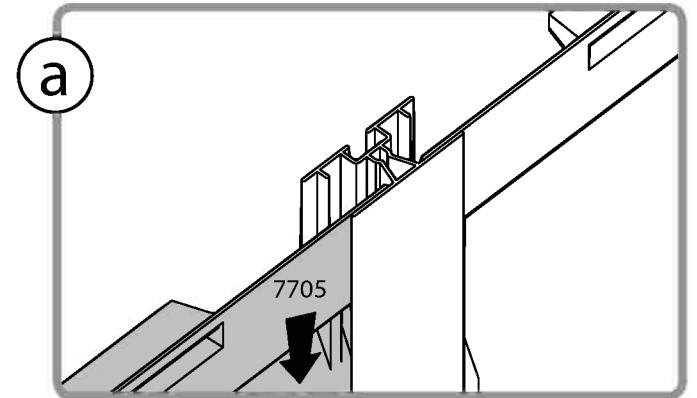
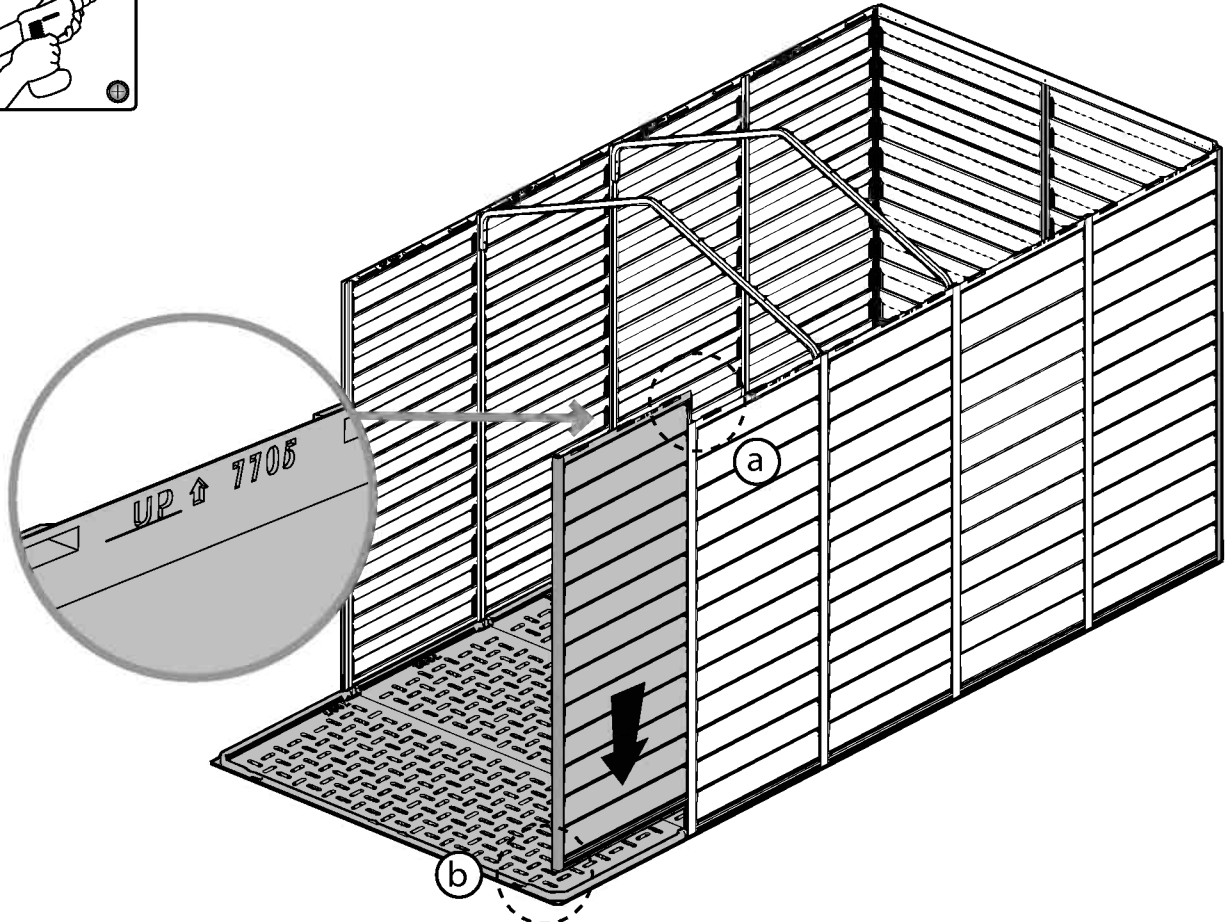
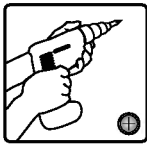

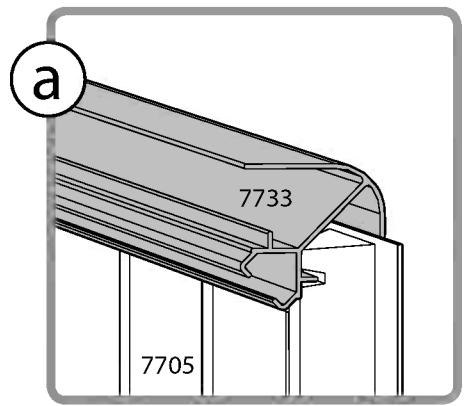
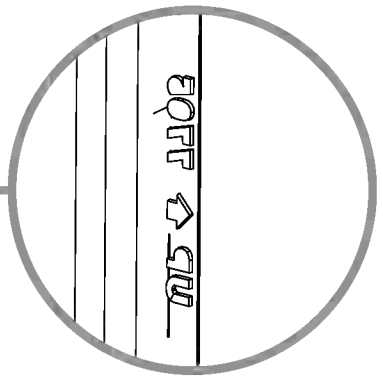
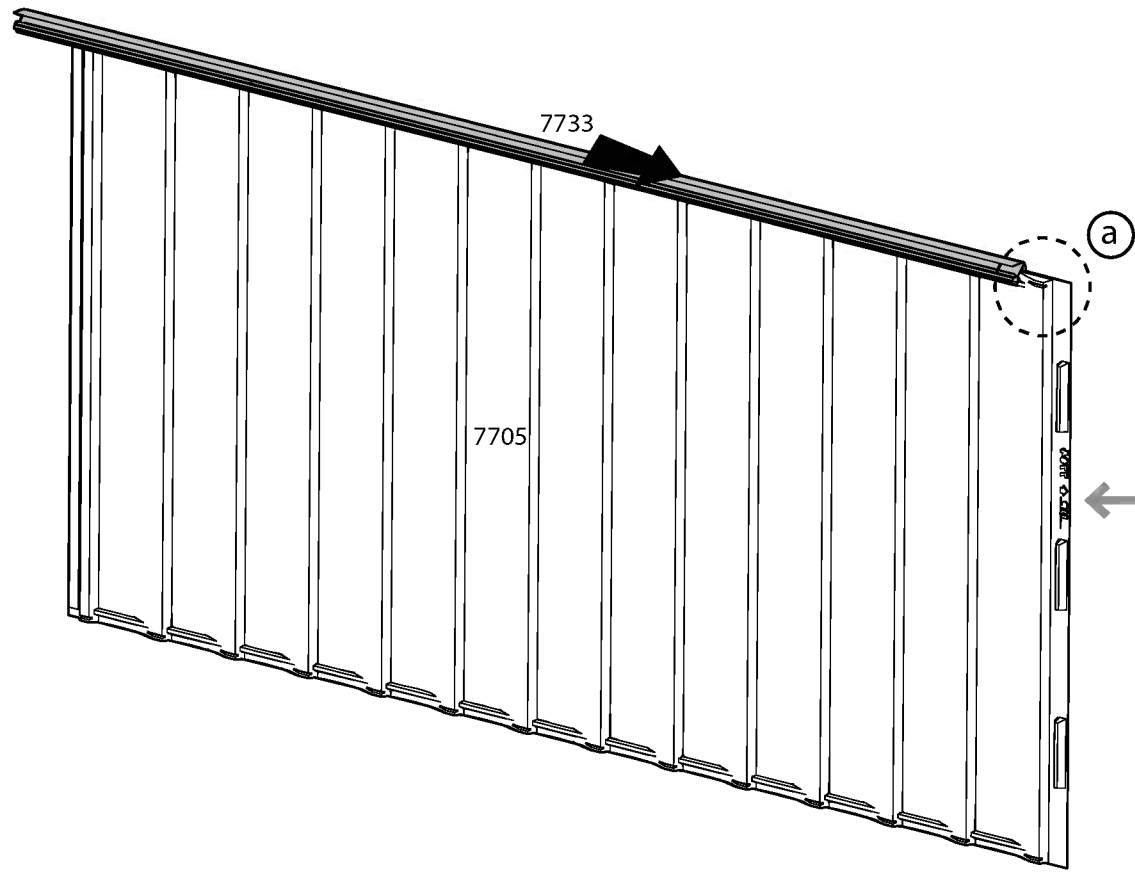
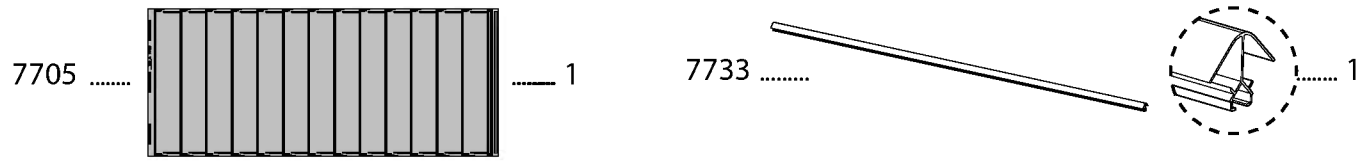
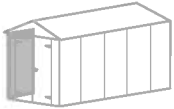
- 7720  1
- 411  1
- 466  1
- 7441.....  1

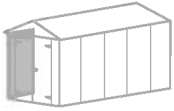

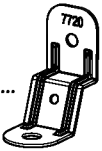



- 7720  1 411  1 466  1 7441.....  1

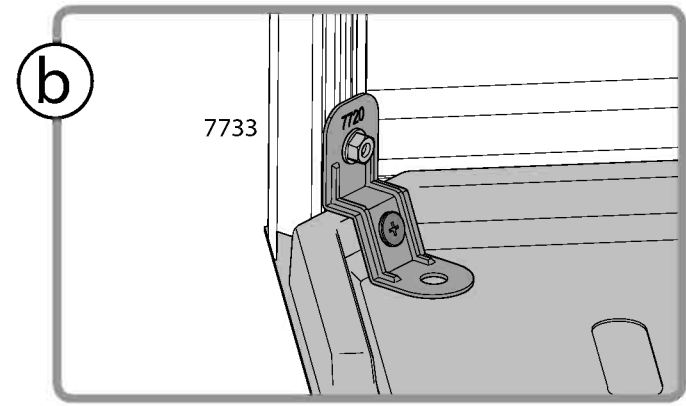
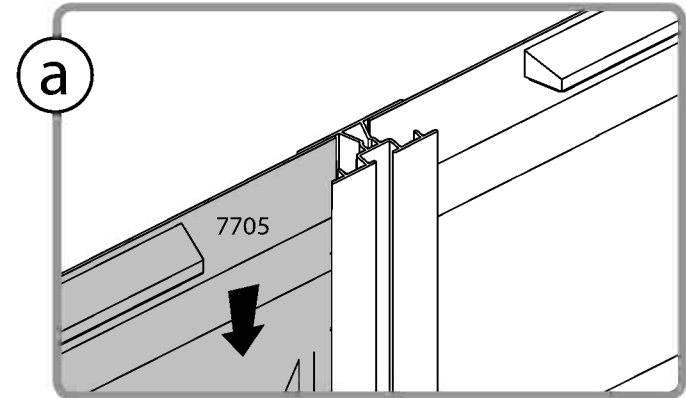
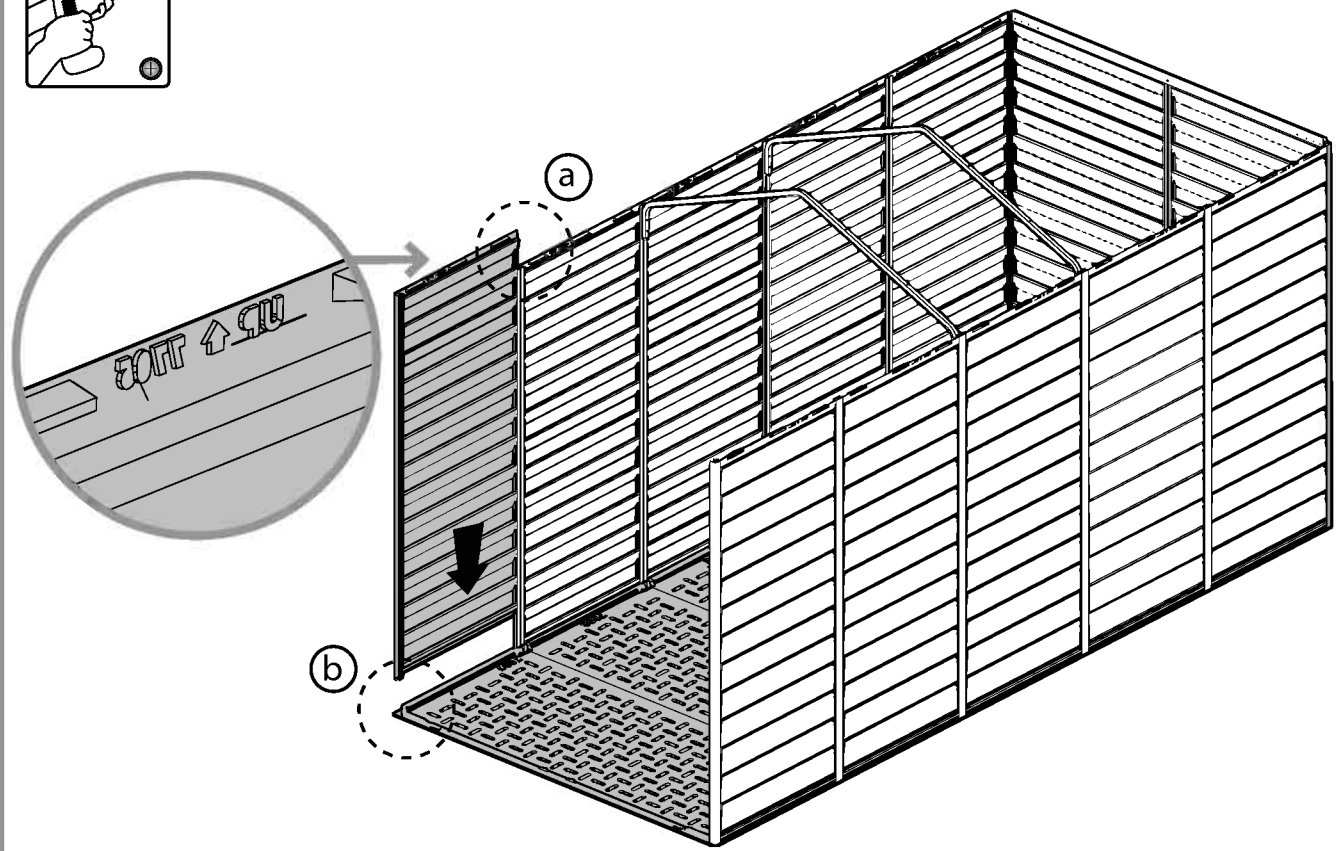
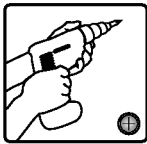

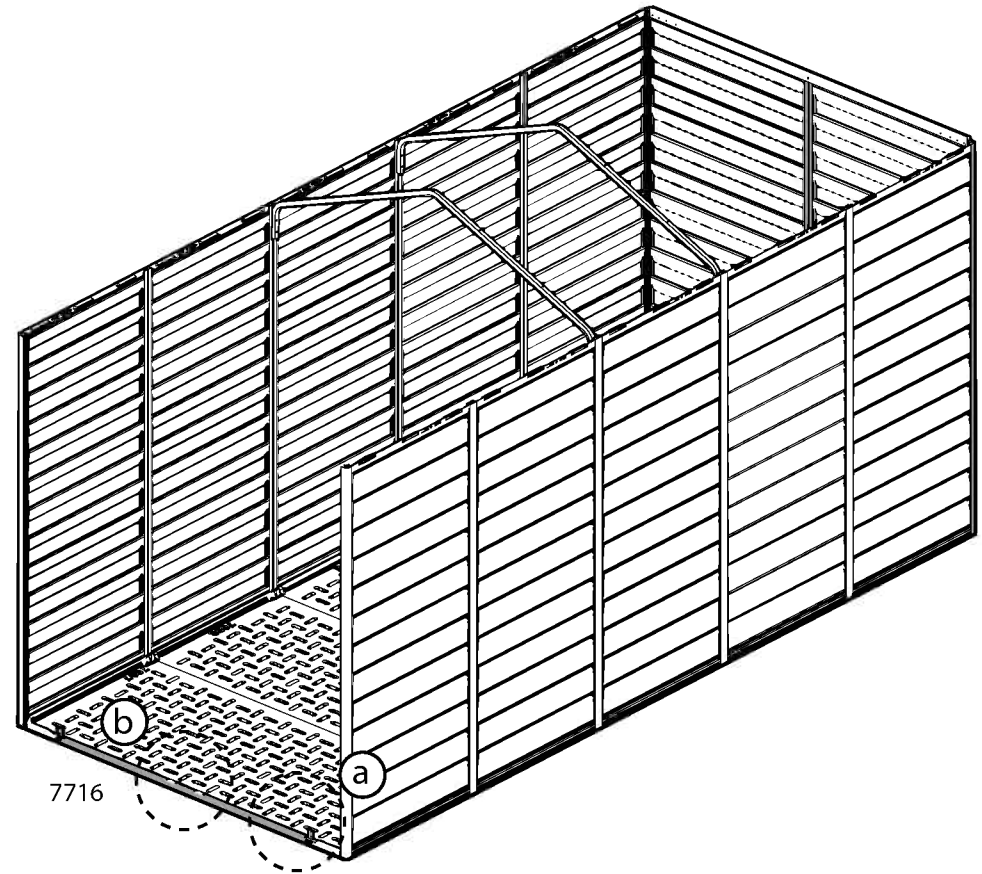
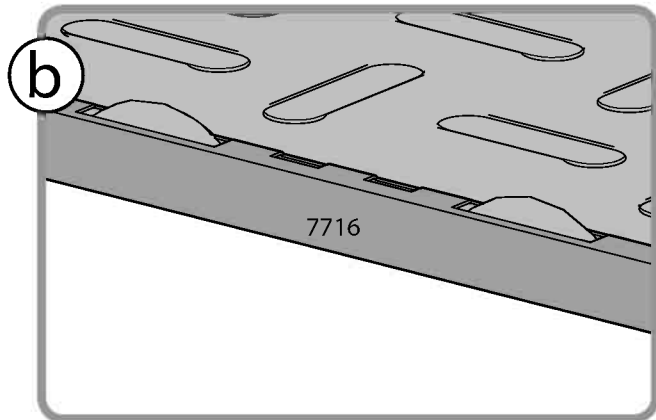
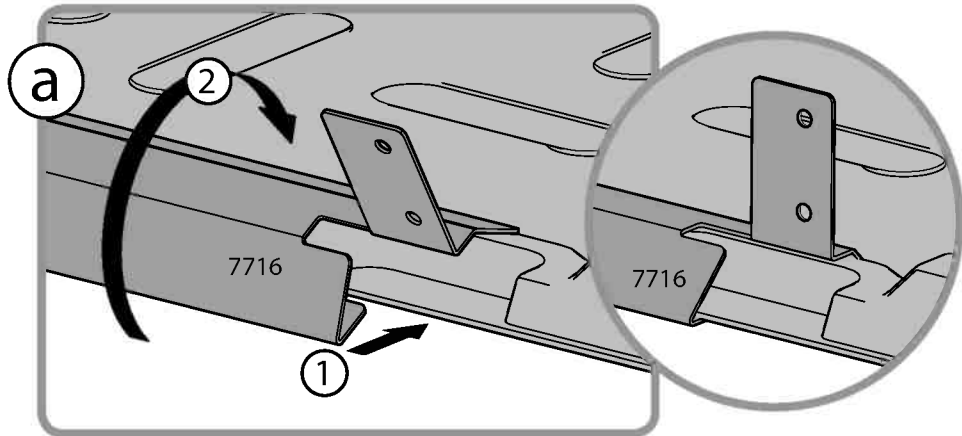
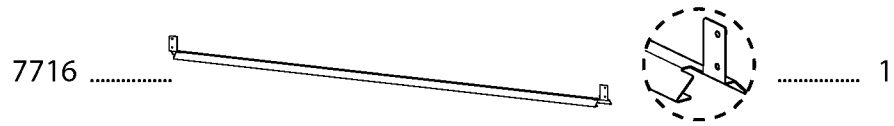

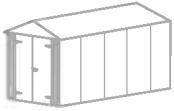

7706 2



7725



2

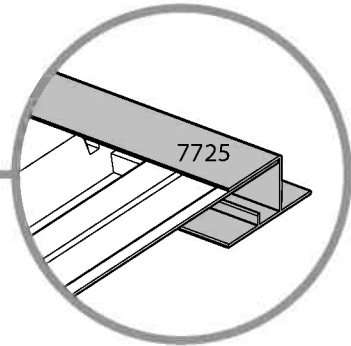
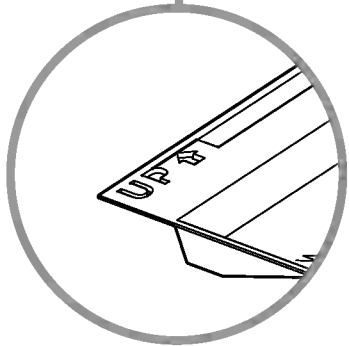
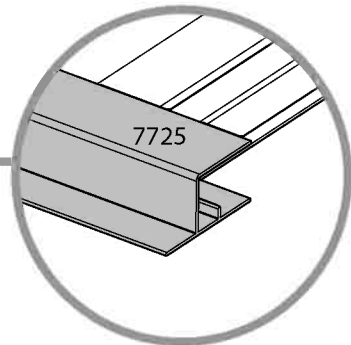
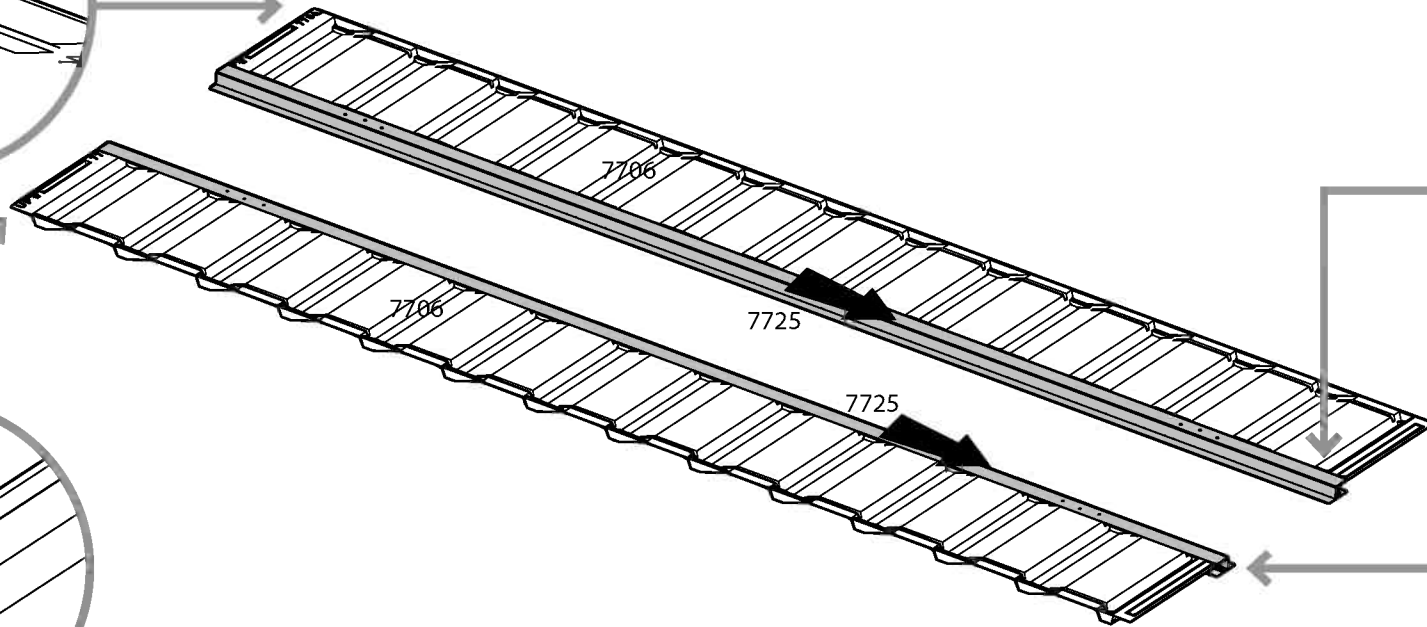
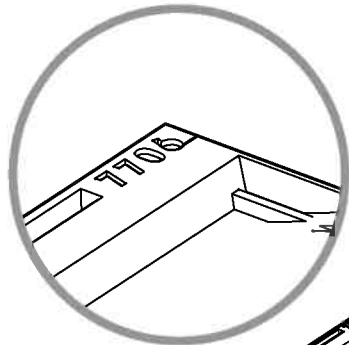

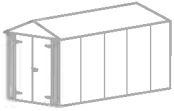

7442 4

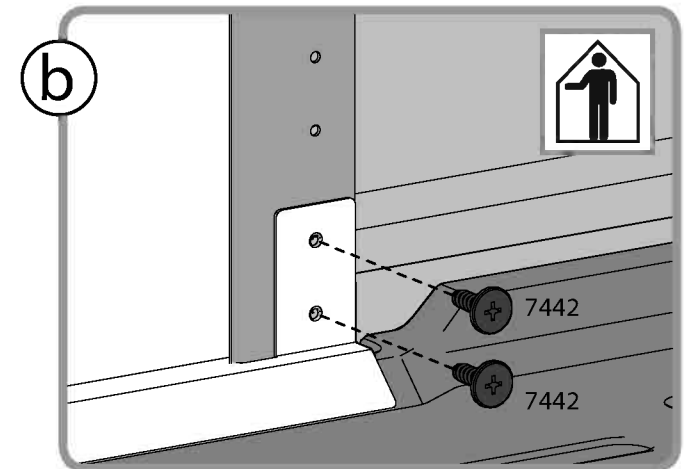
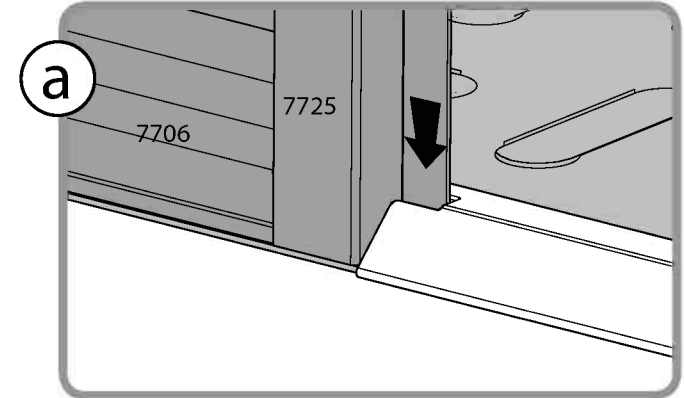
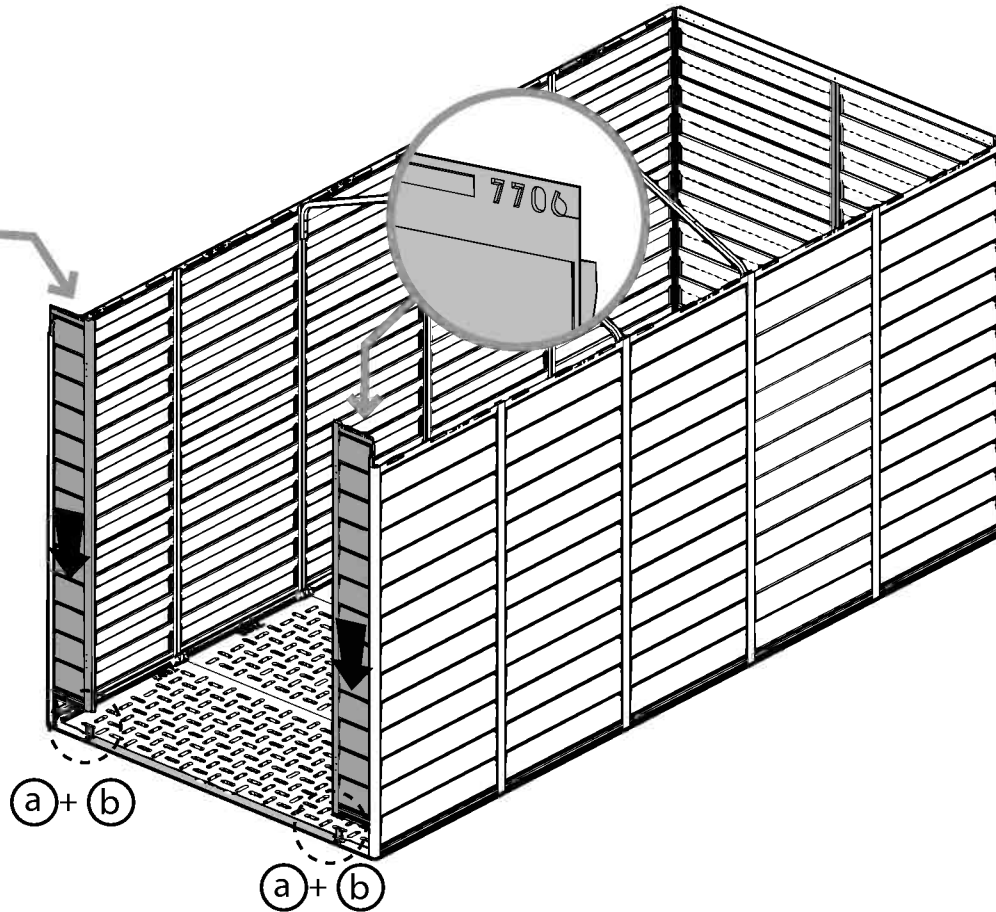
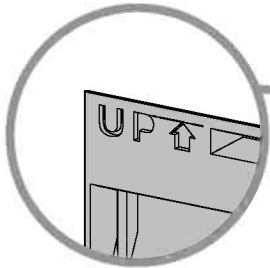
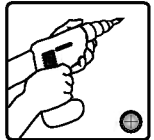

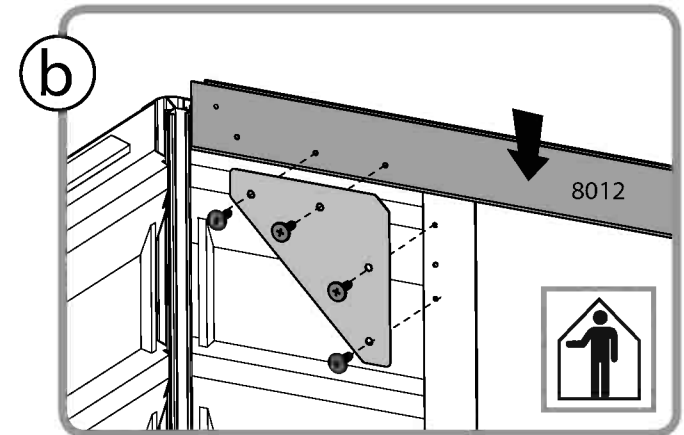
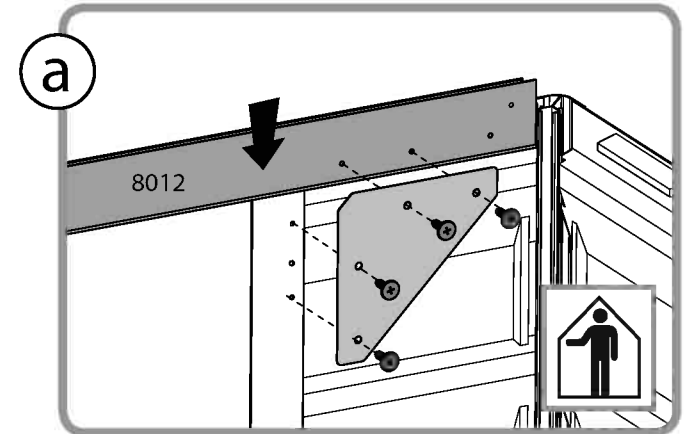
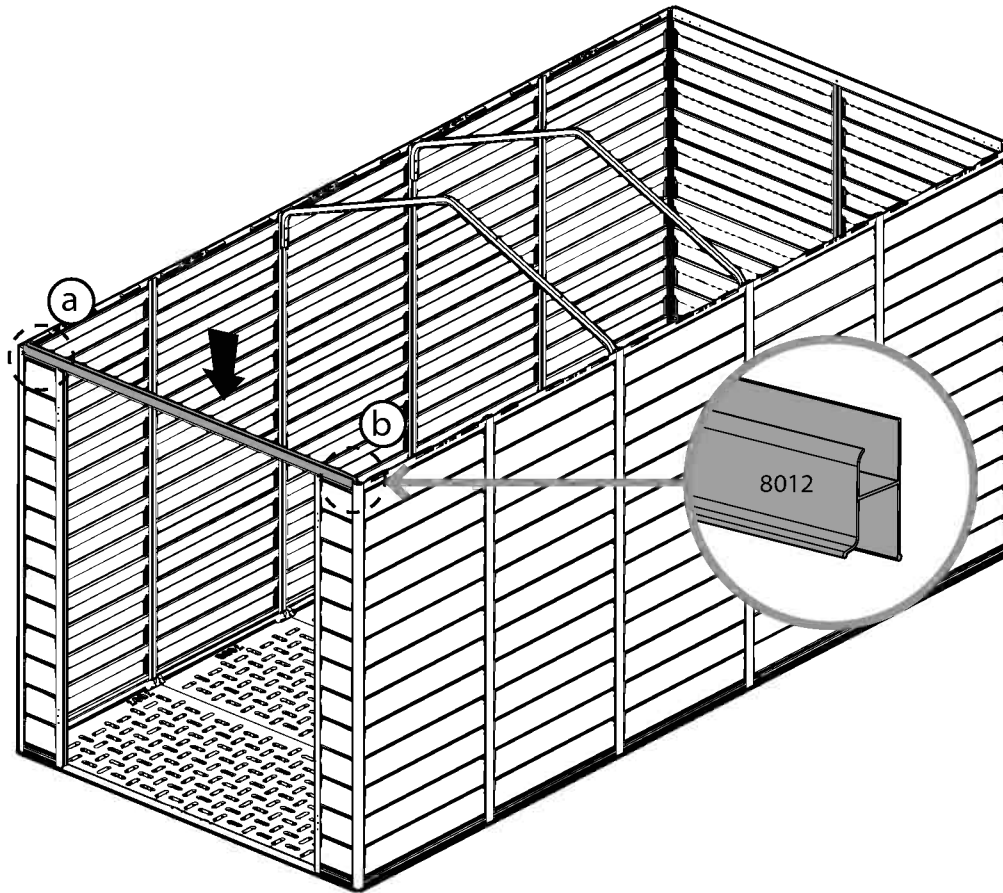
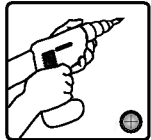
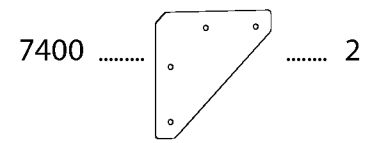
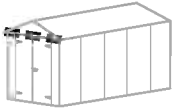

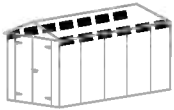

8110
7976
7985
411
466

..... 2
..... 4
..... 4
..... 16
..... 16

a

b

411

7976 / 7974

466

466

466

7985

7976

8110

7976

8110

7976

7976

8110

7976

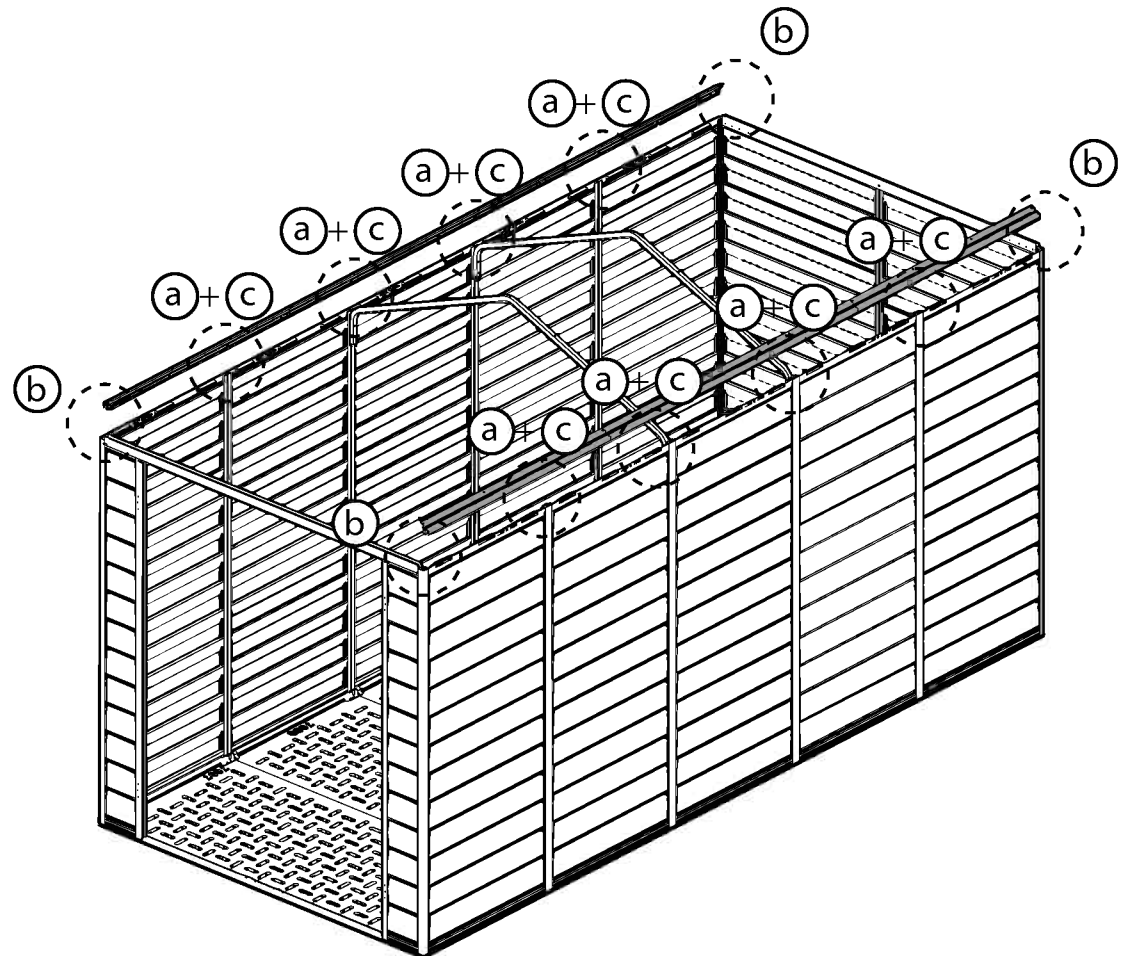
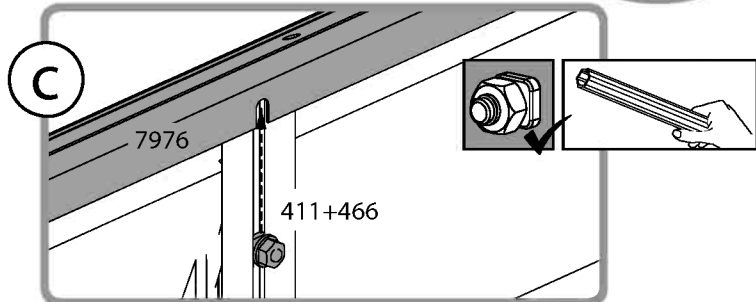
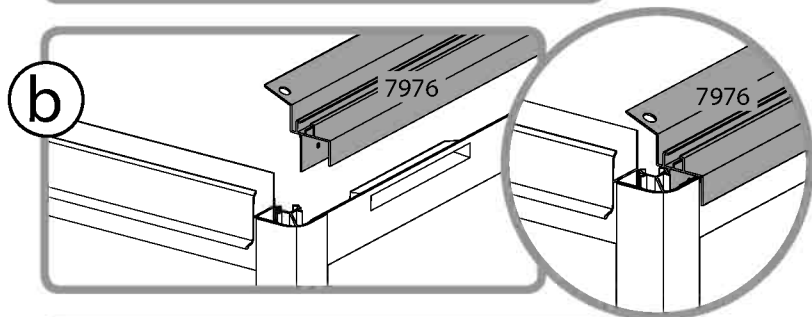
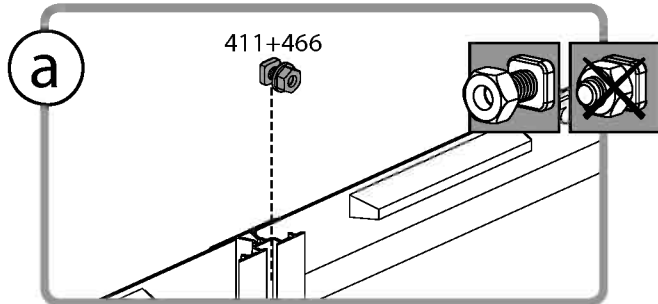
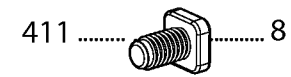
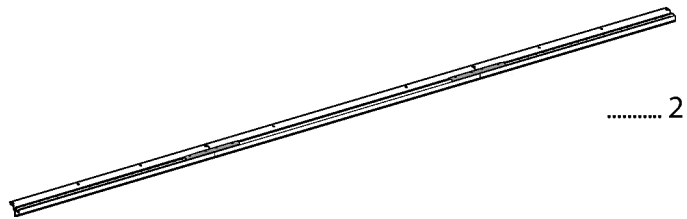
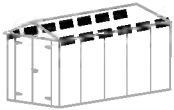

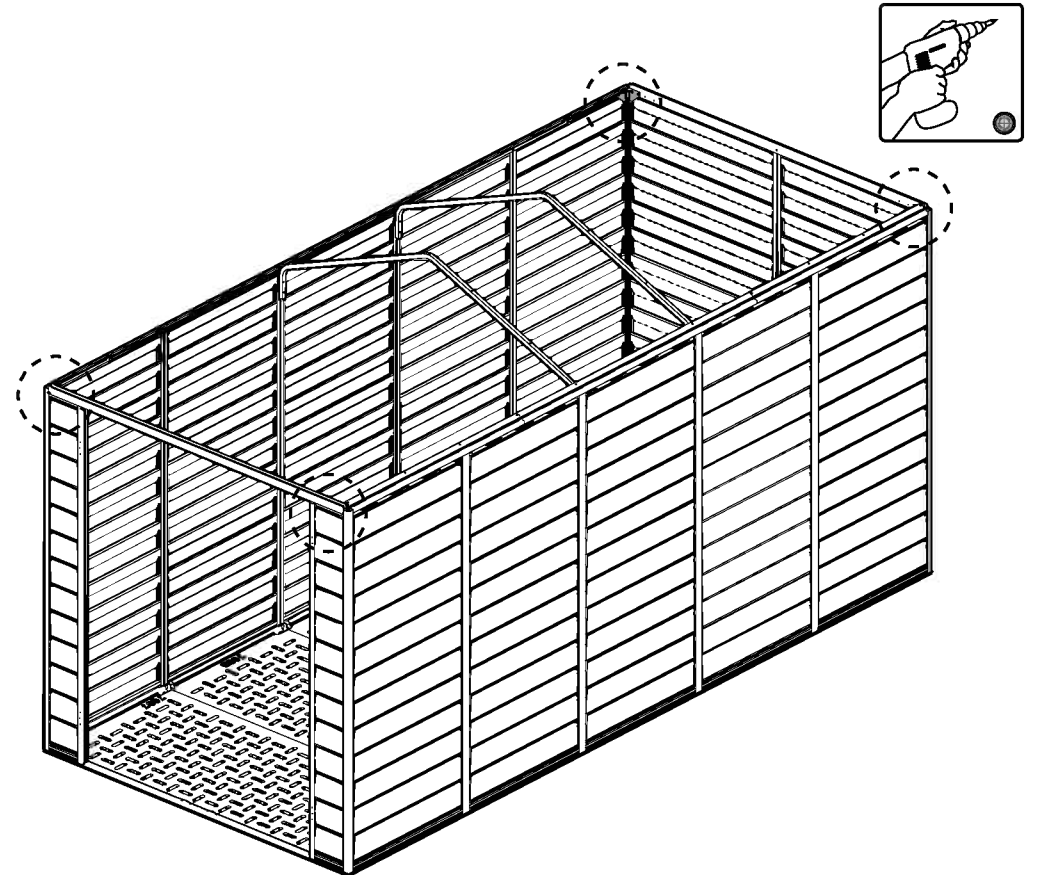
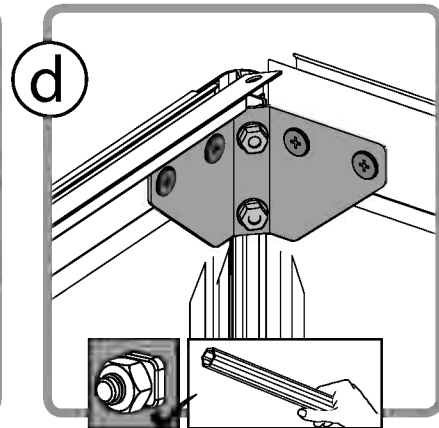
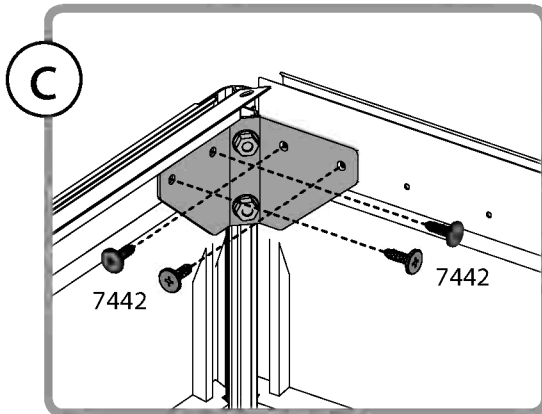
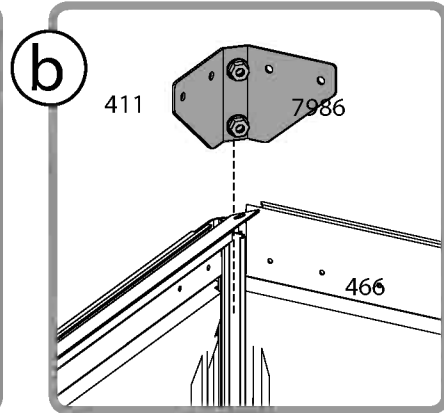
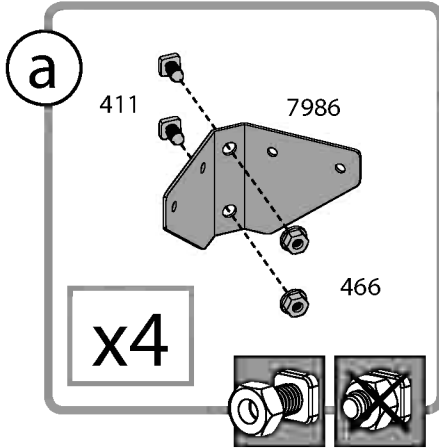
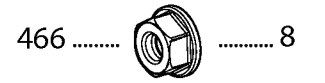
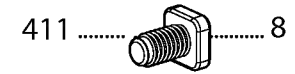
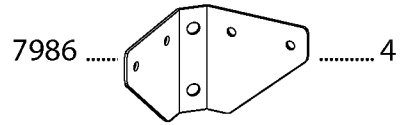
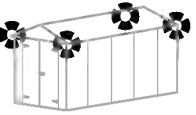

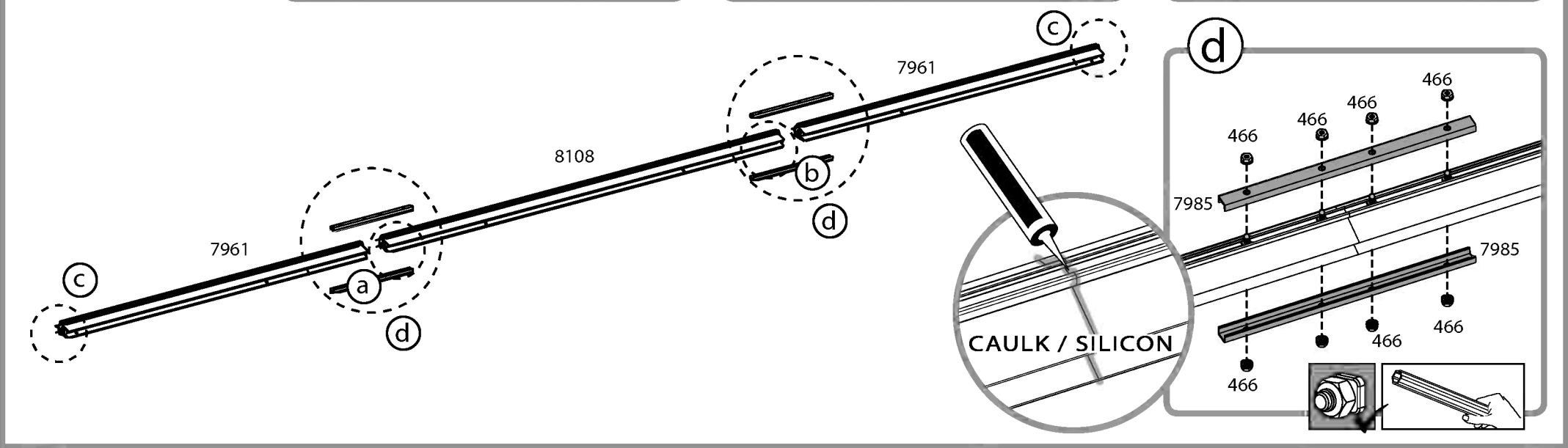
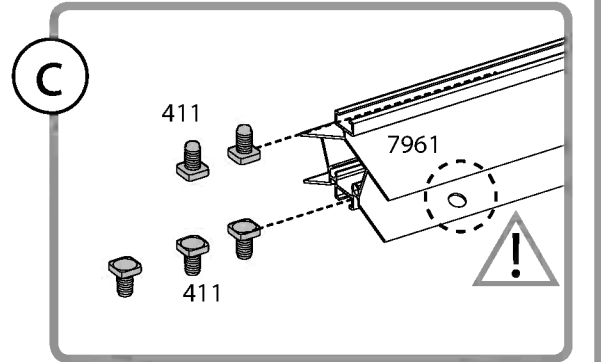
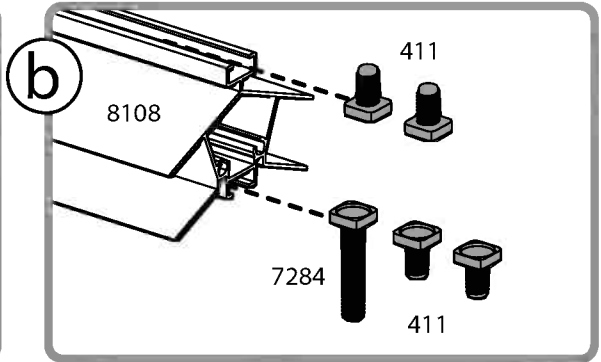
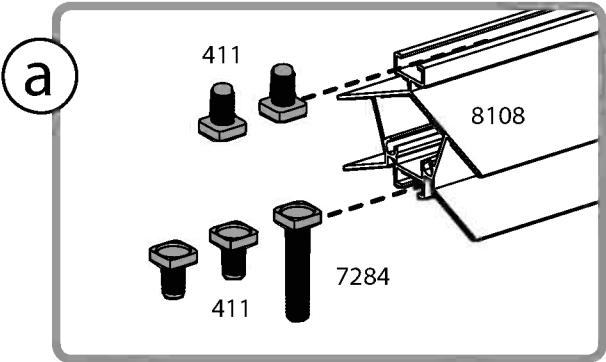
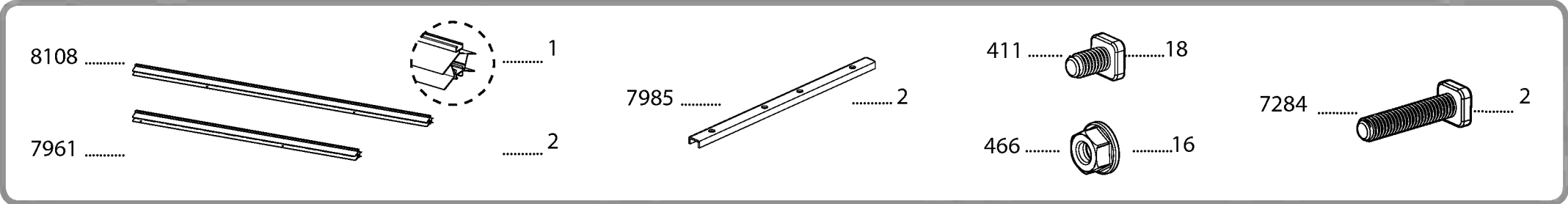

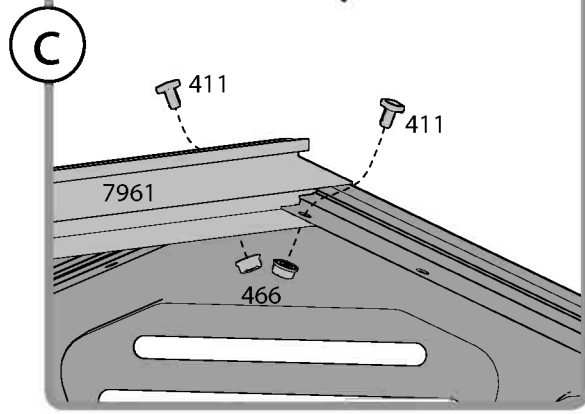
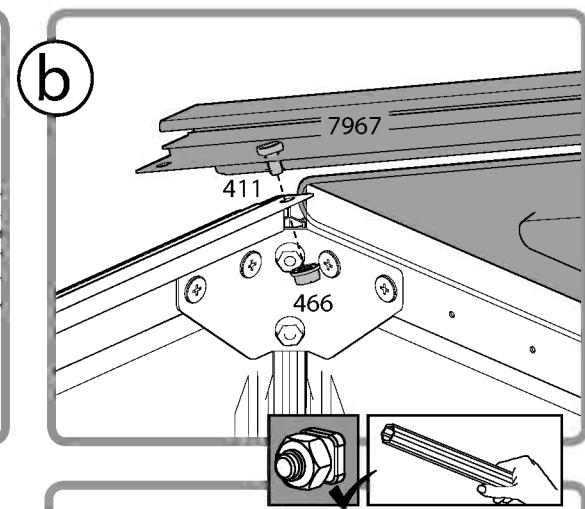
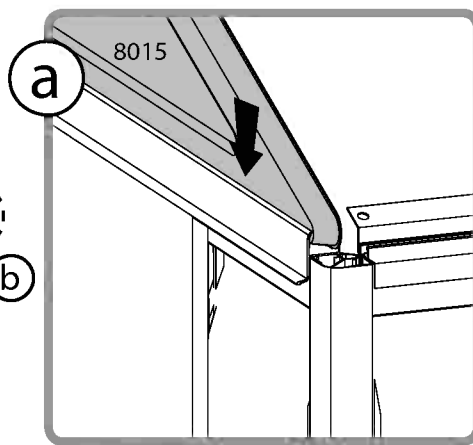
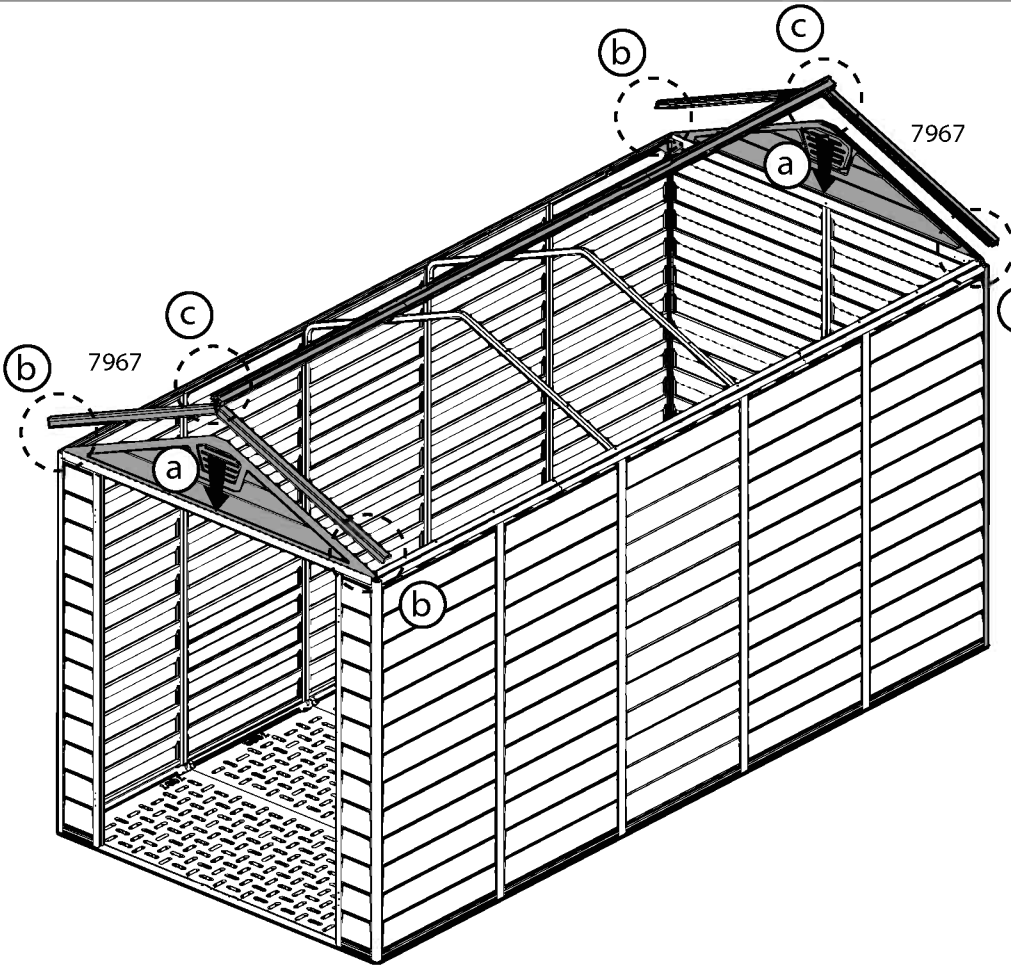
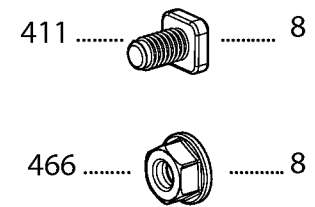
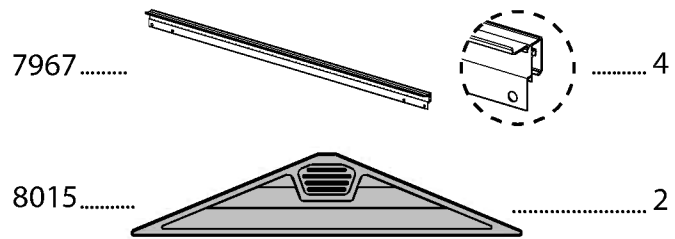
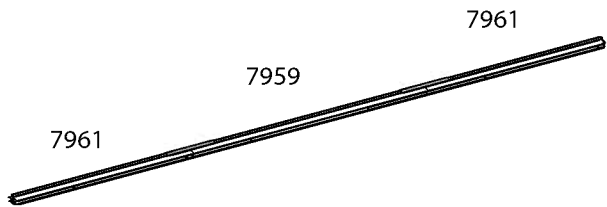



411 16

466 16

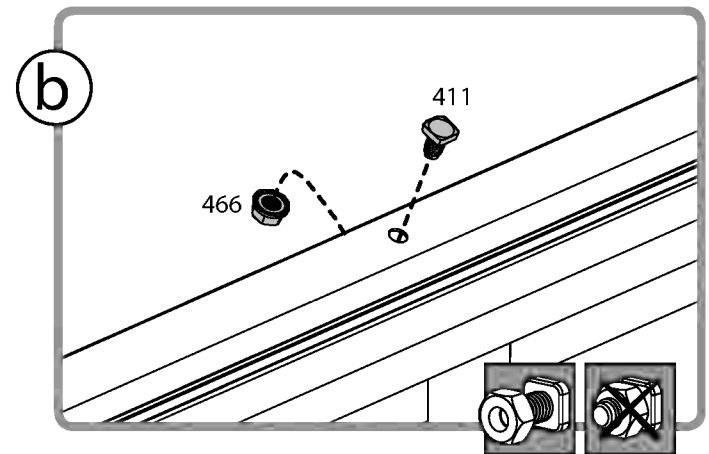
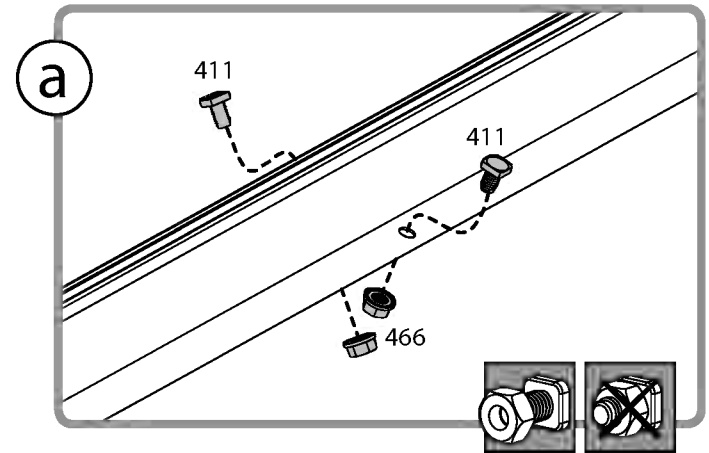
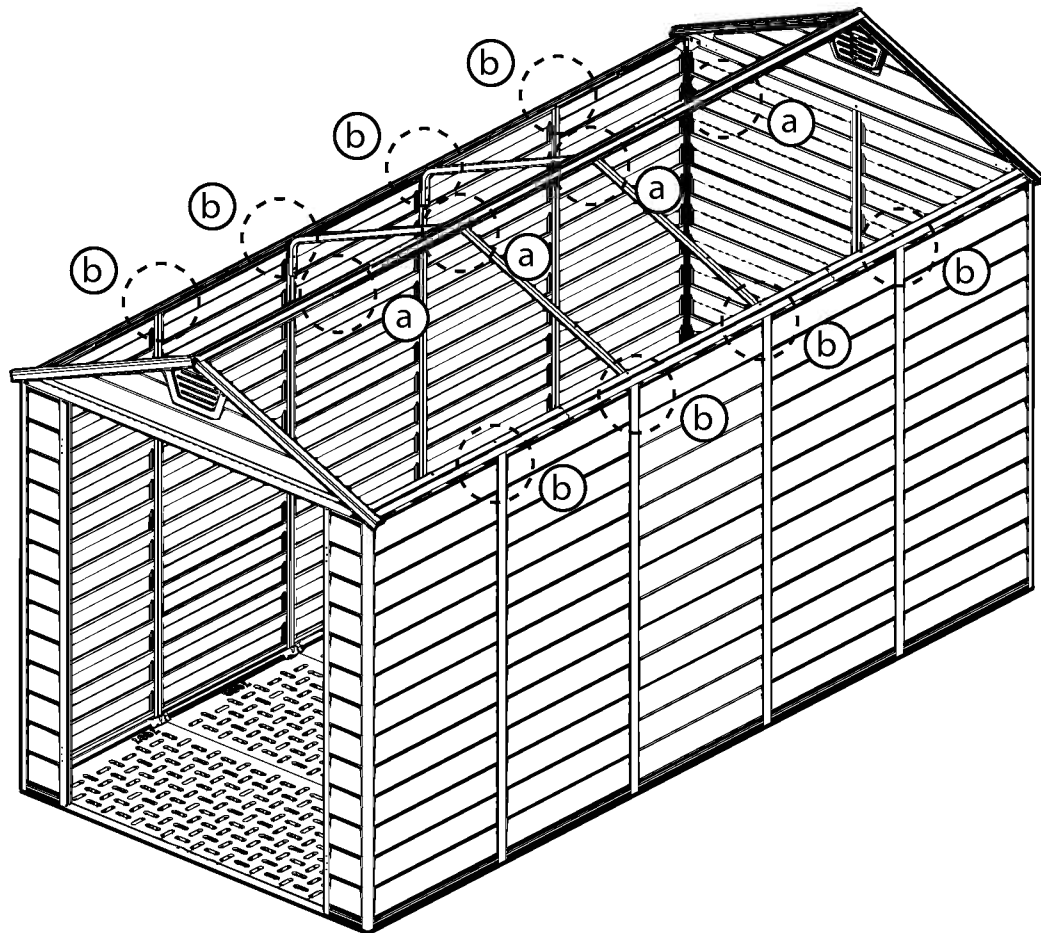

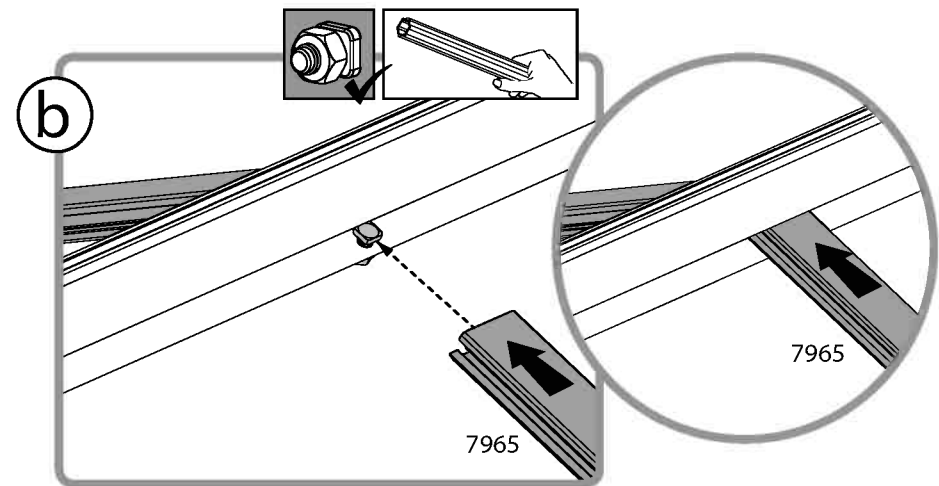
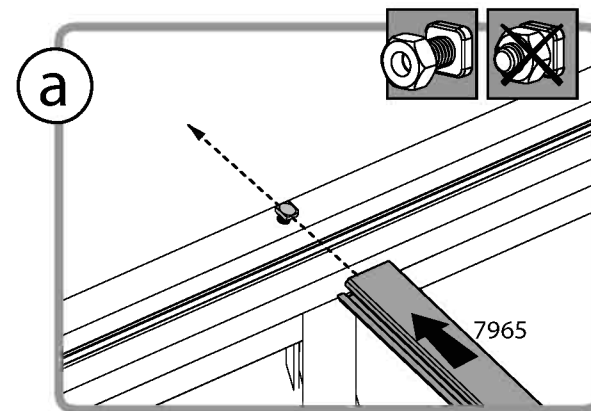
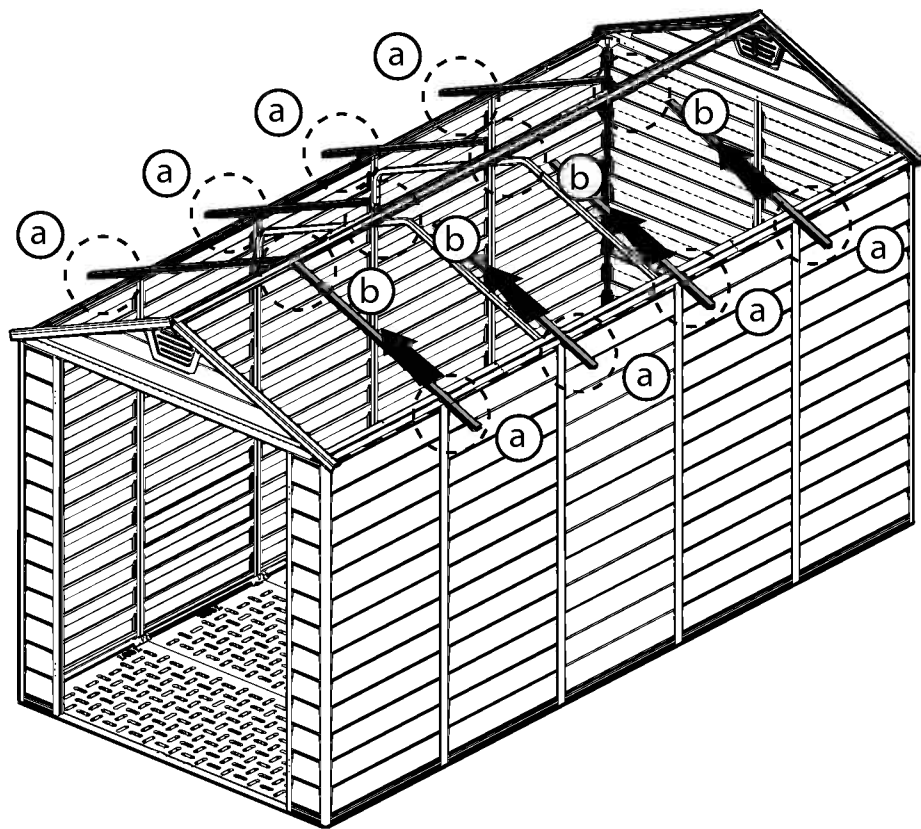

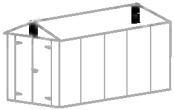

411 1



466 3



8104 2

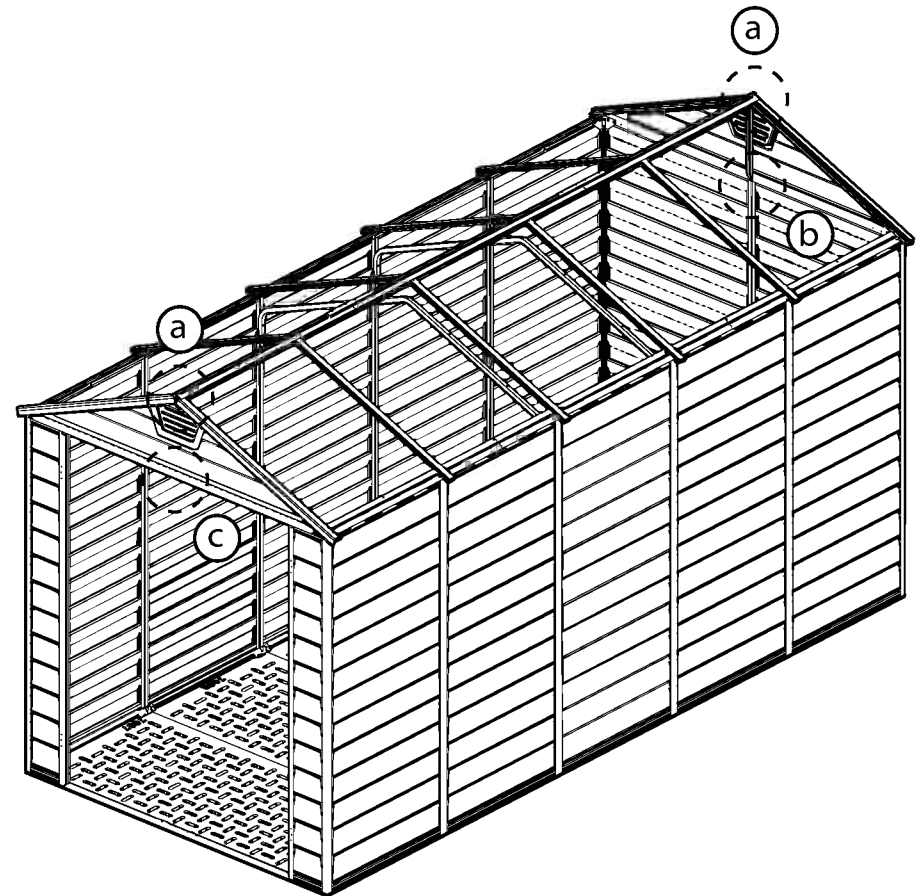
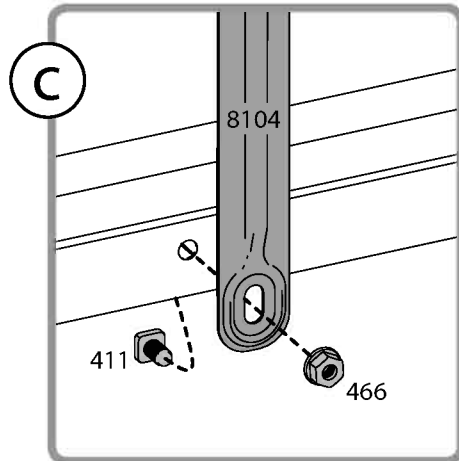
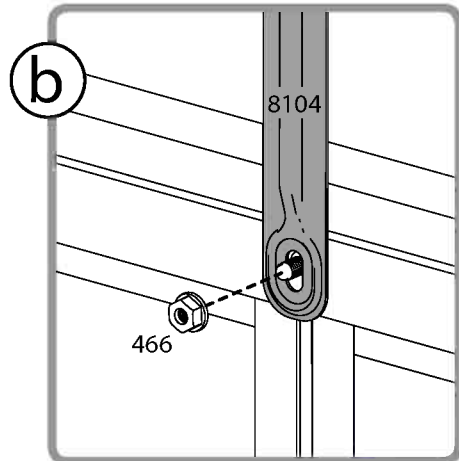
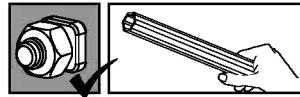
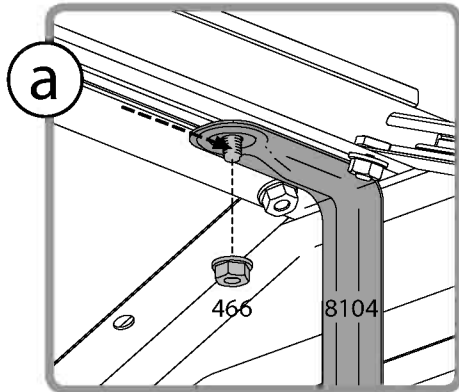
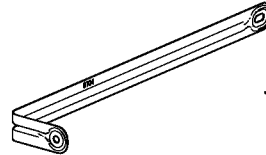



7970	 2	8109	 2	7985	 4	466	 16
7971	 2							411	 16

a

b

c

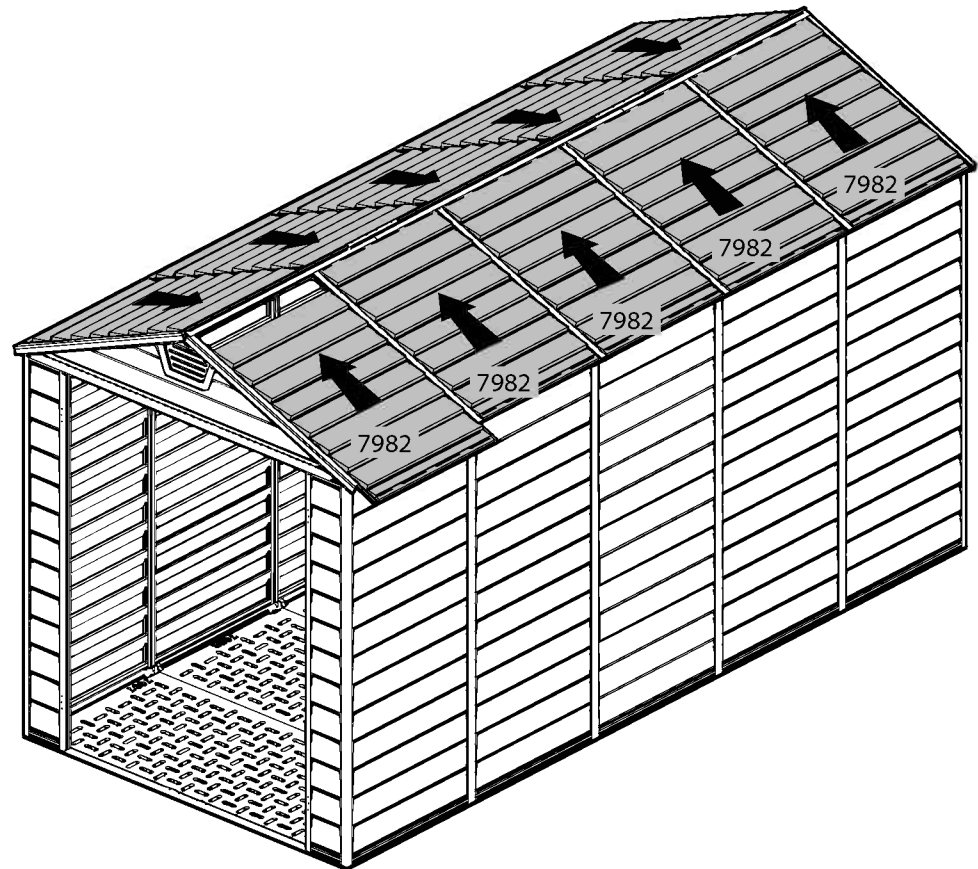
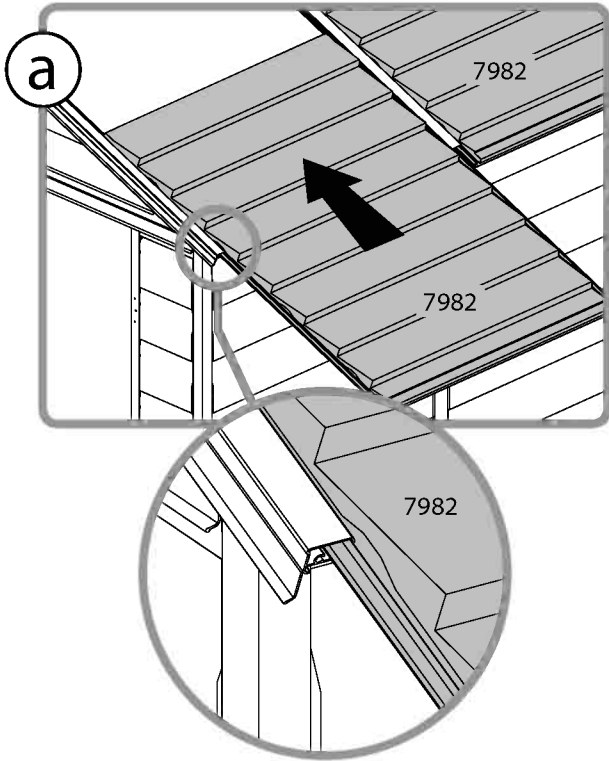
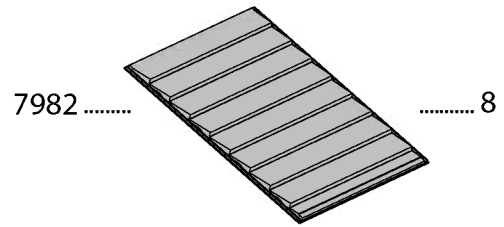

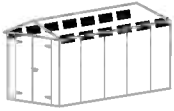

7970
+
7971 2
+
8109



4008 8
Silver



4008 4
Black



7980 2 7981 2

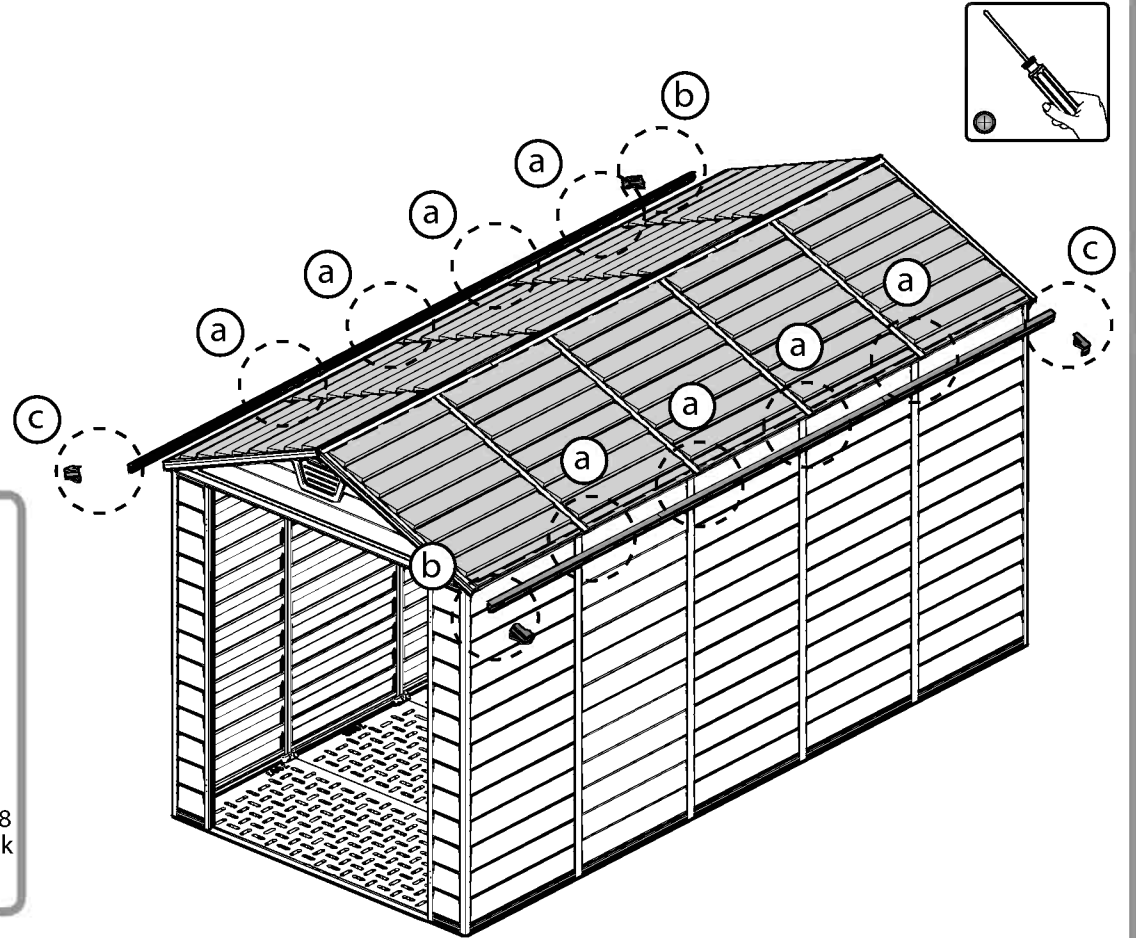
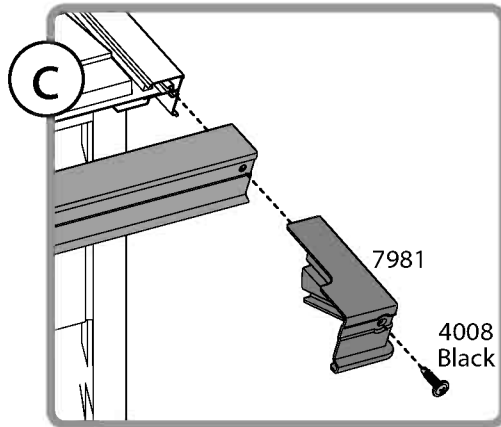
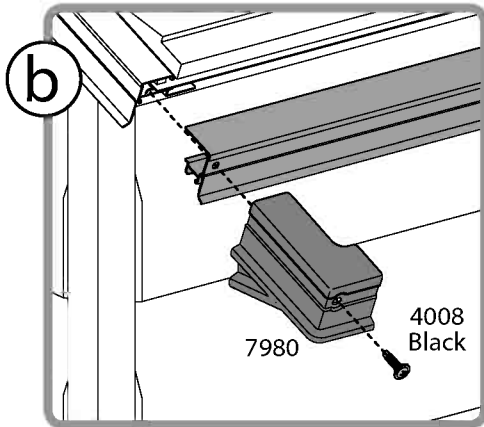
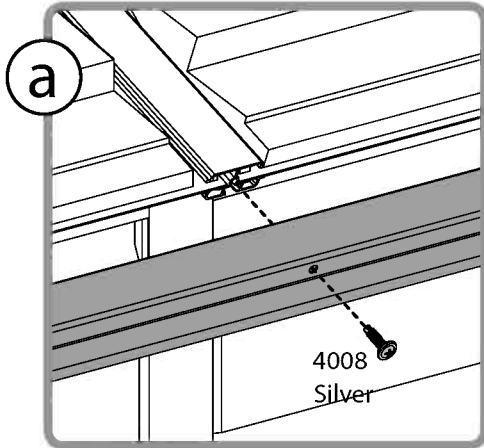
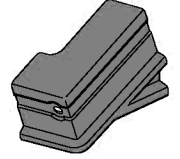
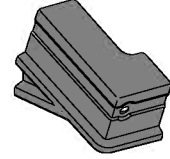

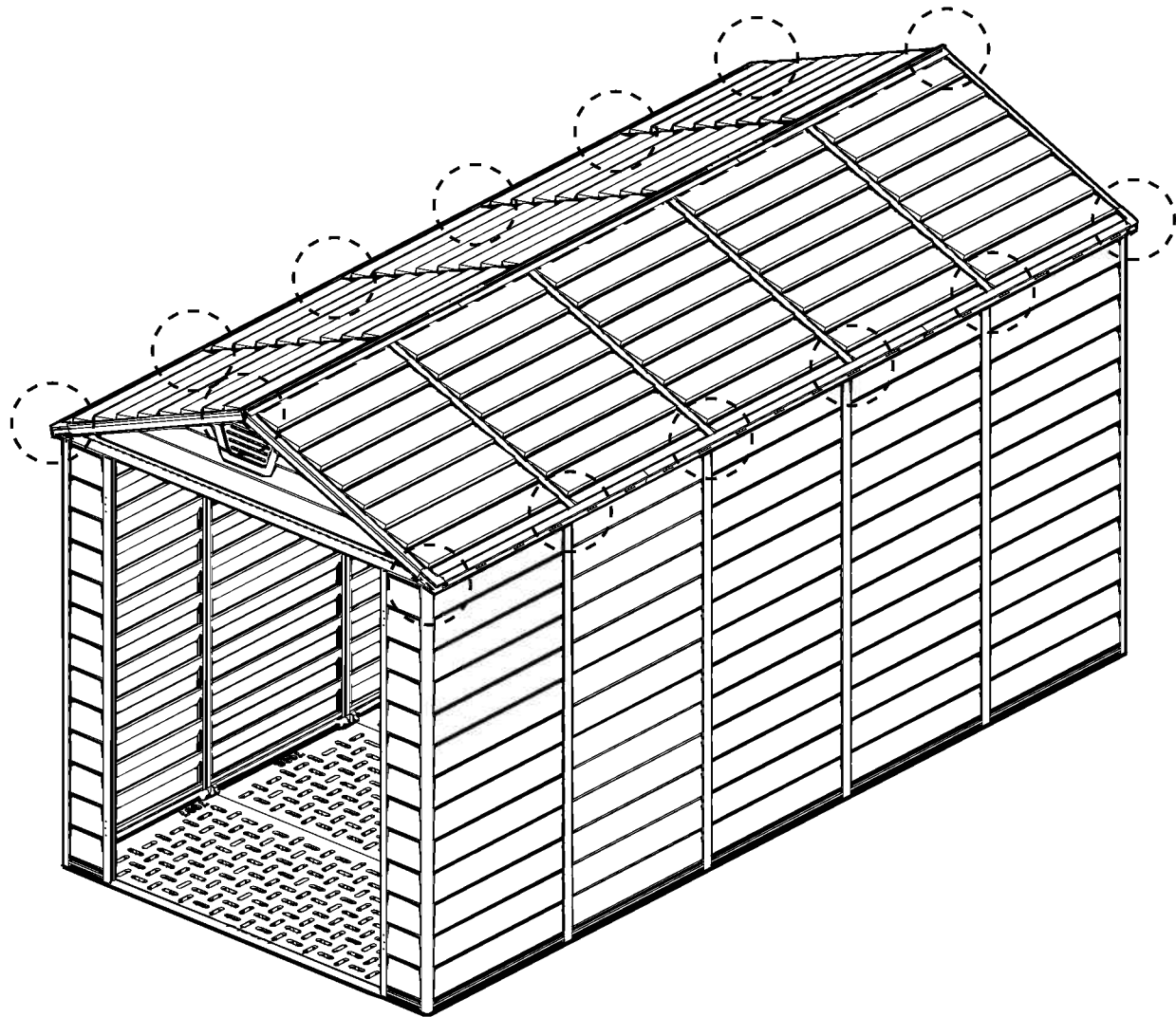
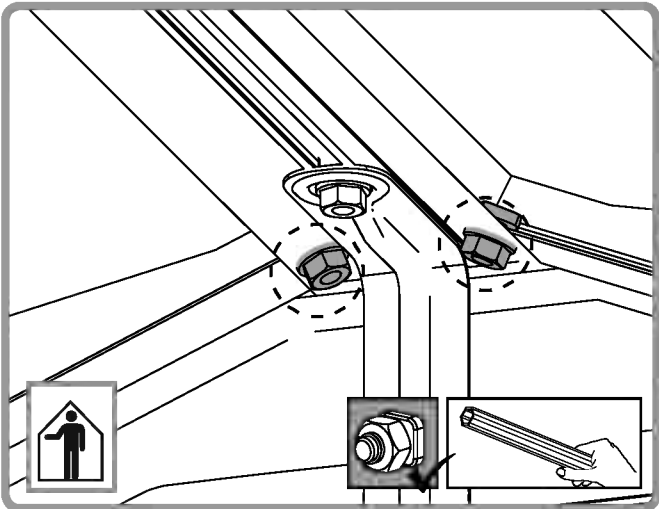
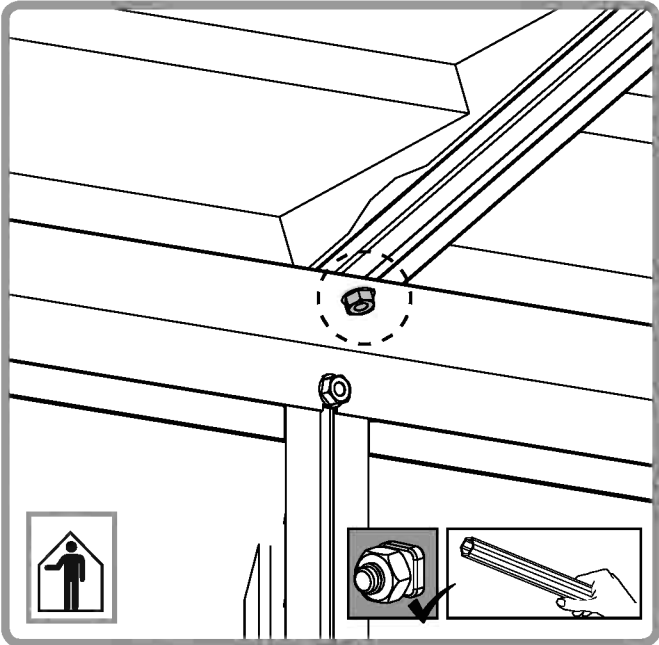

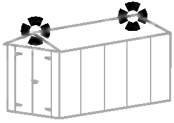

4008 4
Black



7979 2



a

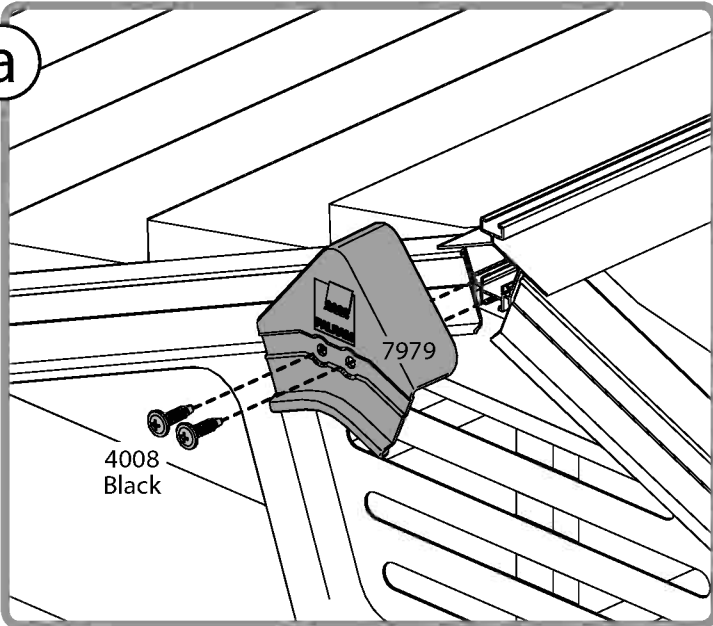

a

a

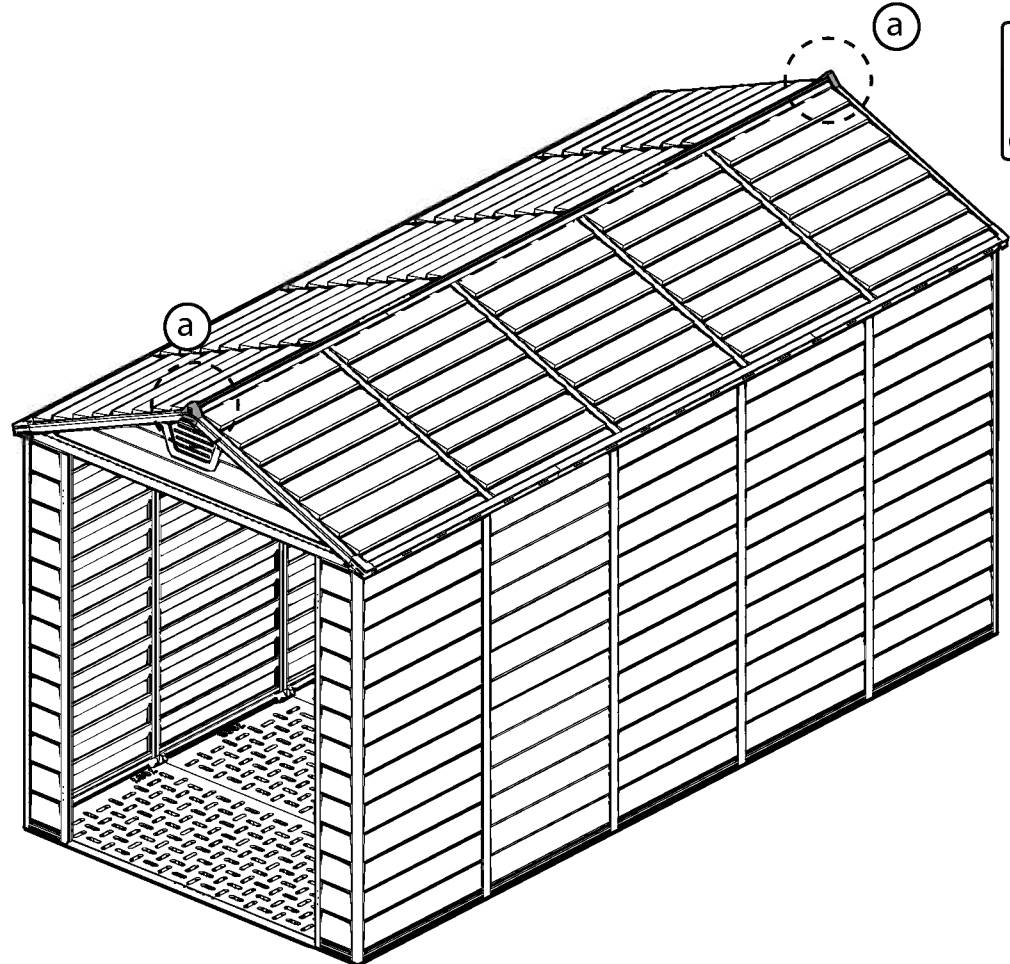

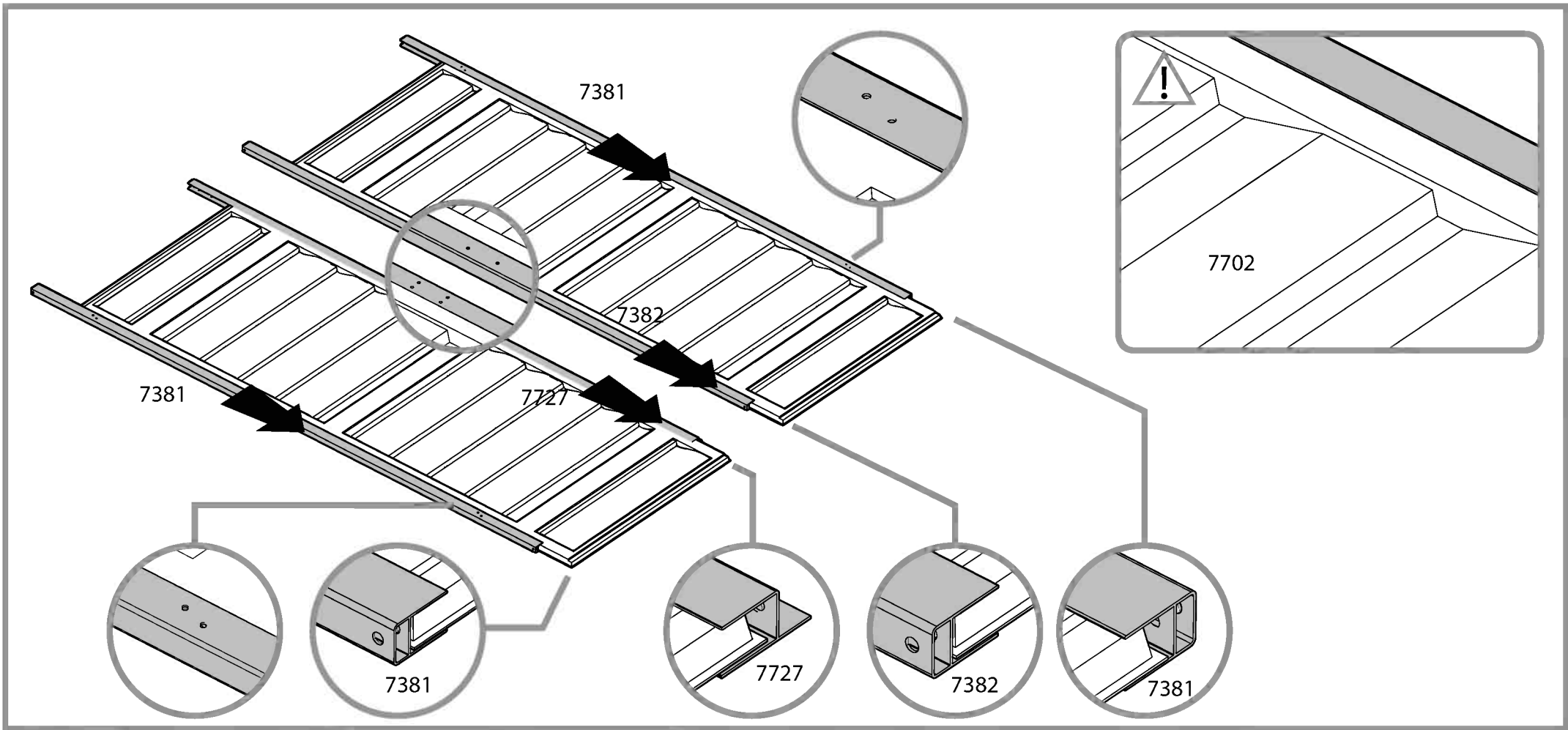
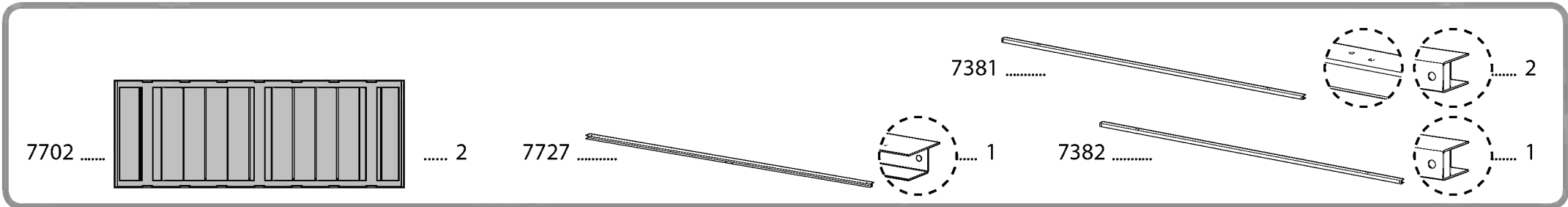
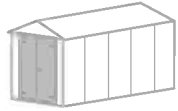

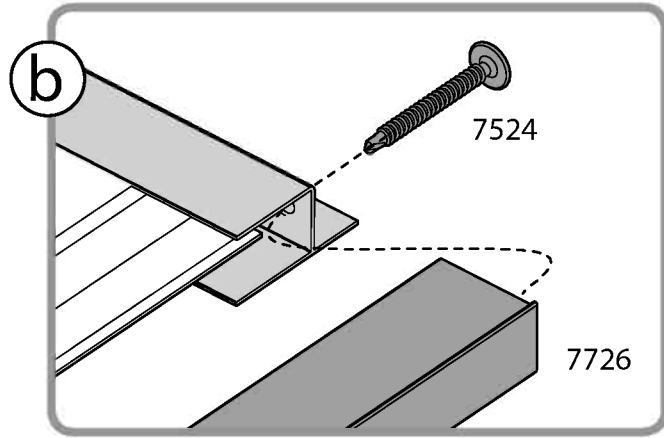
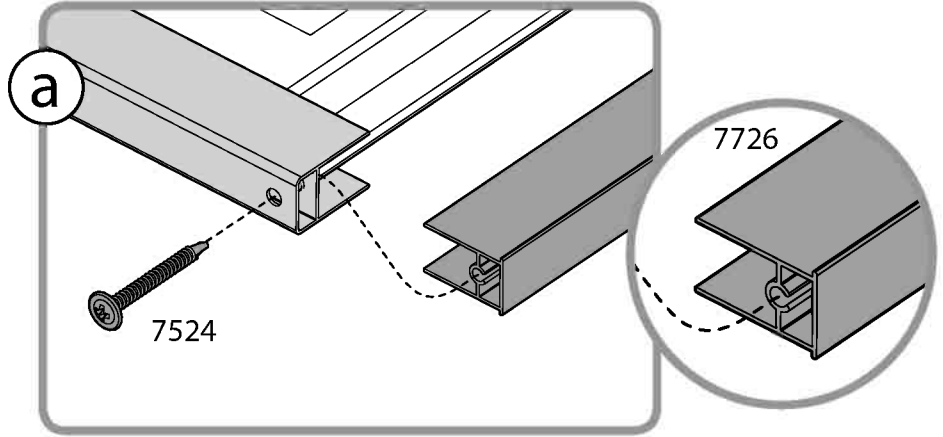
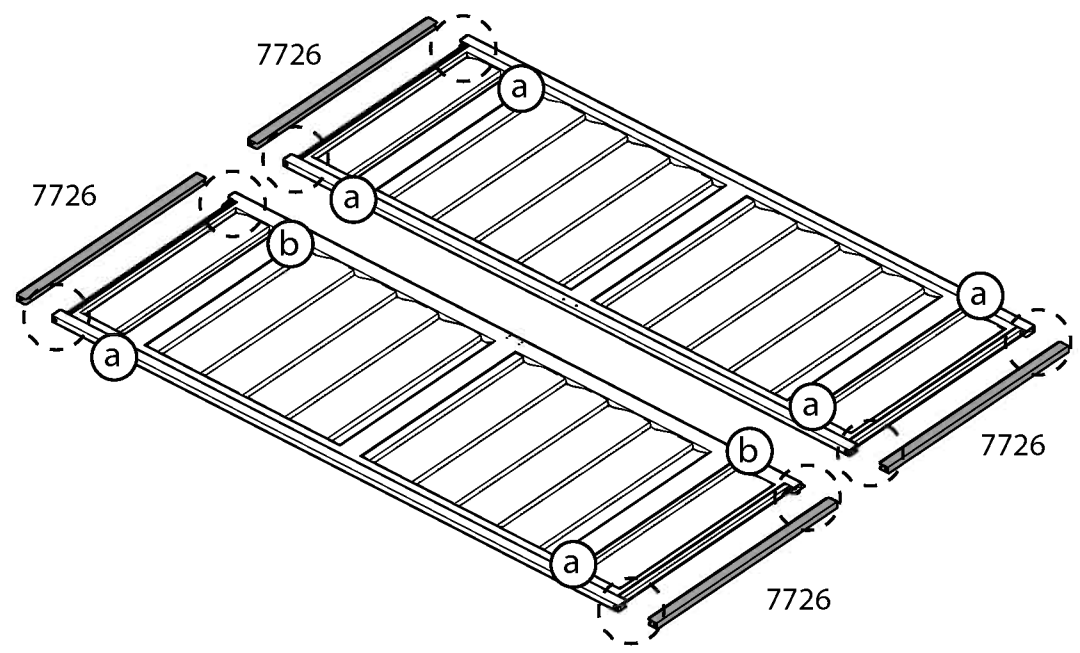
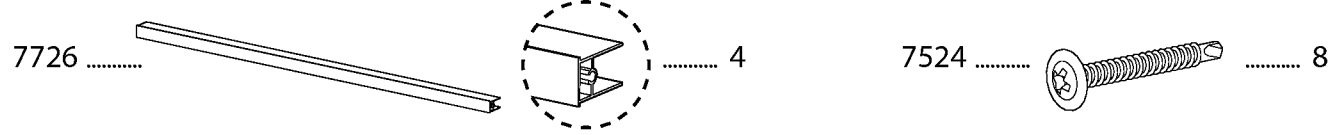
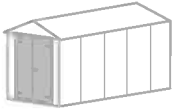

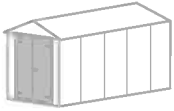

7356 4

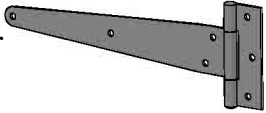

7444 8



428 8



431 8



422 8

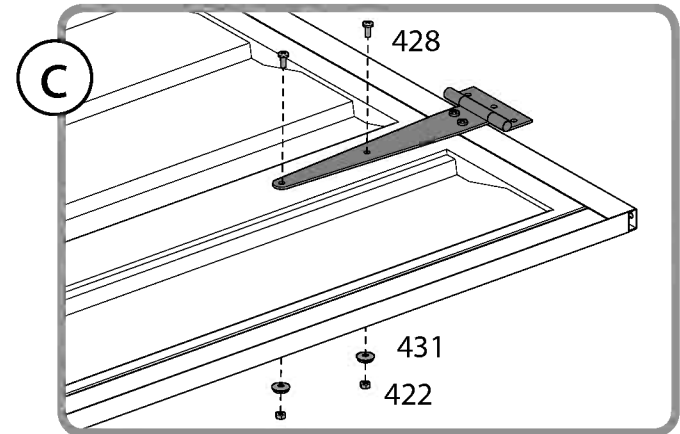
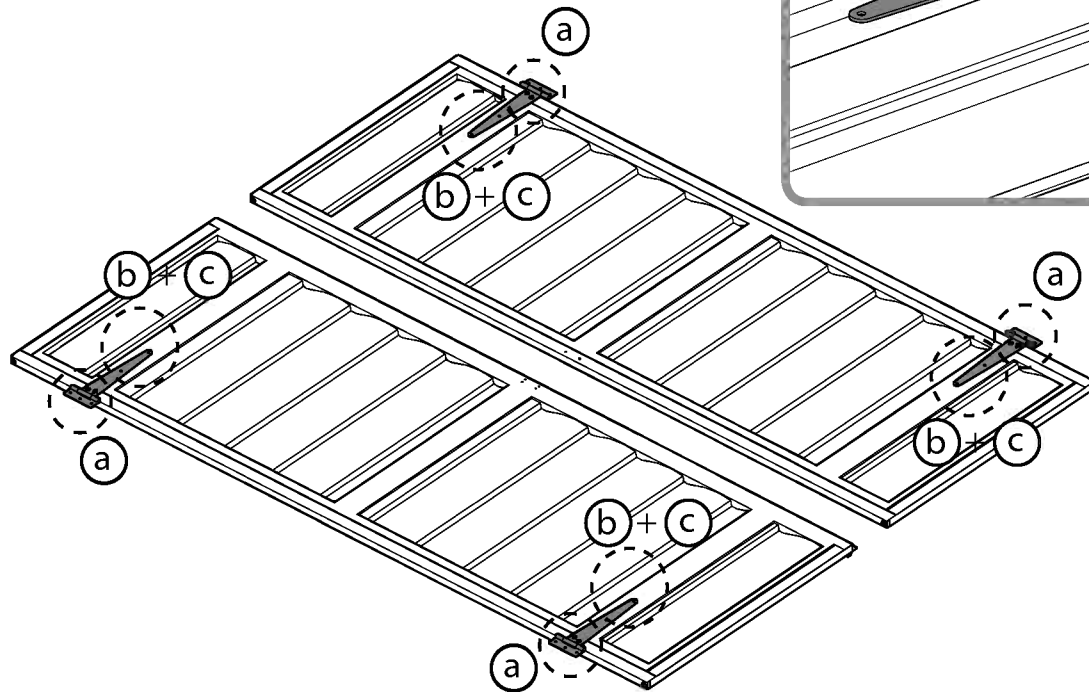
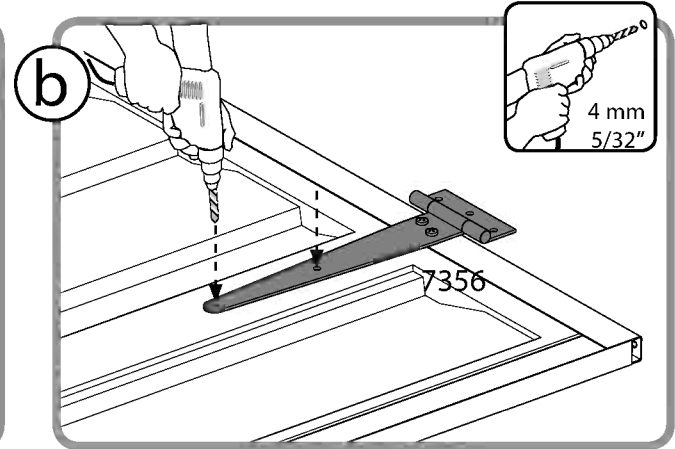
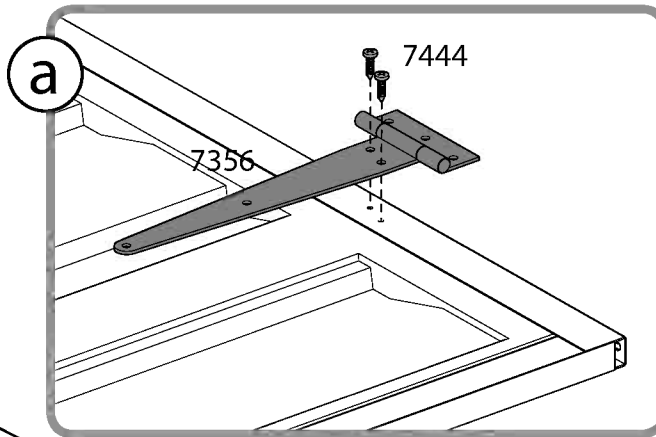
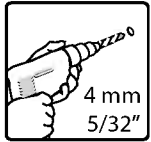
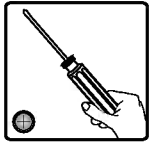

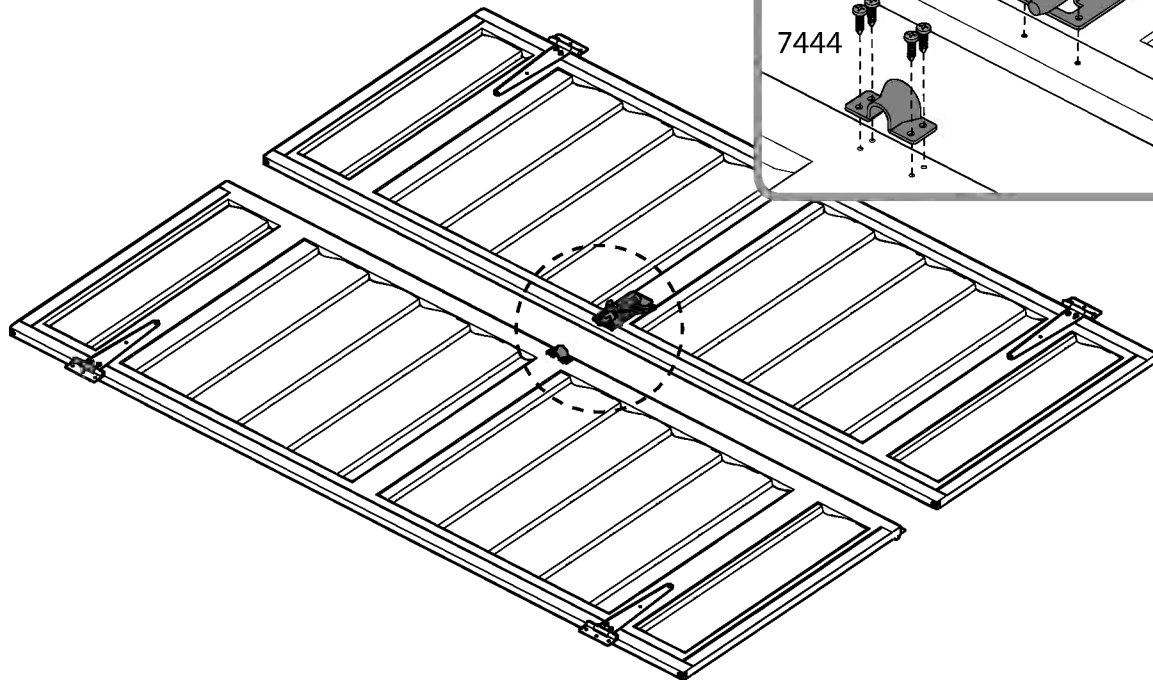
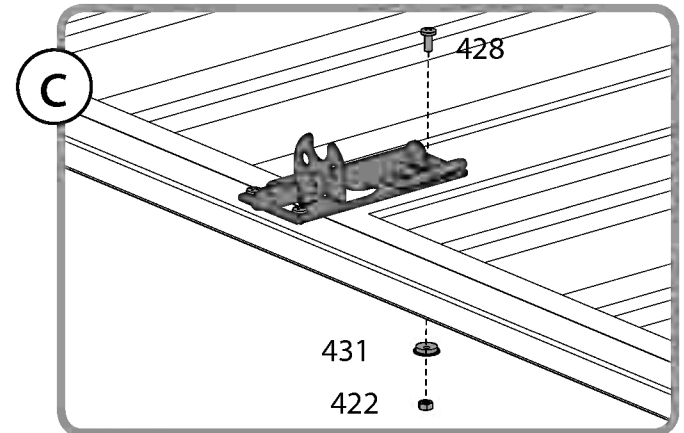
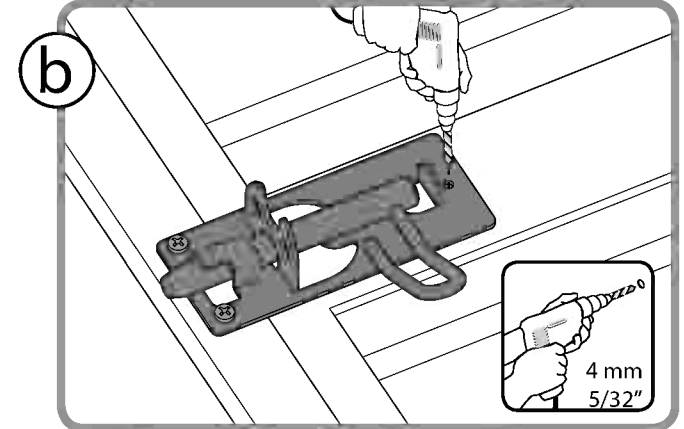
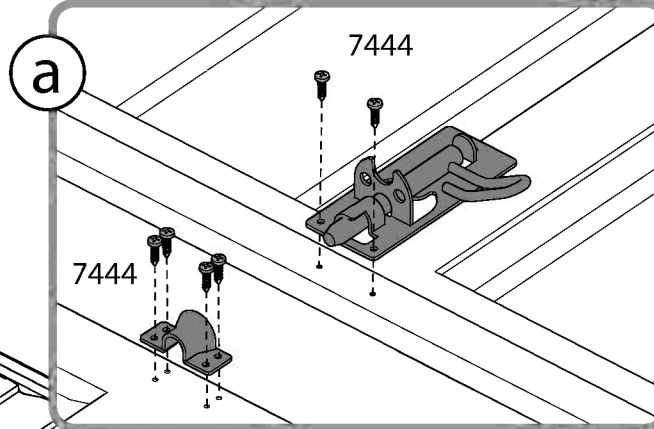
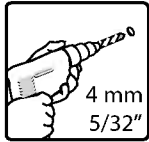
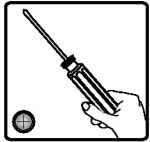
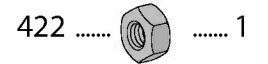
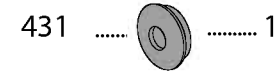
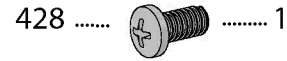
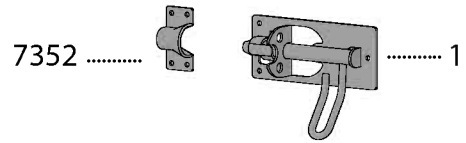
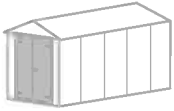

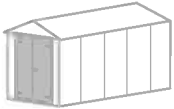

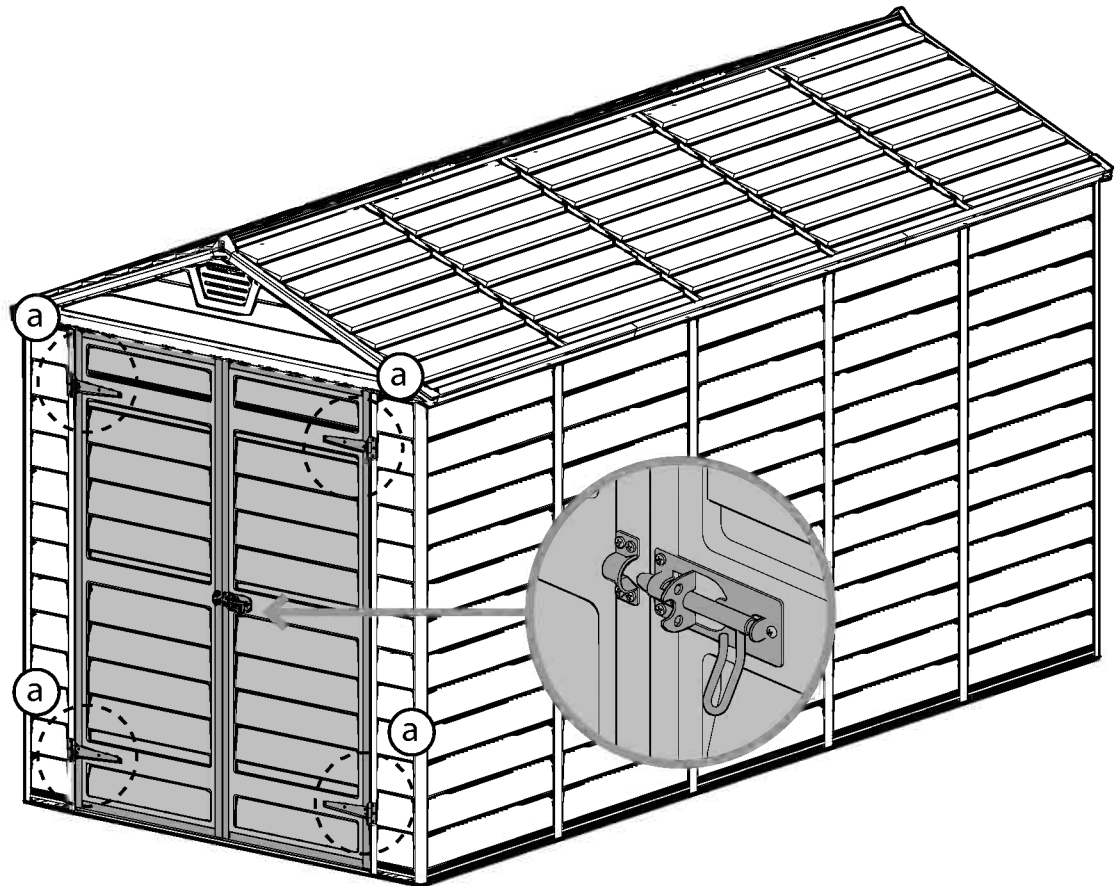
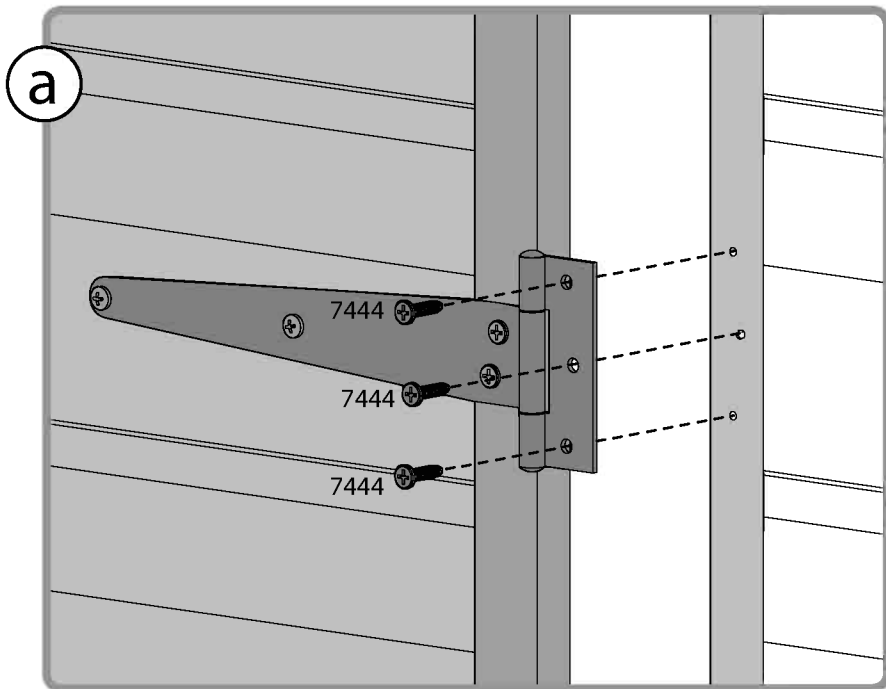
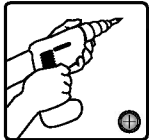

7444
.....12

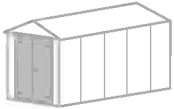

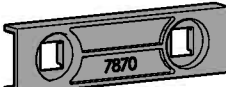
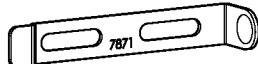

7870  2 7871  2 7442  4

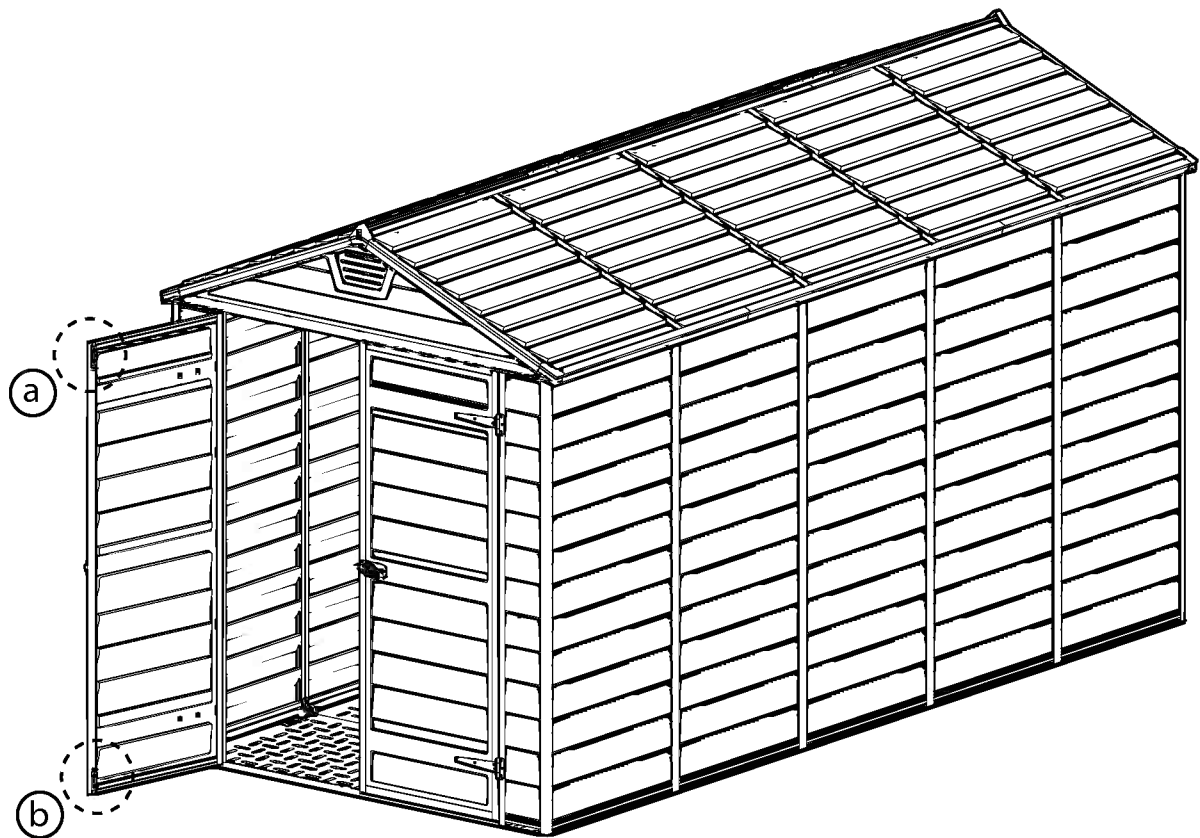
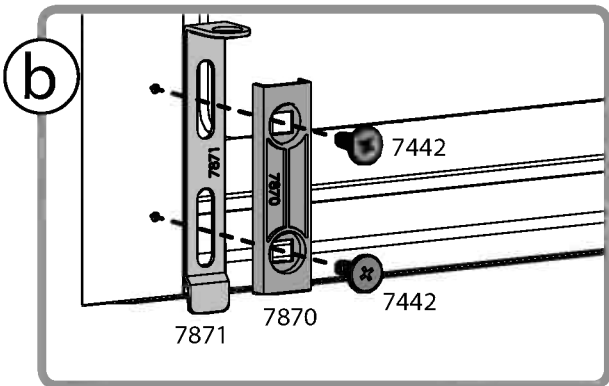
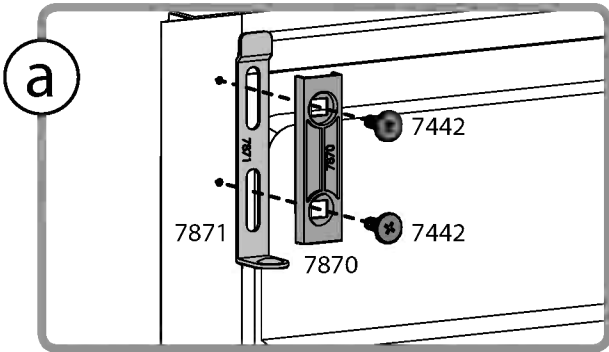
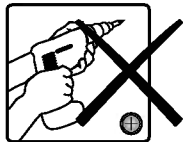
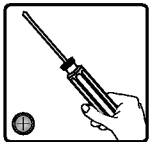



466  2 4020  2

