

Fahrradträger Bike Lift

Bicycle carrier Bike Lift

Porte-vélo Bike Lift

Portabicicletta Bike Lift

Fietsendrager Bike Lift

Nosič jízdních kol Bike Lift

Manual de instrucciones Bike Lift

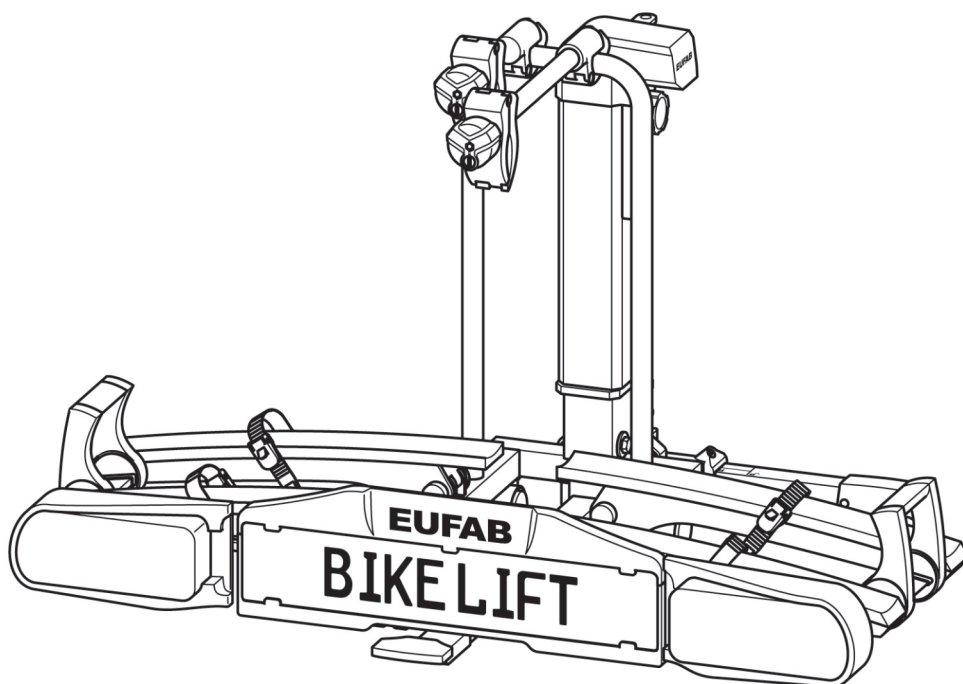

DE	Bedienungsanleitung.....	2
GB	Operating instructions.....	25
F	Manuel de l'opérateur.....	49
I	Istruzioni per l'uso.....	73
NL	Gebruiksaanwijzing.....	97
CZ	Návod k obsluze.....	121
ES	Manual de instrucciones.....	145

Bike Lift
Artikel-Nr. 11535

Inhalt

Angaben zu dieser Gebrauchsanleitung	3
Vorwort.....	3
Pflichten im Umgang mit dieser Gebrauchsanleitung.....	3
Bestimmungsgemäßer Gebrauch	3
Erläuterung zu den Sicherheitshinweisen	3
Lieferumfang	4
Technische Daten	4
Kupplungsvoraussetzungen	4
Sicherheitshinweise	5
Vor der ersten Inbetriebnahme	6
Montage des Kennzeichens am Fahrradträger.....	6
Montage und Benutzung	7
Montage des Fahrradträgers an der Anhängerkupplung.....	7
Heben des Fahrradträgers per Hand auf die Anhängerkupplung.....	8
Heben des Fahrradträgers per eingebautem Motor auf die Anhängerkupplung.....	9
Fahrradträger absenken und anheben	12
Absenken des Fahrradträgers.....	12
Anheben und Sichern des Fahrradträgers.....	13
Fahrräder befestigen	14
Fahrradträger kippen, Zugang zum Kofferraum	18
Demontage des Fahrradträgers	19
Tragen und Verstauen	20
Reinigung und Pflege	20
Wartung	21
Entsorgung	21
Kontakt	21
Anhang	22
Übersicht Ersatzteile (Explosionszeichnung).....	22
Übersicht Ersatzteile (Tabelle).....	23
Steckerbelegung, 13 Pin.....	24

Angaben zu dieser Gebrauchsanleitung

Vorwort

Diese Gebrauchsanleitung hilft Ihnen bei dem

- bestimmungsgemäßen und
- sicheren

Gebrauch des Fahrradträgers Bike Lift.

Pflichten im Umgang mit dieser Gebrauchsanleitung

Jede Person, die diesen Fahrradträger

- montiert,
- reinigt oder
- entsorgt,

muss den vollständigen Inhalt dieser Gebrauchsanleitung zur Kenntnis genommen und verstanden haben.

Bewahren Sie diese Gebrauchsanleitung immer griffbereit und sicher auf. Bei einer Weitergabe des Fahrradträgers geben Sie die Gebrauchsanleitung mit.

Bestimmungsgemäßer Gebrauch

Der Fahrradträger Bike Lift dient dem Transport von max. zwei Fahrrädern. Er darf ausschließlich an Anhängerkupplungen montiert werden, die die Voraussetzungen erfüllen, die im Kapitel Kupplungsvoraussetzungen genannt sind.

Außerdem darf auf keinen Fall die zulässige Nutzlast des Fahrradträgers überschritten werden.

Zum bestimmungsgemäßen Gebrauch gehört auch die Beachtung aller Informationen in dieser Montageanleitung, insbesondere die Beachtung der Sicherheitshinweise. Jede andere Verwendung gilt als nicht bestimmungsgemäß und kann zu Sachschäden oder Personenschäden führen.

Die EAL GmbH übernimmt keine Haftung für Schäden, die durch nicht bestimmungsgemäßen Gebrauch entstehen.

Erläuterung zu den Sicherheitshinweisen

In der Anleitung finden Sie folgende Kategorien von Sicherheitshinweisen:



GEFAHR

Hinweise mit dem Signalwort GEFAHR warnen vor einer Gefährdung mit hohem Risikograd.

Wenn sie nicht gemieden wird, hat sie den Tod oder schwere Verletzungen zur Folge.



WARNUNG

Hinweise mit dem Signalwort WARNUNG warnen vor einer drohenden Gefährdung mit mittlerem Risikograd.

Wenn sie nicht gemieden wird, können Tod oder schwere Verletzungen die Folge sein.



VORSICHT

Hinweise mit dem Signalwort VORSICHT warnen vor einer drohenden Gefährdung mit niedrigem Risikograd.

Wenn sie nicht gemieden wird, können geringfügige oder mäßige Verletzungen die Folge sein.



ACHTUNG!

Hinweise mit dem Wort ACHTUNG warnen vor einer Gefährdung mit einem drohenden Sachschaden.

Wenn sie nicht gemieden wird, kann das Produkt oder etwas in der Umgebung beschädigt werden.



HINWEIS

Sonstige Hinweise:

Nützlicher Tipp. Erleichtert die Bedienung oder Montage des Produkts oder dient zum besseren Verständnis.

Das jeweils verwendete Sicherheitssymbol ersetzt nicht den Text des Sicherheitshinweises.

Lesen Sie deshalb den Sicherheitshinweis und befolgen Sie ihn genau!

Lieferumfang

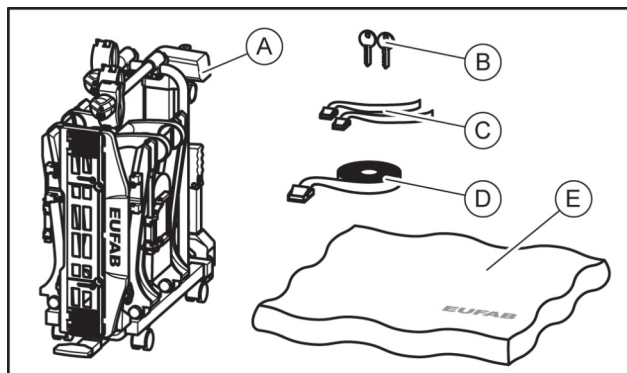

- A = Fahrradträger
- B = 2 Schlüssel
- C = 2 Sicherheitsgurte für Vorderräder
- D = 1 Sicherheitsgurt für Fahrradrahmen
- E = Schutzhülle

Technische Daten

Material:	Aluminium Stahl Kunststoff
Eigengewicht:	25 kg
Nutzlast, max.:	60 kg
Stromverbrauch, durchschnittlich:	2 A
Stromverbrauch, maximal:	5,5 A
Abmessungen (BxHxT), minimal:	30 × 74 × 74 cm
Abmessungen (BxHxT), maximal:	135 × 74 × 74 cm
Verpackungsgröße (BxHxT):	81 × 77 × 33 cm

Die max. Nutzlast des Fahrradträgers sowie die zulässige Stützlast der Anhängerkupplung dürfen nicht überschritten werden.

Das zulässige Gesamtgewicht, sowie die zulässige Achslast des Fahrzeuges darf durch Fahrradträger und Ladung nicht überschritten werden.

Beispiele für Bike Lift

max. Stützlast Anhängerkupplung	Eigengewicht Fahrradträger	max. Nutzlast am Fahrradträger
50 kg	25 kg	25 kg
60 kg	25 kg	35 kg
75 kg	25 kg	50 kg
90 kg	25 kg	max. 60 kg !

Kupplungsvoraussetzungen



GEFAHR

Personenschäden durch Brechen der Anhängerkupplung möglich.

Durch Montage des Fahrradträgers an einer Kupplung aus zu weichem Material könnte die Kupplung brechen.

- ⇒ Montieren Sie den Fahrradträger nur an eine Kupplung aus Stahl St52, Grauguss GG52 oder besserer Güte.
- ⇒ Montieren Sie den Träger nie an einer Kupplung aus Aluminium, anderen Leichtmetallen oder Kunststoff.

Kupplungsvoraussetzungen

Montieren Sie den Fahrradträger nur an Anhängerkupplungen, die folgende Eigenschaften besitzen:

Material:..... mind. Stahl St52 oder Grauguss GG52

D-Wert:..... ≥ 7,6 kN

Beachten Sie die Hinweise des Kupplungsherstellers.

Sicherheitshinweise

Befolgen Sie die Montageanweisung genau. Wenn Sie die Anweisungen nicht befolgen, kann das zu Personen- und Sachschäden führen.

Sollten Sie sich bei der Montage nicht sicher sein, bitten Sie Ihren Händler oder den Hersteller um weitere Informationen.

Weder Hersteller noch Händler haften für Schäden, die auf einen unsachgemäßen Gebrauch oder eine unsachgemäße Montage zurückzuführen sind.

Kontrollieren Sie den Fahrradträger und die dazu gehörende Ladung regelmäßig! Sie sind dazu verpflichtet und werden im Schadenfall haftbar gemacht.



HINWEIS

Für diesen Fahrradträger besteht eine europäische Betriebsgenehmigung. Sie ist diesem Träger beigelegt und muss bei Gebrauch des Trägers mitgeführt werden.



HINWEIS

Beim Fahren mit montiertem Fahrradträger gelten die gesetzlichen Bestimmungen und Vorschriften über die Beförderung von Gütern hinter Ihrem Fahrzeug.



WARNUNG

Das Fahren mit dem Fahrradträger beeinflusst die Fahreigenschaften Ihres Fahrzeugs.

Personen- oder Sachschaden durch verändertes Fahrzeugverhalten.

- ⇒ Passen Sie Ihre Fahrgeschwindigkeit dem neuen Fahrzeugverhalten an.
- ⇒ Fahren Sie nie schneller als 130 km/h.
- ⇒ Vermeiden Sie plötzliche und ruckartige Steuerbewegungen.
- ⇒ Achten Sie darauf, dass Ihr Fahrzeug länger ist als gewohnt.



WARNUNG

Über den Rand des Fahrzeugs bzw. Fahrradträgers stehende Teile können während der Fahrt Personen- oder Sachschäden verursachen.

Personen- oder Sachschaden durch überstehende Teile.

- ⇒ Montieren Sie nur Teile, die nicht über den Rand des Fahrzeugs herausragen.



WARNUNG

Das Überschreiten der max. Nutzlast des Fahrradträgers, sowie der zulässigen Stützlast der Anhängerkupplung oder des zulässigen Gesamtgewichts kann zu schweren Unfällen führen.

Personen- oder Sachschaden durch Überladen.

- ⇒ Beachten Sie unbedingt die Angaben zur max. Nutzlast, zulässigen Stützlast und zulässigem Gesamtgewicht Ihres Fahrzeugs. Überschreiten Sie diese Angaben keinesfalls.



WARNUNG

Das Fahren ohne Sicherheitsgurte kann zu Unfällen führen.

Personen- oder Sachschaden durch Verlieren der Fahrräder.

- ⇒ Überprüfen Sie vor jedem Fahrtantritt den korrekten und festen Sitz des Gurtes um die Fahrräder und den U-Bügel des Trägers, siehe Kapitel „Fahrräder montieren“.
- ⇒ Überprüfen Sie vor jedem Fahrtantritt den korrekten und festen Sitz der beiden Gurte um das Vorderrad und den Gurt um das Hinterrad des Fahrrades.
- ⇒ Spannen Sie die Gurte ggf. nach.
- ⇒ Überprüfen Sie vor jedem Fahrtantritt, ob die verwendeten Gurte unbeschädigt und unverschlissen sind.
- ⇒ Beschädigte oder verschlissene Gurte müssen vor Fahrtantritt gegen unbeschädigte Gurte ausgetauscht werden. Es dürfen nur Gurte verwendet werden, die von der EAL GmbH dafür zugelassen sind.



WARNUNG

Das Fahren mit zusammengeklapptem Fahrradträger kann zu Unfällen führen. Die beweglichen Teile des Fahrradträgers stellen im nicht fertig montierten Zustand eine Gefahrenquelle dar.

Personen- oder Sachschaden durch nicht komplett montierten Fahrradträger.

- ⇒ Demontieren Sie den Fahrradträger, wenn Sie ihn nicht benötigen.
- ⇒ Fahren Sie niemals mit zusammengeklapptem Fahrradträger.



WARNUNG

Abdeckplanen erhöhen den Luftwiderstand. Sie können sich lösen und umherfliegen, das kann zu schweren Unfällen führen.

Personen- oder Sachschaden durch Abdeckplanen.

⇒ Benutzen Sie keine Planen.



WARNUNG

Der Träger setzt sich nach der Befestigung und einigen gefahrenen Kilometern erst richtig auf die Kupplung.

Personen- oder Sachschaden durch Verlieren des Fahrradträgers.

⇒ Kontrollieren Sie die Befestigung des Trägers auf sicheren Sitz nach einigen Kilometern.

⇒ Führen Sie die Montage bei lockerem Sitz neu durch.



WARNUNG

Das Fahren mit montierten Fahrradträger in unwegsamem Gelände kann zum Abbrechen des Trägers führen.

Personen- oder Sachschaden durch Abbrechen des Fahrradträgers.

⇒ Benutzen Sie den Fahrradträger nicht in unwegsamem Gelände.



ACHTUNG

Die Heckklappe könnte gegen den Fahrradträger schlagen und beschädigt werden.

Sachschaden durch öffnende Heckklappe.

⇒ Elektrische Heckklappen abschalten und manuell betätigen.

⇒ Klappen Sie den Fahrradträger vor dem Öffnen der Heckklappe ab.



ACHTUNG

Es können Schäden am Träger oder den Fahrrädern entstehen, wenn die Auspuffmündung direkt daran grenzt.

Sachschaden durch heiße Auspuffgase.

⇒ Benutzen Sie ggf. eine Auspuffblende.

Vor der ersten Inbetriebnahme Montage des Kennzeichens am Fahrradträger

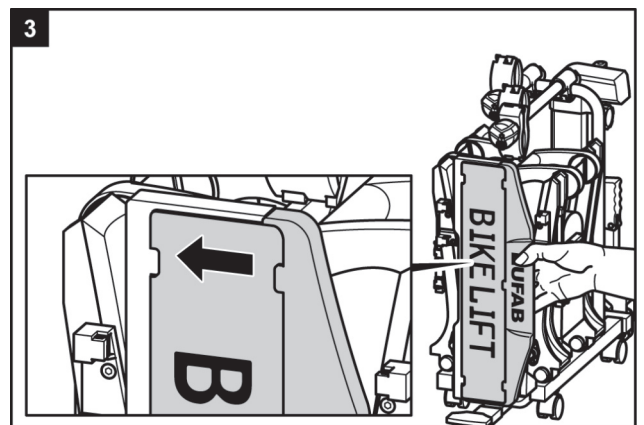
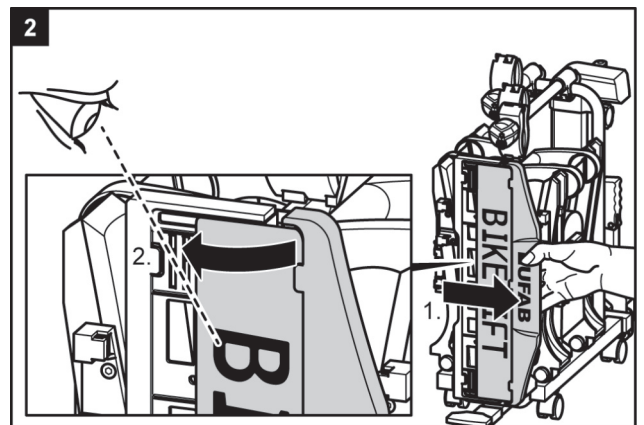
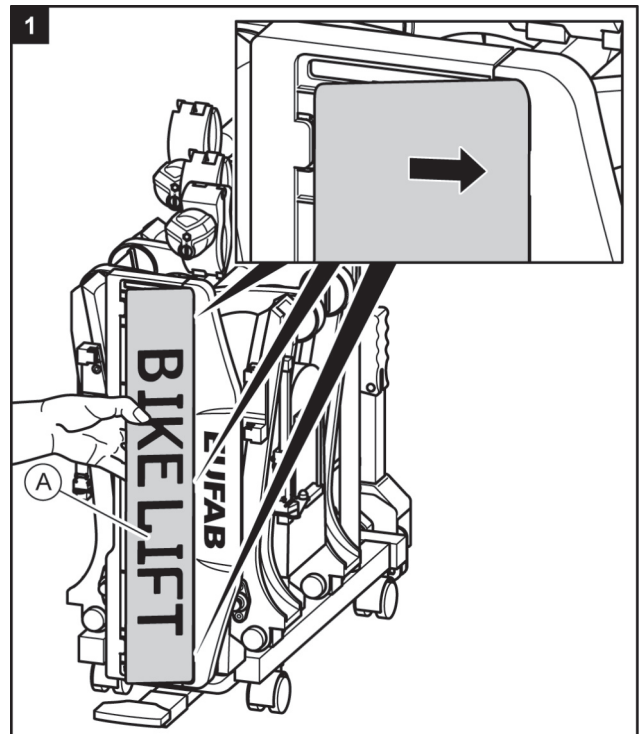

Montage und Benutzung

Montage des Fahrradträgers an der Anhängerkupplung

- ⇒ Stellen Sie Ihr Fahrzeug auf einer ebenen Fläche ab.
- ⇒ Ziehen Sie die Handbremse an.

Verschiedene Montagemöglichkeiten

Sie können den Fahrradträger auf zwei verschiedene Arten an der Anhängerkupplung montieren.

1. Anheben des Fahrradträgers per Hand auf die Anhängerkupplung.
Vorteil: schnelle Montage.
Nachteil: größerer Kraftaufwand nötig als bei der Montage per eingebautem Motor.
⇒ Folgen Sie den Schritten 1 - 6 und 17 - 23 in diesem Kapitel.
2. Heben des Fahrradträgers per eingebautem Motor auf die Anhängerkupplung.
Vorteil: nur minimaler Kraftaufwand nötig
Nachteil: längere Montagezeit gegenüber der manuellen Montage.
⇒ Folgen Sie den Schritten 1 - 2 und 7 - 23 in diesem Kapitel.



WARNUNG

Beschädigungen des Trägers z. B. durch verbogene Teile, Risse oder Kratzer, schließen die sichere Funktion des Trägers aus.

Personen- oder Sachschaden durch beschädigten Fahrradträger.

- ⇒ Montieren Sie den Fahrradträger nicht, wenn Beschädigungen vorhanden sind.
- ⇒ Gehen Sie wie im Kapitel Wartung beschrieben vor.



WARNUNG

Eine unsaubere oder schadhafte Verbindung zwischen Fahrradträger und Anhängerkupplung kann zum Lösen des Fahrradträgers führen.

Personen- oder Sachschaden durch Verlust des Fahrradträgers während der Fahrt.

- ⇒ Tauschen Sie eine schadhafte Anhängerkupplung aus.
- ⇒ Säubern Sie die Anhängerkupplung von Dreck, Staub und Fett.



HINWEIS

Bei Kupplungen befindet sich oft eine Lackschicht auf der Kupplungskugel. Für den bestmöglichen Halt des Fahrradträgers, muss diese Lackschicht vorsichtig entfernt werden. Beachten Sie die Hinweise des Kupplungsherstellers.

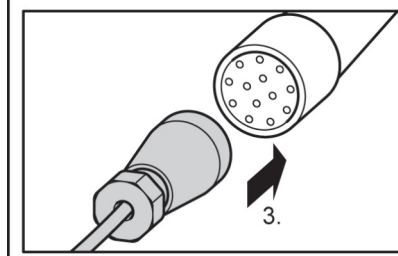
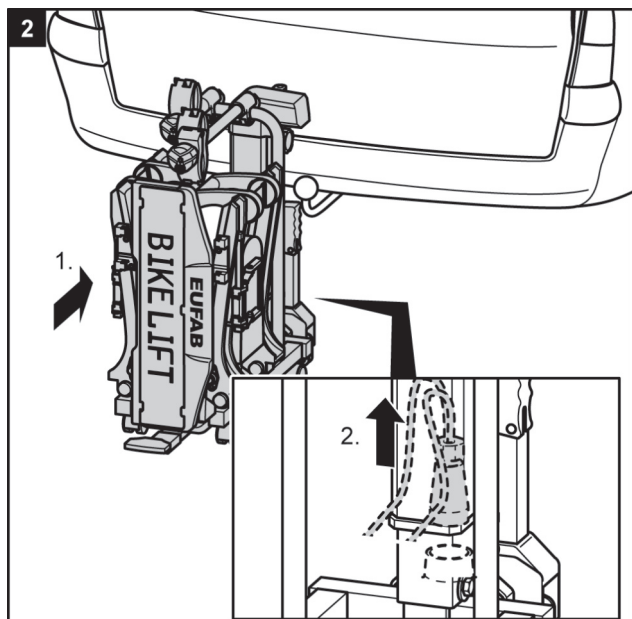
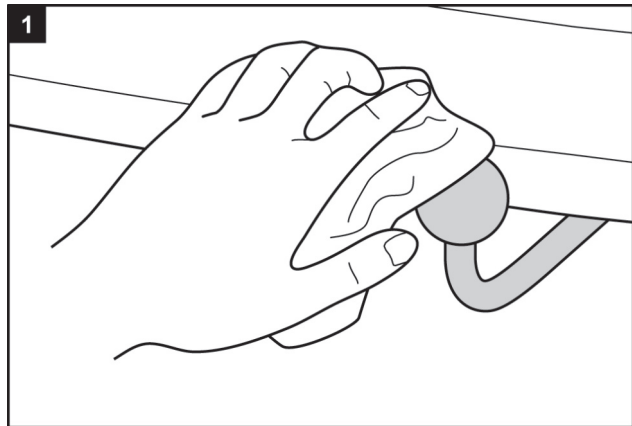

- ⇒ **3** Anheben per Hand, folgen Sie dem nächsten Arbeitsschritt.
- ⇒ **7** Anheben per eingebautem Motor, folgen Sie weiter ab Arbeitsschritt 7.

Heben des Fahrradträgers per Hand auf die Anhängerkupplung.

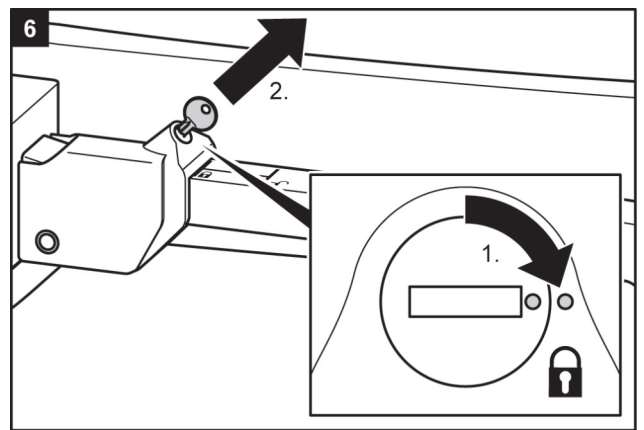
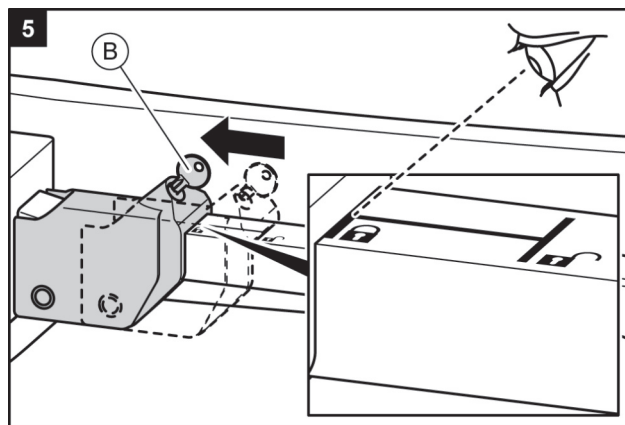
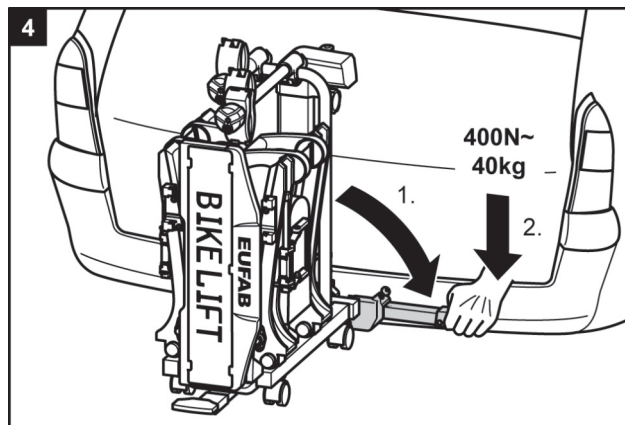
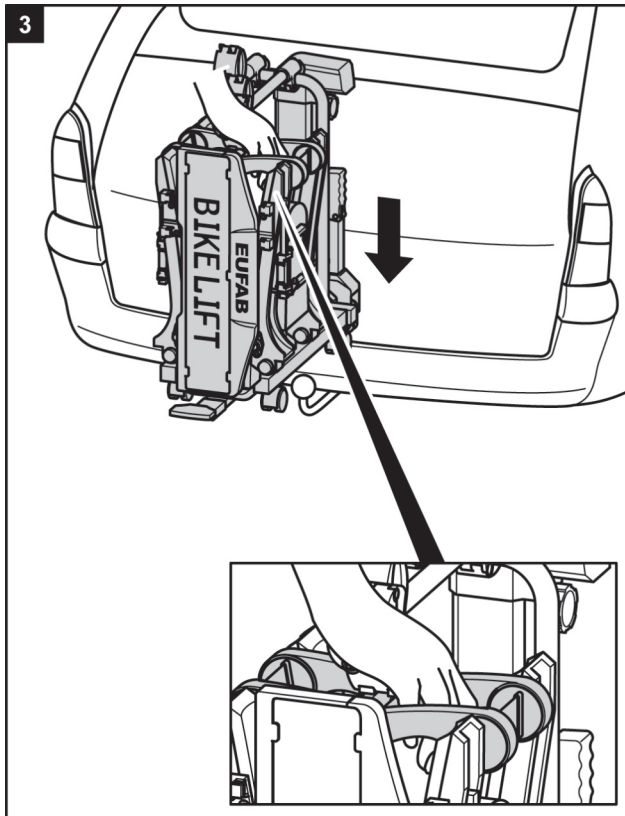

WARNUNG

Wird der Hebel nicht durch Abschließen gesichert, könnte sich der Fahrradträger während der Fahrt vom Fahrzeug lösen.

Personen- oder Sachschaden durch ungesicherten Fahrradträger.

- ⇒ Schließen Sie den Fahrradträger ab.
- ⇒ Prüfen Sie, ob Sie den Hebel abgeschlossen und den Schlüssel abgezogen haben.

Durch das Abschließen beugen Sie auch einem eventuellen Diebstahl des Fahrradträgers vor



WARNUNG

Eine lockere Verbindung zwischen Träger und Anhängerkupplung kann zum Lösen des Fahrradträgers führen.

Personen- oder Sachschaden durch Verlust des Fahrradträgers während der Fahrt.

- ⇒ Prüfen Sie den Fahrradträger auf sichere Befestigung.
- ⇒ Wiederholen Sie bei lockerer Verbindung die Arbeitsschritte 3 bis 6. Sollte sich keine Besserung einstellen, muss evtl. der Schnellverschluss nachgestellt werden, siehe Kapitel Wartung.

⇒ **17** Folgen Sie ab hier Schritt 17 in diesem Kapitel.

Heben des Fahrradträgers per eingebautem Motor auf die Anhängerkupplung

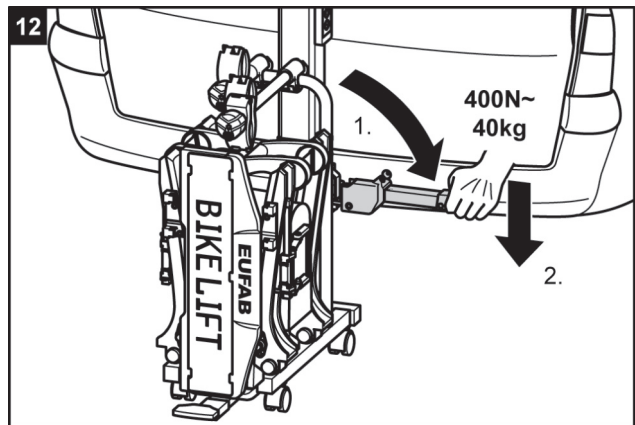
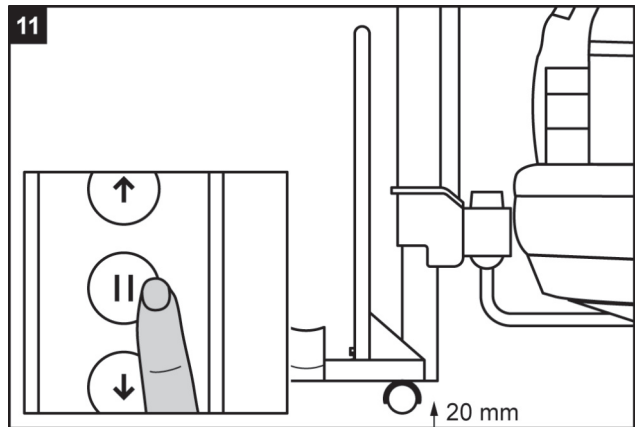
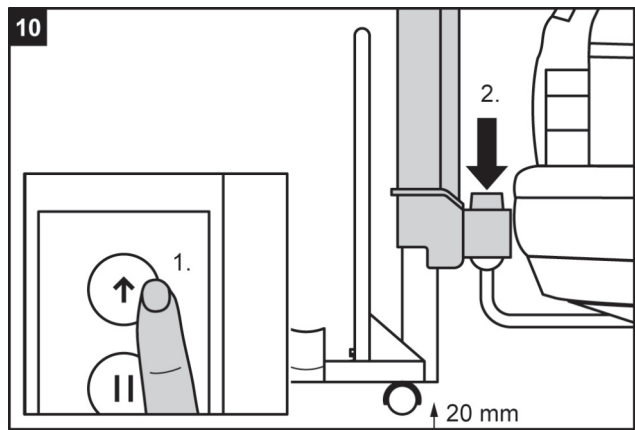
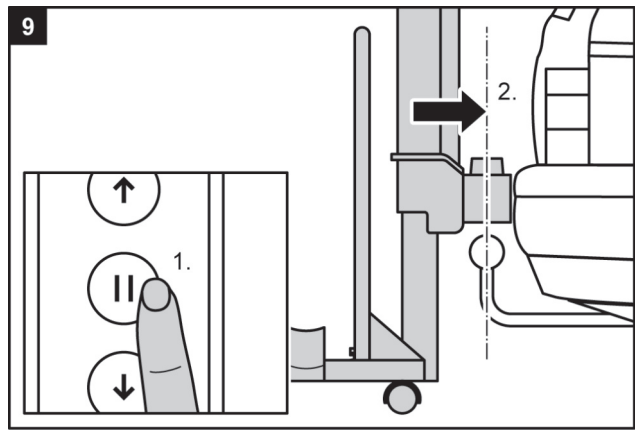
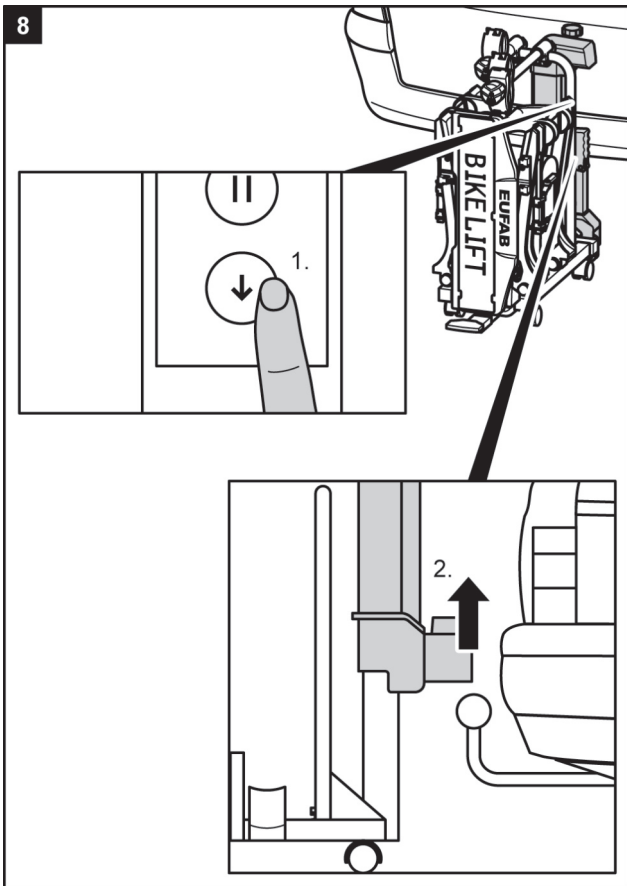
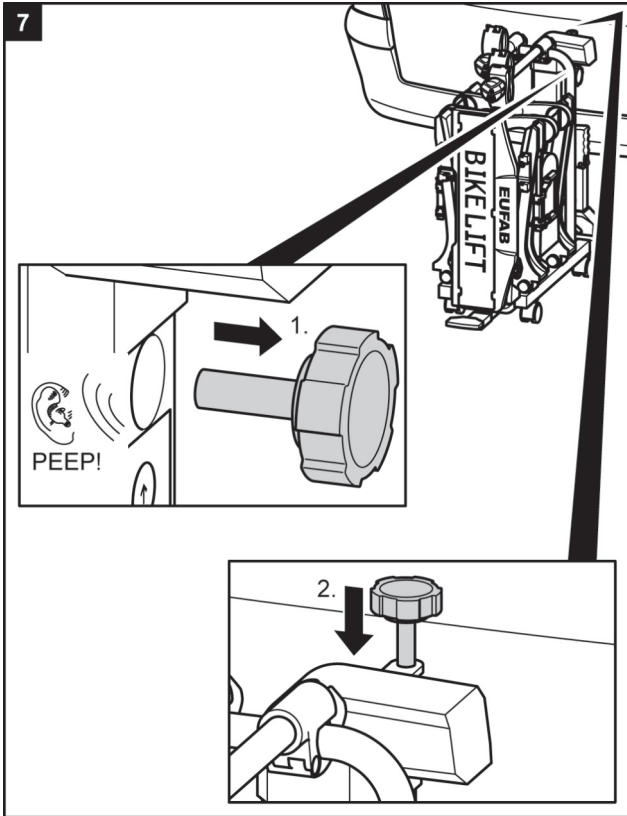

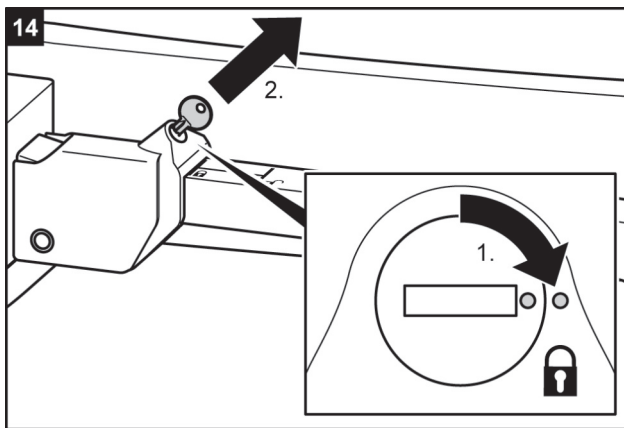
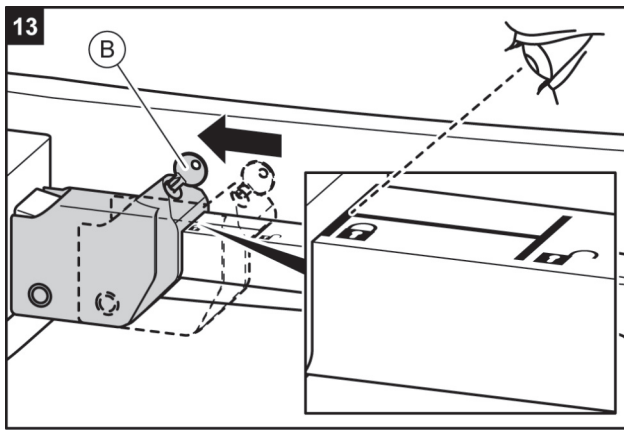

WARNUNG

Wird der Hebel nicht durch Abschließen gesichert, könnte sich der Fahrradträger während der Fahrt vom Fahrzeug lösen.

Personen- oder Sachschaden durch ungesicherten Fahrradträger.

- ⇒ Schließen Sie den Fahrradträger ab.
- ⇒ Prüfen Sie, ob Sie den Hebel abgeschlossen und den Schlüssel abgezogen haben.

Durch das Abschließen beugen Sie auch einem eventuellen Diebstahl des Fahrradträgers vor



WARNUNG

Eine lockere Verbindung zwischen Träger und Anhängerkupplung kann zum Lösen des Fahrradträgers führen.

Personen- oder Sachschaden durch Verlust des Fahrradträgers während der Fahrt.

- ⇒ Prüfen Sie den Fahrradträger auf sichere Befestigung.
- ⇒ Wiederholen Sie bei lockerer Verbindung die Arbeitsschritte 1 bis 14. Sollte sich keine Besserung einstellen, muss evtl. der Schnellverschluss nachgestellt werden, siehe Kapitel Wartung.

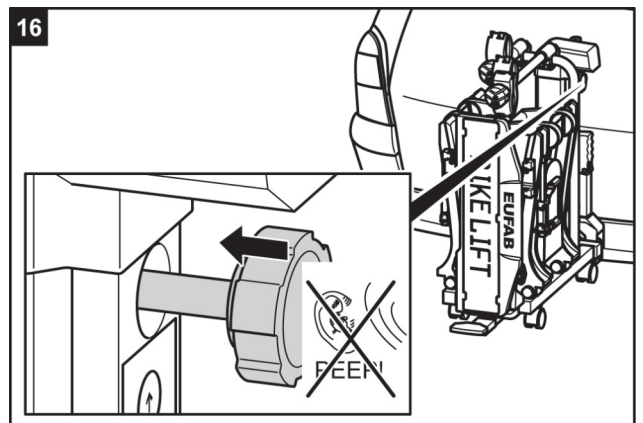
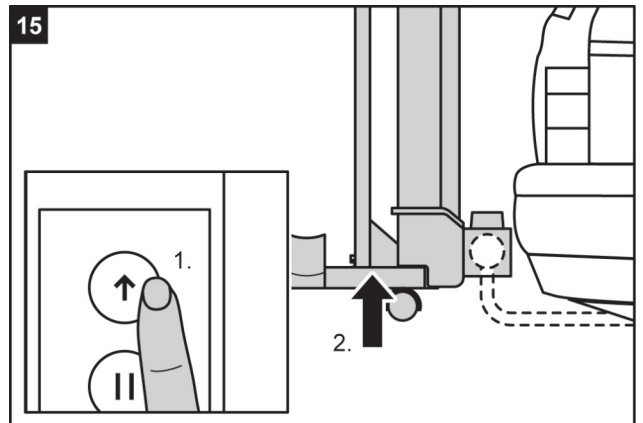

- ⇒ Ab dem folgenden Schritt ist die Montagefolge für manuelles und automatisches Heben identisch.

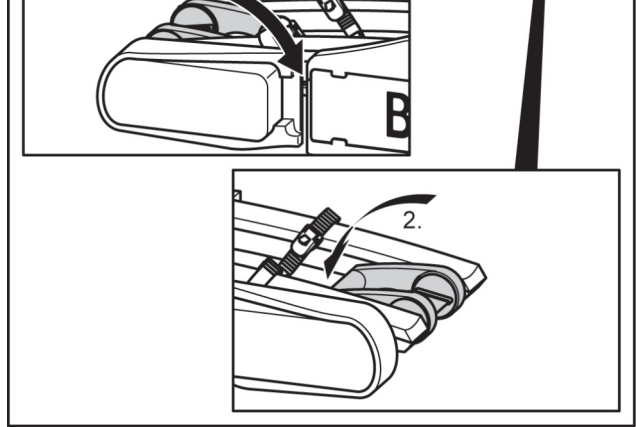
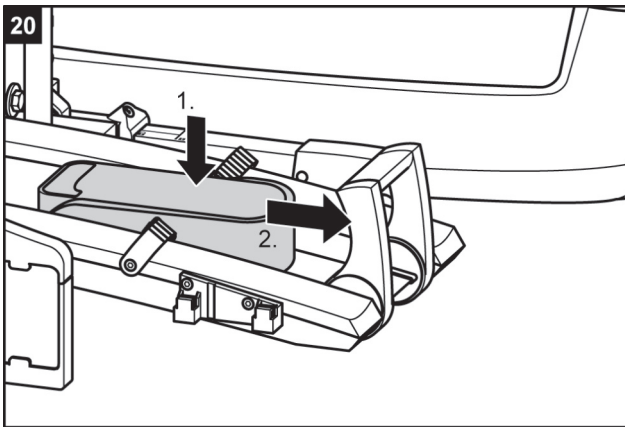
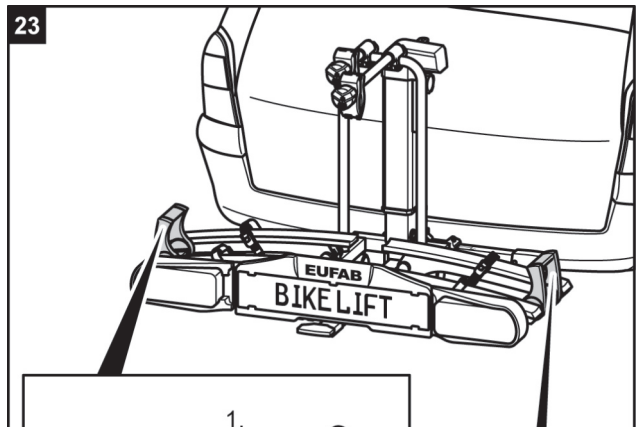
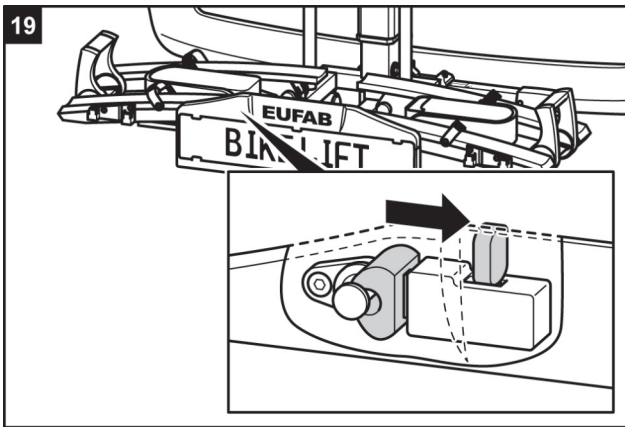
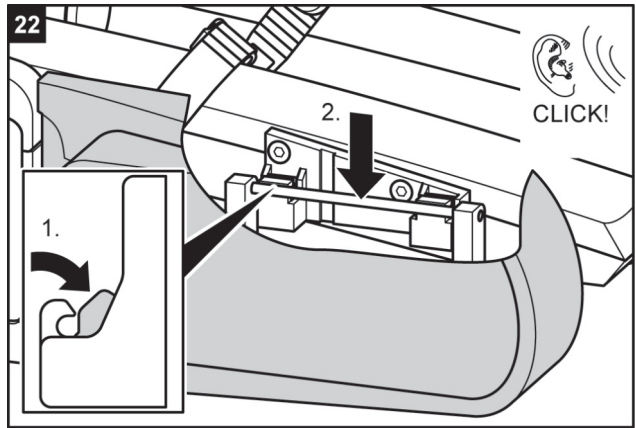
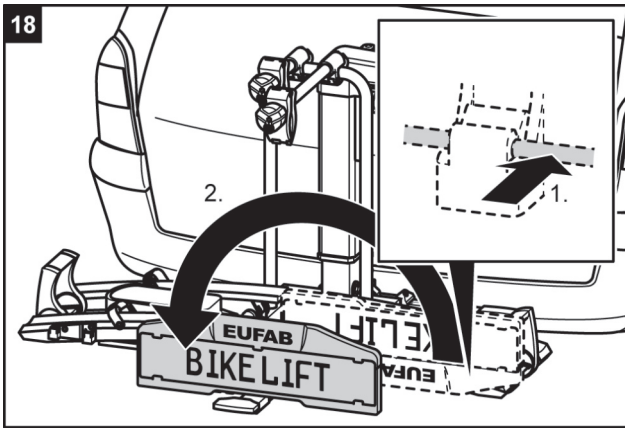
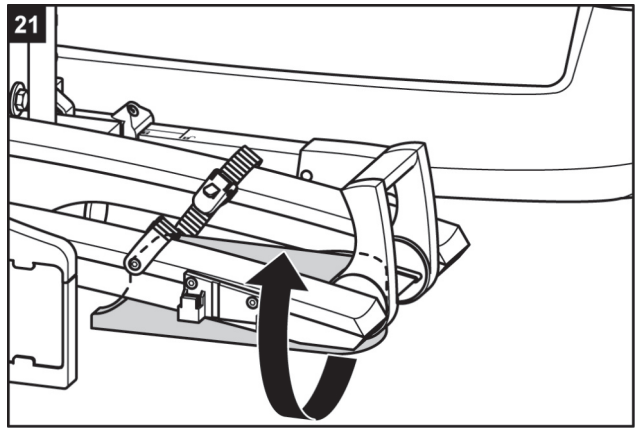
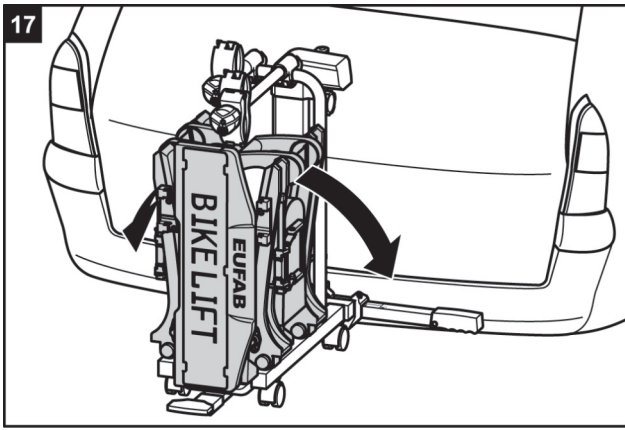

**WARNUNG**

Fahren ohne funktionsfähige Beleuchtungsanlage kann zu Unfällen führen.

Personenschaden durch nicht Wahrgenommen werden von anderen Verkehrsteilnehmern.

- ⇒ Überprüfen Sie vor jedem Fahrtantritt die korrekte Funktion der Beleuchtungsanlage.
- ⇒ Wechseln Sie ggf. defekte Glühlampen aus.
- ⇒ Prüfen Sie die Verbindung zwischen Stecker und Kupplung.

Fahrradträger absenken und anheben

Absenken des Fahrradträgers

**WARNUNG**

Ein nicht angehobener oder ungesicherter Fahrradträger kann sich an Hindernissen verfangen.

Personen- oder Sachschaden durch Verlust des Fahrradträgers während der Fahrt.

- ⇒ Heben Sie den Fahrradträger vor jeder Fahrt bis zur Endstellung an.
- ⇒ Sichern Sie unbedingt den Fahrradträger mit dem Sicherungsstift wie unter „Anheben des Fahrradträgers“ beschrieben.

**VORSICHT**

Körperteile oder Gegenstände, die sich beim Herunterfahren unter dem Träger befinden, können gequetscht werden.

Personen- oder Sachschaden durch das Absenken des Trägers.

- ⇒ Vergewissern Sie sich, dass sich nichts unter dem Träger befindet.
- ⇒ Achten Sie auf Ihren Körper, halten Sie einen Sicherheitsabstand ein.

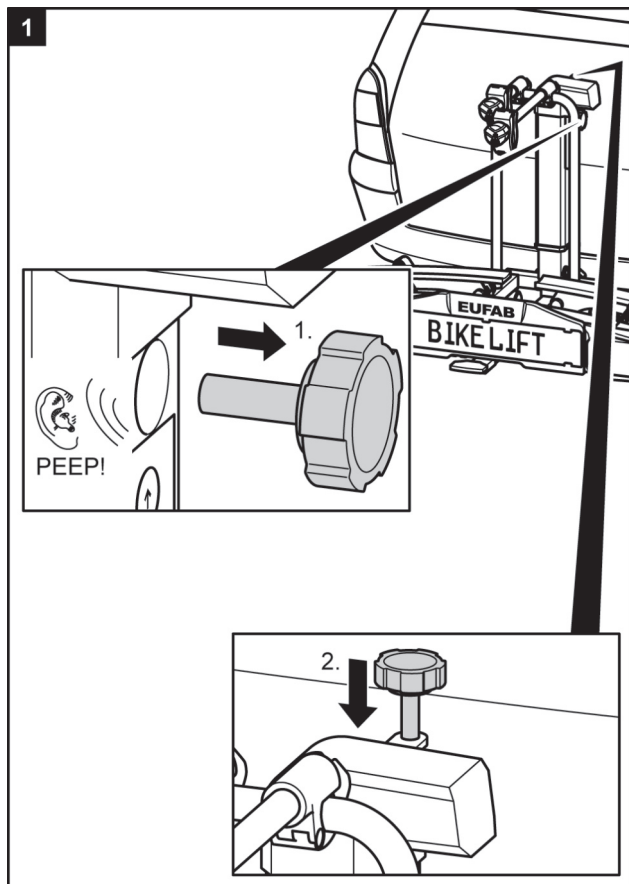

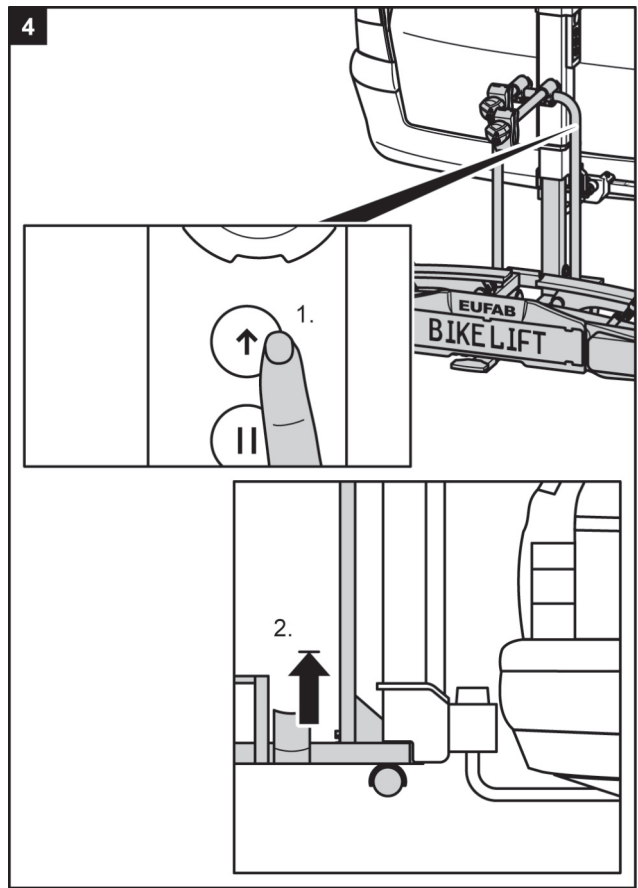
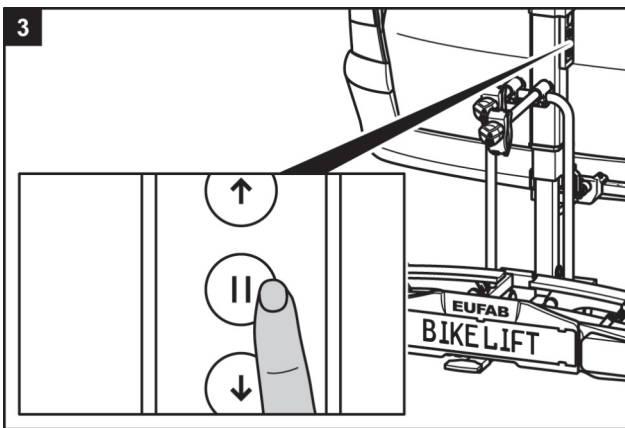
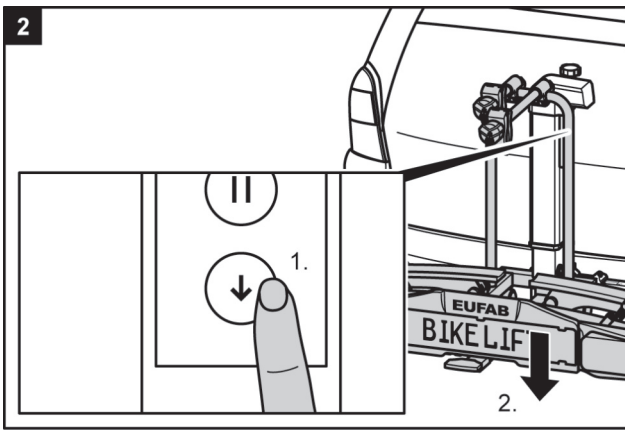

Anheben und Sichern des Fahrradträgers

- ⇒ Heben Sie den Fahrradträger bis zum Anschlag an.
- ⇒ Montieren Sie den Sicherungsstift.
Der Stift lässt sich nur montieren, wenn sich der Fahrradträger in der oberen Endstellung befindet.
- ⇒ Nach der Montage des Sicherungsstiftes erlischt der Warnton.



WARNUNG

Das Absenken des Trägers während der Fahrt kann zu schweren Unfällen führen
Personen- oder Sachschaden durch das Absenken des Trägers während der Fahrt.

- ⇒ Vergewissern Sie sich, dass der Sicherungsstift nach dem Anheben vollständig eingedreht ist.
- ⇒ Sollte der Stift bei Fahrtantritt nicht vollständig eingedreht sein, ertönt ein Warnton.
- ⇒ Lösen Sie gegebenenfalls nochmal den Sicherungsstift, heben Sie den Fahrradträger bis zum Anschlag an und drehen Sie dann den Sicherungsstift ganz ein.

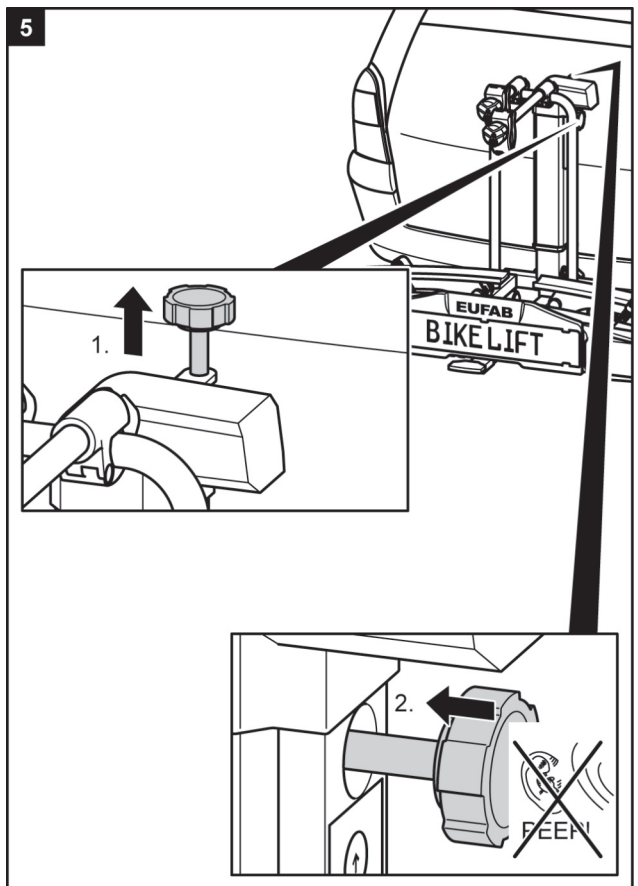

Fahrräder befestigen

⇒ Senken Sie zunächst wie im Kapitel „Absenken des Fahrradträgers“ beschrieben die Stellfläche für die Fahrräder ab.



HINWEIS

Sollte der Fahrradträger nach dem Absenken nicht auf dem Boden aufsetzen, können Sie den Fahrradträger zusätzlich kippen um die Fahrräder ohne anheben auf den Träger zu rollen. Gehen Sie dafür wie im Kapitel „Fahrradträger kippen“ beschrieben vor.



WARNUNG

Nicht fest verschraubte Teile an den Fahrrädern können sich während der Fahrt lösen.

Personen- oder Sachschaden durch herumfliegende Teile möglich.

- ⇒ Entfernen Sie alle nicht fest mit dem Fahrrad verbundenen Teile, wie z. B. Luftpumpen, Fahrradtaschen, Navigationsgeräte, Batterien oder Akkus.
- ⇒ Entfernen Sie auch alle Teile die zusätzlichen Luftwiderstand erzeugen, wie z. B. Gepäckkörbe und Kindersitze.



HINWEIS

Um das Fahrverhalten Ihres Fahrzeugs zu verbessern, montieren Sie am besten das schwerste Fahrrad zuerst. Außerdem sollten Sie, wenn Sie nur ein Fahrrad montieren, das Fahrrad in die Schiene setzen, die sich am nächsten zum Heck des Fahrzeugs befindet.

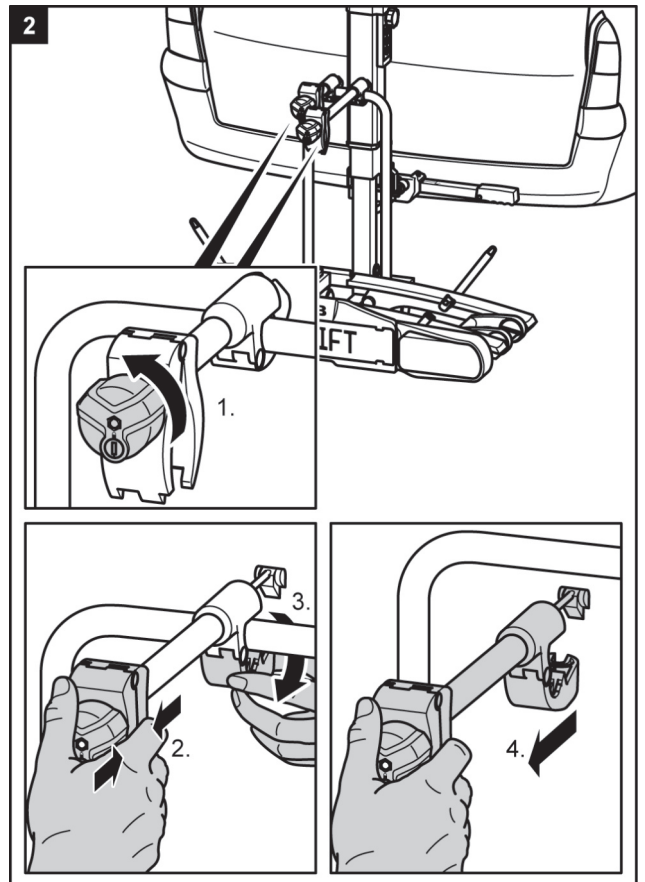
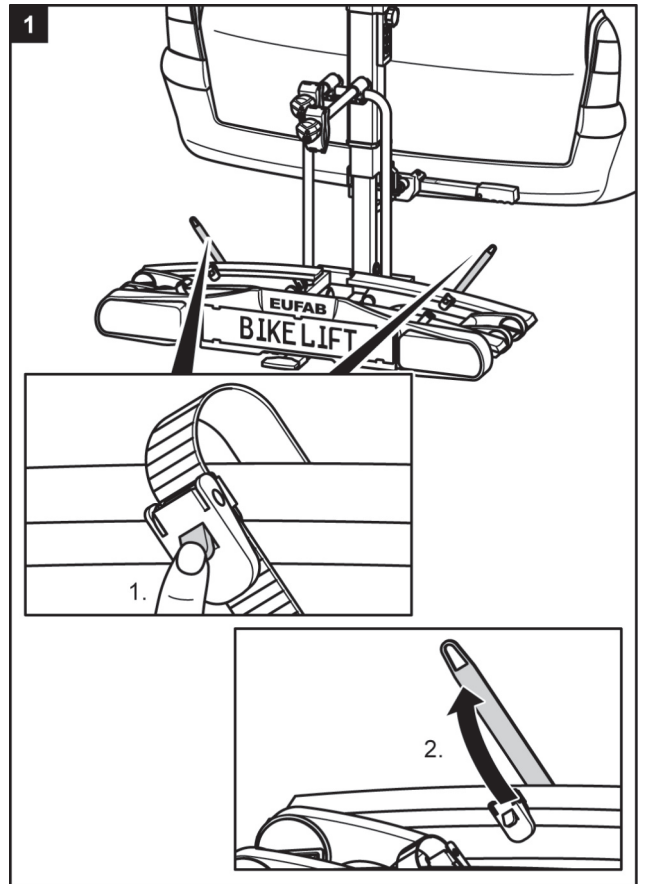

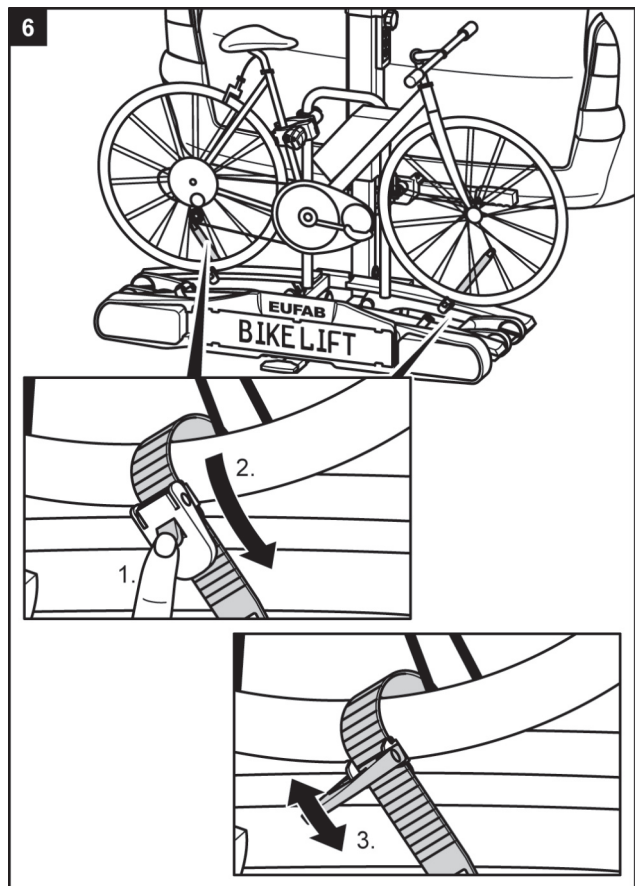
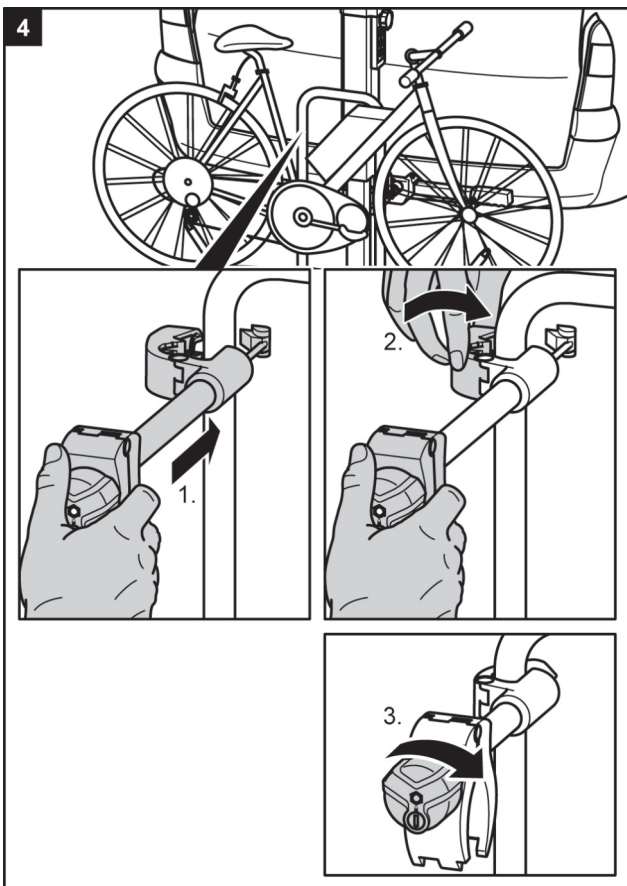
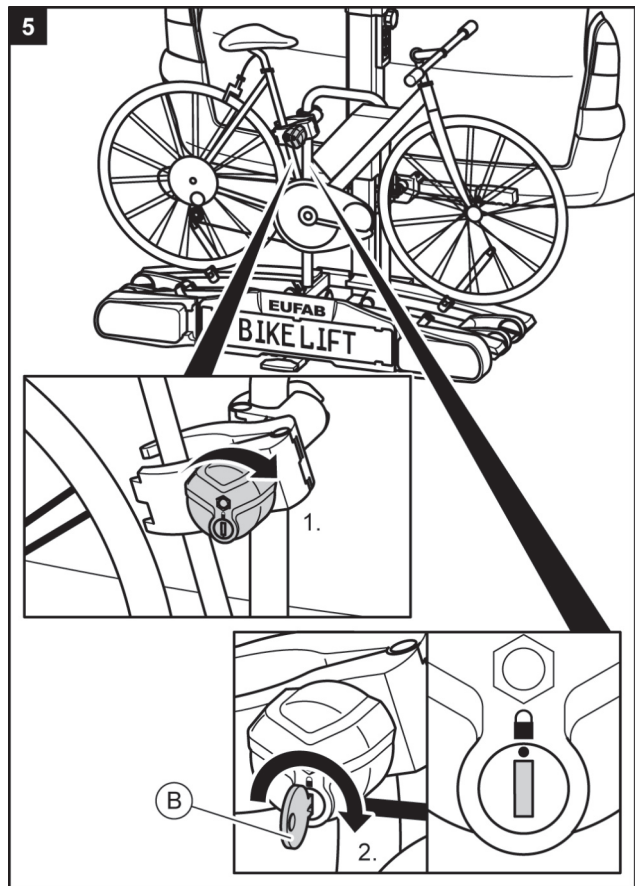
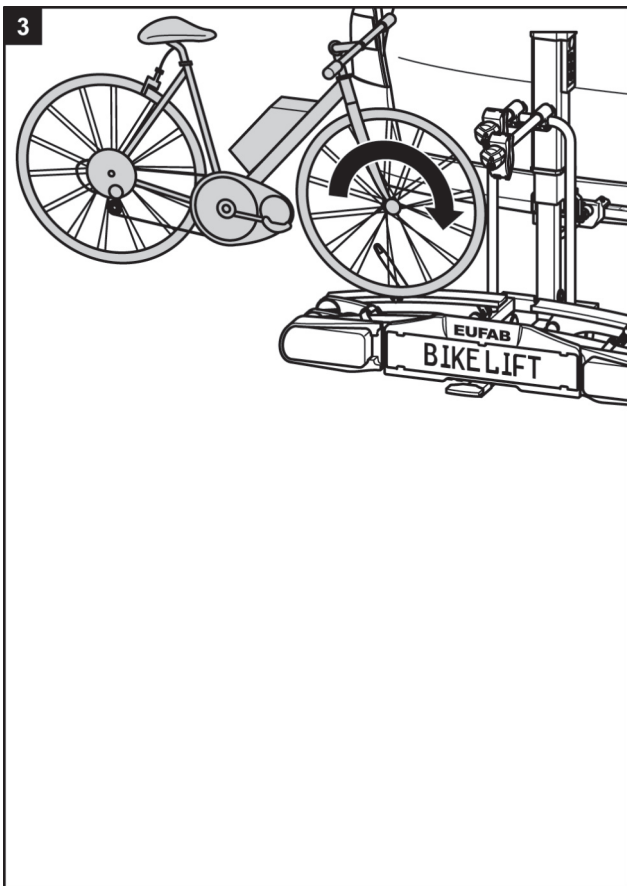

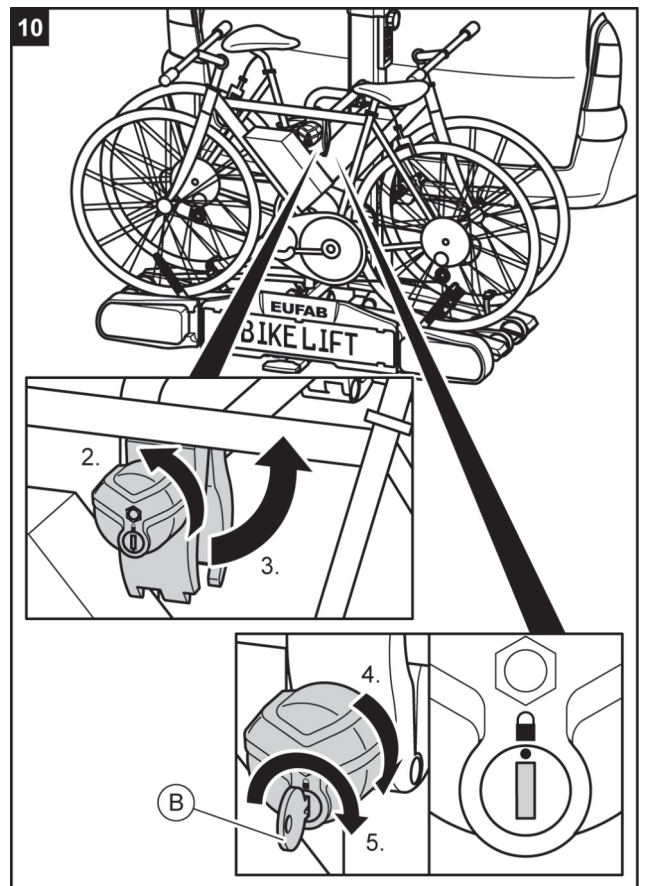
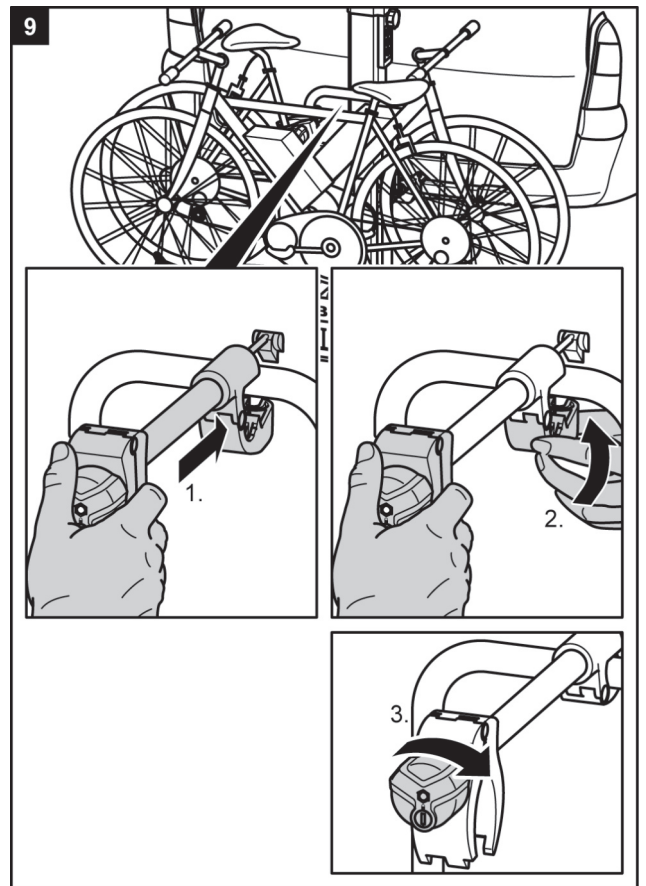
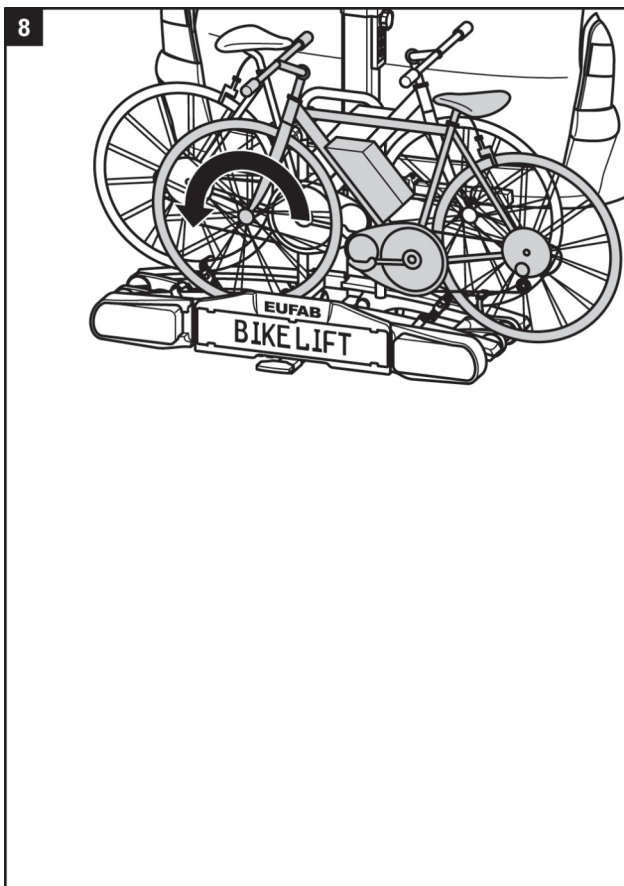
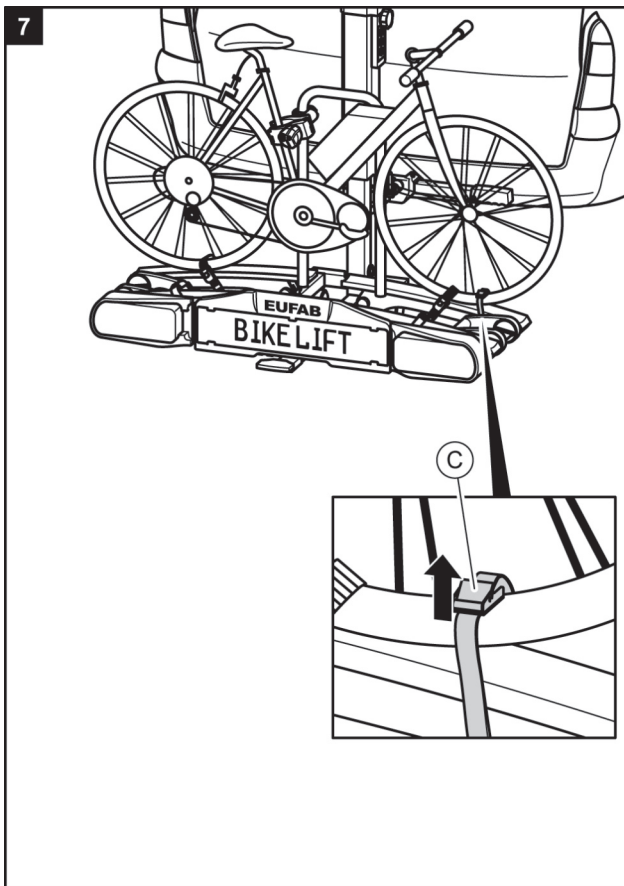

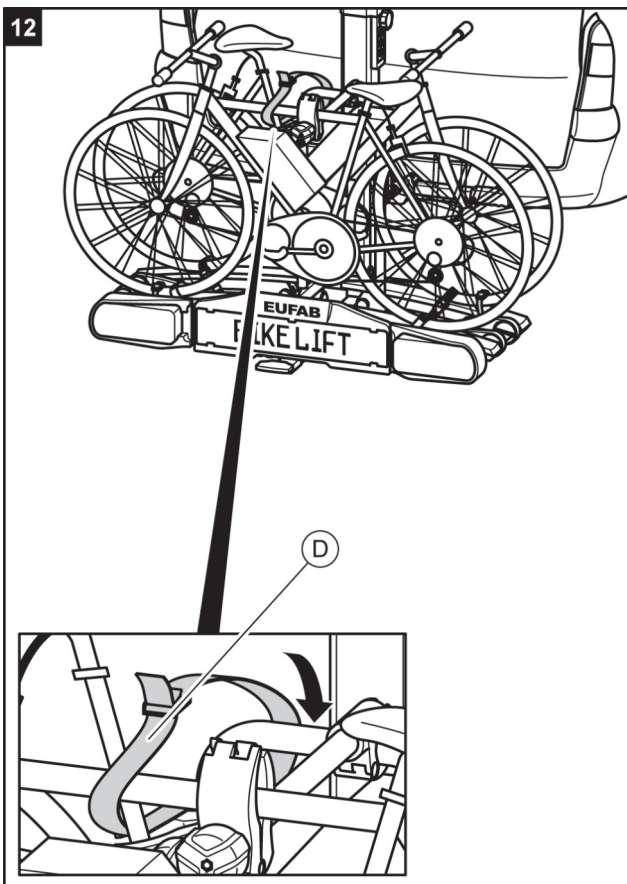
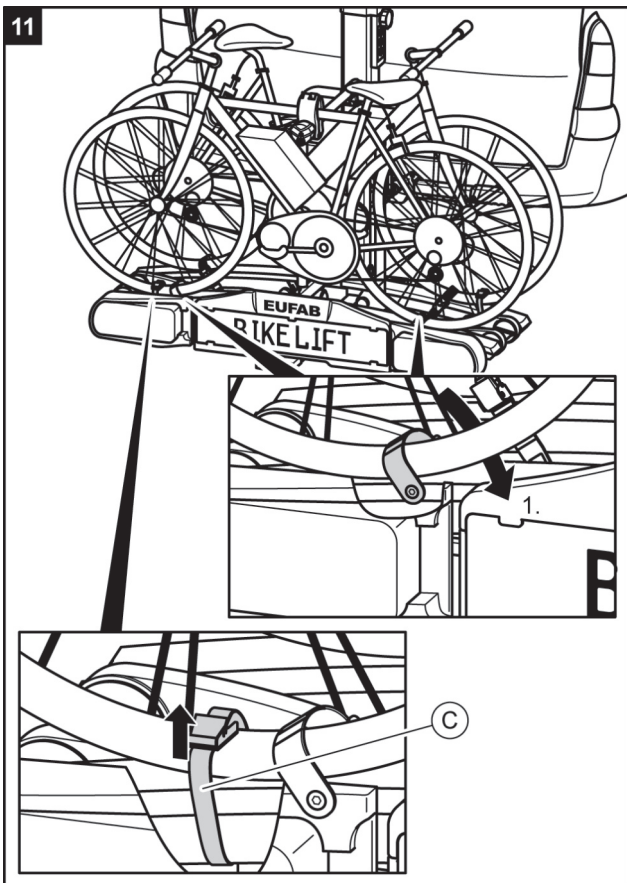
WARNUNG

Das Fahren ohne Sicherheitsgurte kann zu Unfällen führen.

Personen- oder Sachschaden durch Verlieren der Fahrräder.

- ⇒ Überprüfen Sie vor jedem Fahrtantritt den korrekten und festen Sitz des Gurtes um die Fahrräder und den U-Bügel des Trägers, siehe Schritt 12 in diesem Kapitel.
- ⇒ Überprüfen Sie vor jedem Fahrtantritt den korrekten und festen Sitz der beiden Gurte um das Vorderrad und den Gurt um das Hinterrad des Fahrrades.
- ⇒ Spannen Sie die Gurte ggf. nach.
- ⇒ Überprüfen Sie vor jedem Fahrtantritt, ob die verwendeten Gurte unbeschädigt und unverschlissen sind.
- ⇒ Beschädigte oder verschlissene Gurte müssen vor Fahrtantritt gegen unbeschädigte Gurte ausgetauscht werden. Es dürfen nur Gurte verwendet werden, die von der EAL GmbH dafür zugelassen sind.

WARNUNG

Eine lockere Verbindung zwischen Träger und Fahrrad kann zum Lösen der Verbindung und Verlust des Fahrrads führen.

Personen- oder Sachschaden durch Verlust eines Fahrrads während der Fahrt.

- ⇒ Prüfen Sie die Fahrräder auf sichere und vollständige Befestigung.
- ⇒ Wiederholen Sie bei lockerer Verbindung die Arbeitsschritte 1 bis 12 dieses Kapitels.

- ⇒ Heben Sie nun wie im Kapitel „Anheben des Fahrradträgers“ beschrieben den Fahrradträger an.



WARNUNG

Ein nicht angehobener oder ungesicherter Fahrradträger kann sich an Hindernissen verfangen.

Personen- oder Sachschaden durch Verlust des Fahrradträgers während der Fahrt.

- ⇒ Heben Sie den Fahrradträger vor jeder Fahrt bis zur Endstellung an.
- ⇒ Sichern Sie unbedingt den Fahrradträger mit dem Sicherungsstift wie unter „Anheben des Fahrradträgers“ beschrieben

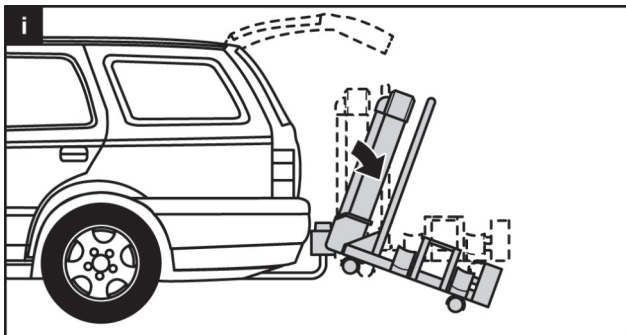
Fahrradträger kippen, Zugang zum Kofferraum



VORSICHT

Die Heckklappe könnte gegen den Fahrradträger schlagen und beschädigt werden.

Sachschaden durch öffnende Heckklappe.

- ⇒ Elektrische Heckklappen abschalten und manuell betätigen.
- ⇒ Klappen Sie den Fahrradträger vor dem Öffnen der Heckklappe ab.



VORSICHT

Personen- oder Sachschaden durch plötzliches Herunterklappen.

Körperteile oder Gegenstände, die sich beim Herunterklappen unter oder vor dem Träger befinden, können gequetscht werden.

- ⇒ Vergewissern Sie sich, dass sich nichts unter dem Träger befindet.
- ⇒ Achten Sie auf Ihren Körper, besonders Ihren Kopf, halten Sie einen Sicherheitsabstand ein.
- ⇒ Lösen Sie die Verriegelung (1.) Halten Sie den Träger beim Herunterklappen am U-Bügel fest (2.). Lösen Sie mit dem Fuß die Verriegelung (3.) und kippen Sie dann den Träger mit der Hand nach unten.

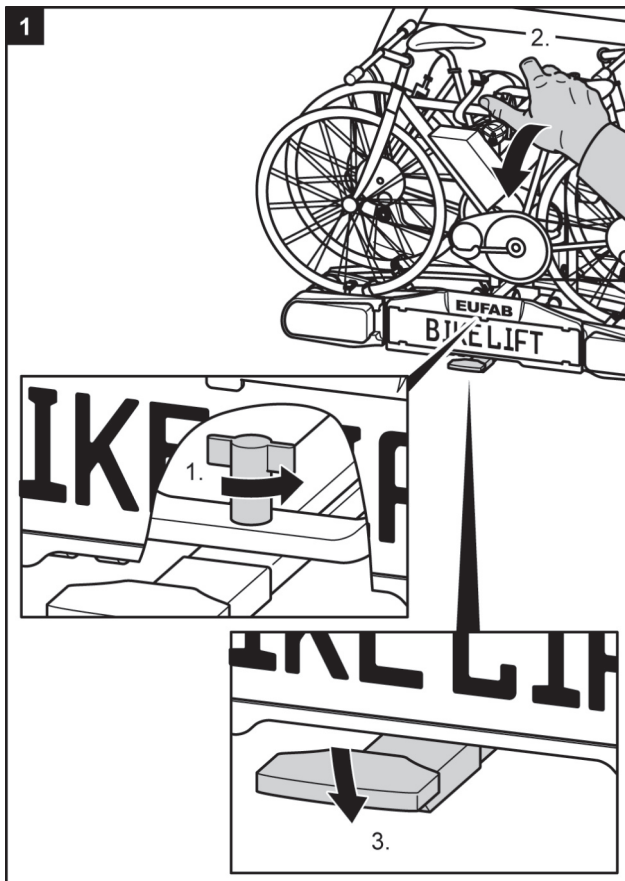

VORSICHT

Personen- oder Sachschaden durch Heraufklappen möglich.

Körperteile oder Gegenstände, die sich zwischen Träger und Fahrzeug befinden, können gequetscht werden.

- ⇒ Vergewissern Sie sich, dass sich nichts zwischen Träger und Fahrzeug befindet.
- ⇒ Entfernen Sie alles im Zwischenraum von Träger und Fahrzeug.

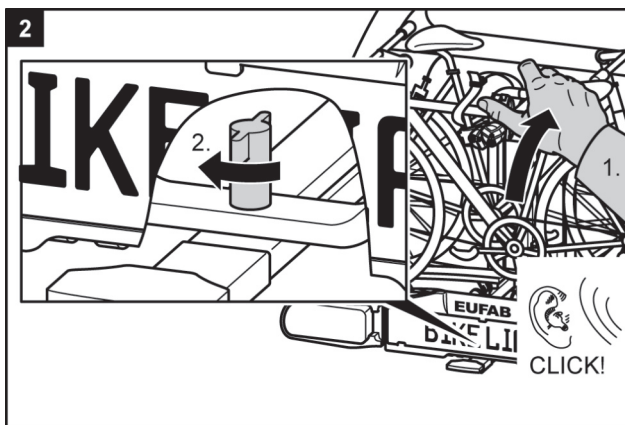



WARNUNG

Ein nicht hochgeklappter Fahrradträger kann zum Abreißen des Trägers oder der Kupplung führen.

Personen- oder Sachschaden durch Verlust des Fahrradträgers während der Fahrt möglich.

- ⇒ Klappen Sie den Träger vor der Fahrt hoch.
- ⇒ Prüfen Sie, ob der Fahrradträger richtig eingerastet ist. Rasten Sie den Träger ggf. wie zuvor beschrieben ein.

Demontage des Fahrradträgers

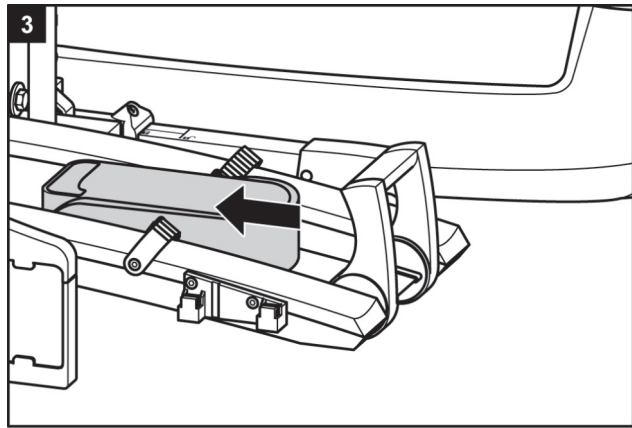
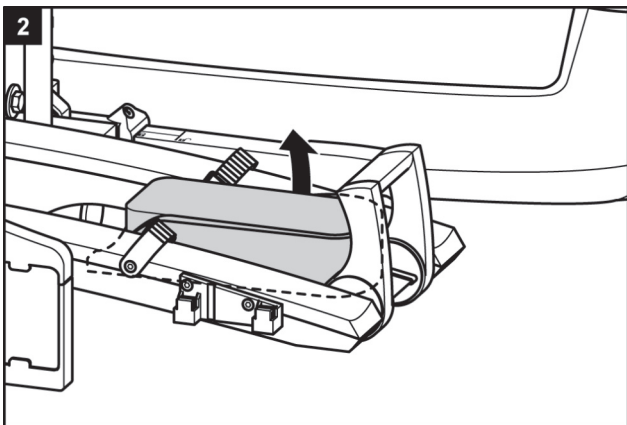
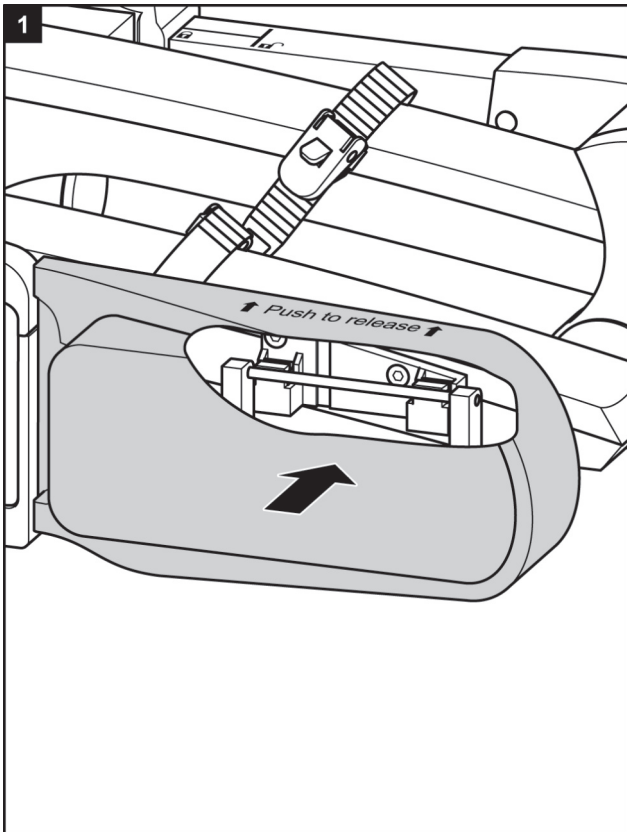

- ⇒ Lösen Sie zuerst den Verriegelungsbolzen hinter dem Kennzeichenhalter.

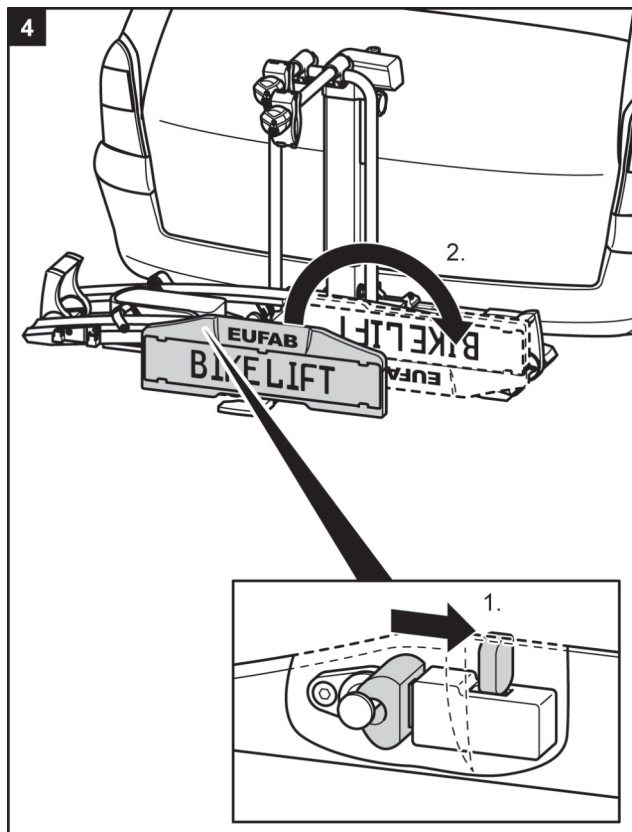

- ⇒ Beim Entfernen des Fahrradträgers gehen Sie anschließend in umgekehrter Reihenfolge der Montage vor.

Tragen des Fahrradträgers

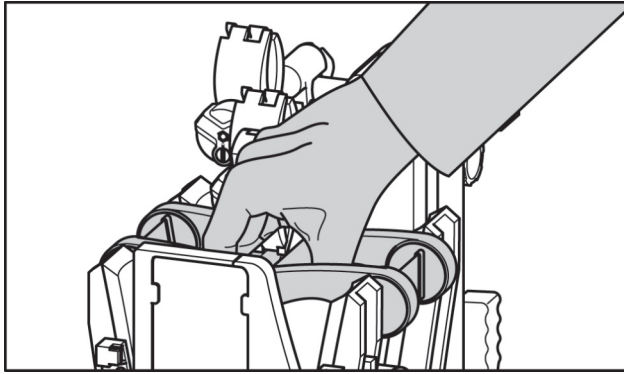

Rollen des Fahrradträgers

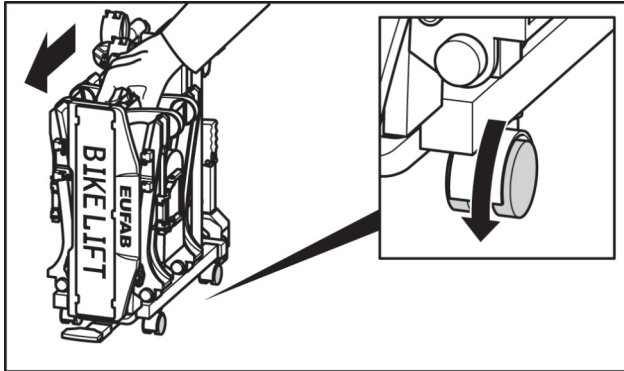

Verstauen des Fahrradträgers in der Schutzhülle

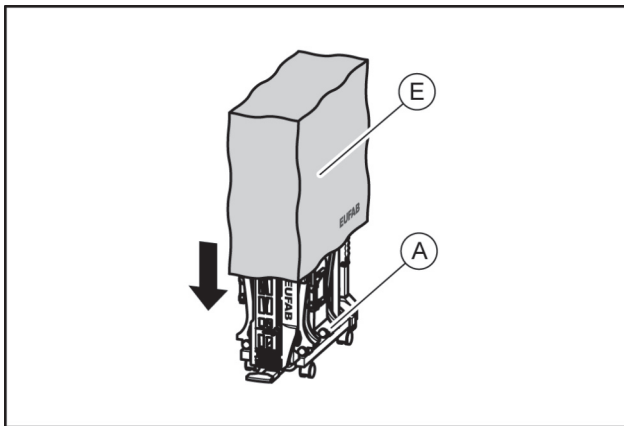

Reinigung und Pflege

Der Fahrradträger kann mit einem milden Reinigungsmittel, mit warmem Wasser und/oder einem weichen Tuch gereinigt werden.

Entfernen Sie vorher groben Schmutz und Staub. Benutzen Sie keine Lösungsmittel oder ähnliche Reiniger, da diese den Fahrradträger beschädigen können.

Lassen Sie den Fahrradträger von alleine trocknen. Benutzen Sie keinen Föhn oder andere Heizgeräte für eine Beschleunigung des Trocknungsvorgangs. Reinigen Sie den Fahrradträger im Küstenbereich und beim Einsatz bei Winterbedingungen regelmäßig, um Salz abzuspolen und die Haltbarkeit des Fahrradträgers zu verlängern.

Lagern Sie den Fahrradträger in längeren Zeiten ohne Benutzung (z. B. über den Winter) trocken und geschützt, um die Lebensdauer zu verlängern.

Wartung

Prüfen Sie vor jeder Fahrt den Fahrradträger auf Verschleiß. Insbesondere defekte Metallteile und Spannriemen müssen ausgetauscht werden.

Für den Austausch der Teile wenden Sie sich an unseren Kundenservice.

Jegliche Veränderung an Originalteilen und Materialien oder an der Konstruktion des Fahrradträgers kann die Sicherheit und Leistungsfähigkeit beeinträchtigen.

Die Stahlteile des Fahrradträgers wurden werksseitig durch eine Pulverlackbeschichtung gegen Korrosion geschützt. Ist diese Lackschicht beschädigt, sorgen Sie schnellstmöglich für eine professionelle Beseitigung des Schadens.

Bei normalen Bedingungen ist der Fahrradträger nur zu reinigen und ansonsten wartungsfrei.

Nachstellen des Schnellverschlusses

Führen Sie diese Wartung nur durch, wenn sich der Fahrradträger, wie im Kapitel Montage beschrieben, nicht fest auf der Anhängerkupplung montieren lässt.

- ⇒ Nehmen Sie den Fahrradträger von der Anhängerkupplung ab, wie unter Demontage beschrieben.
- ⇒ Ziehen Sie die Staubschutzkappe ab.
- ⇒ Lösen Sie, wie auf der Abbildung zu sehen, die Kontermutter etwas.
- ⇒ Drehen Sie die Stellschraube eine viertel Umdrehung hinein.
- ⇒ Ziehen Sie die Kontermutter fest.
- ⇒ Prüfen Sie, ob der Träger nun fest auf der Anhängerkupplung sitzt, wie unter Montage beschrieben. Wenn nicht, wiederholen Sie die oben beschriebenen Schritte.

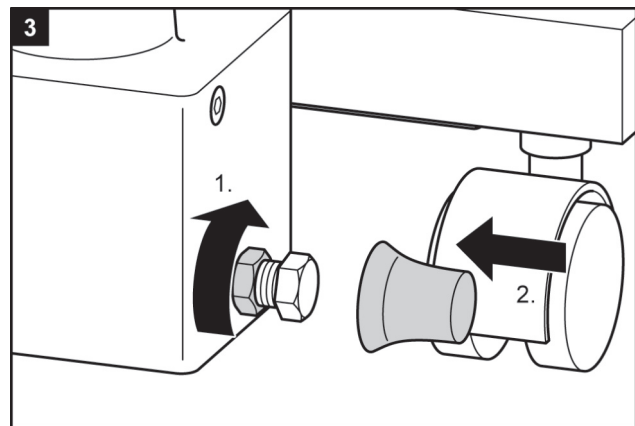
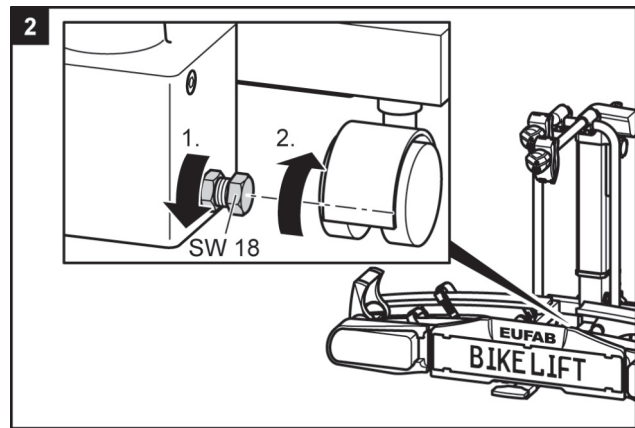
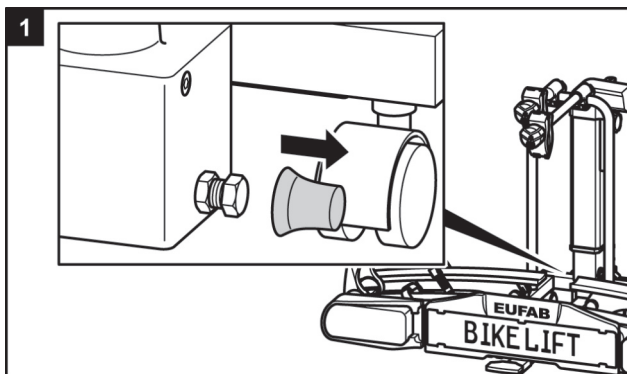

Entsorgung

Für die Entsorgung sind die örtlichen, behördlichen Vorschriften zu beachten.

Entsorgen Sie auch die Verpackung sortenrein in den dafür vorgesehenen Sammelbehältern.

Nähere Informationen erhalten Sie bei Ihrer kommunalen Entsorgungsstelle.

Kontakt

EAL GmbH
 Otto-Hausmann-Ring 107
 42115 Wuppertal
 GERMANY

Telefon: +49 (0) 202 - 429283-0
 Telefax: +49 (0) 202 - 429283-20
 E-Mail: info@eal-vertrieb.com

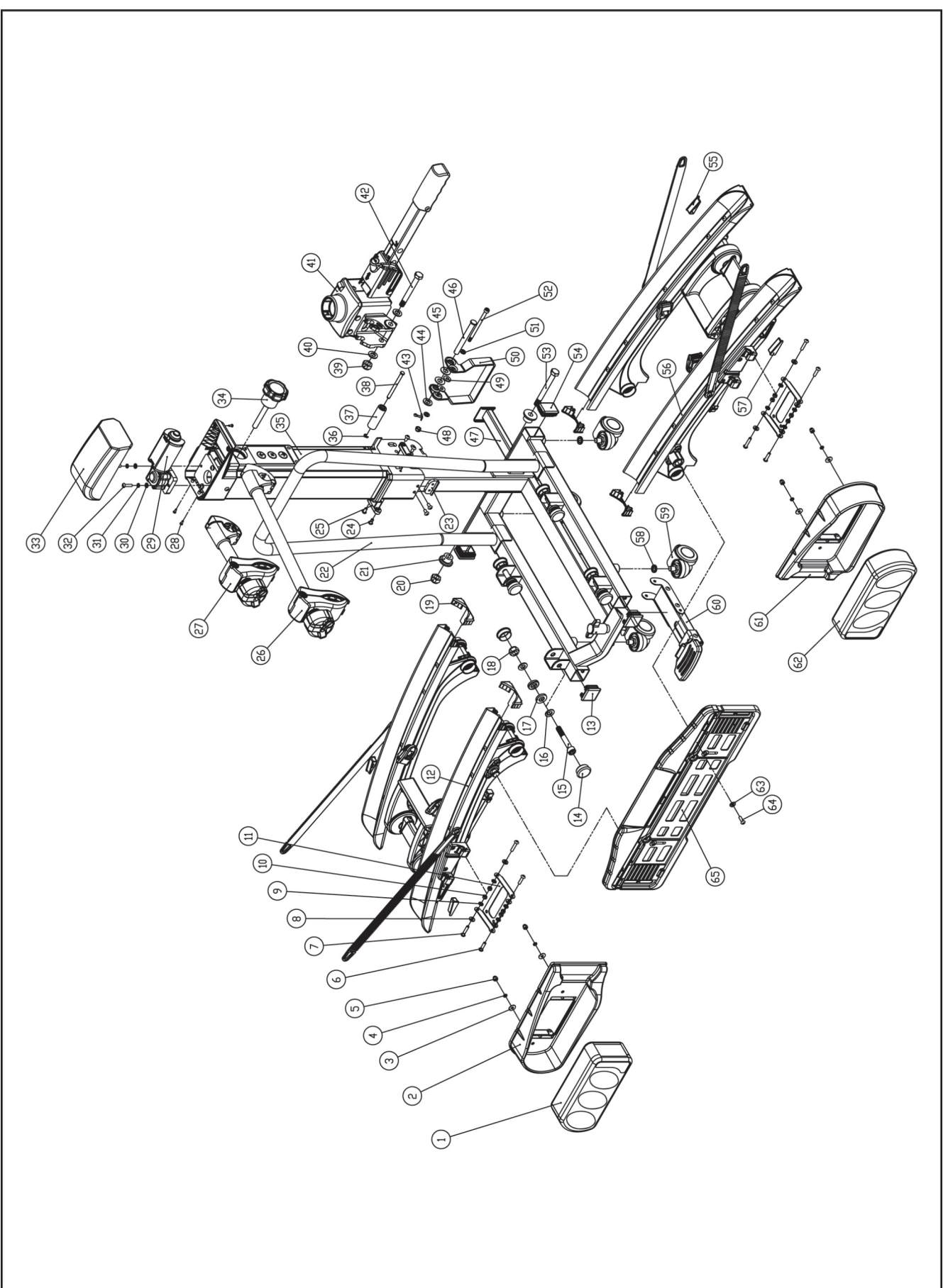

Pos.	Menge	Bezeichnung
1	1	Lamp complete right
2	1	Lamp guard right
3	4	Washer M5
4	4	Spring washer M5
5	4	Capped nut M5
6	4	Screw M5X20
7	4	Screw M5X25
8	8	Nylon washer M5
9	8	Washer M5
10	8	Self-locking nut M5
11	2	Lamp countersink
12	1	Left wheel rail with tension belt and carrier handle
13	2	Stopper for Nr.22,35X35mm
14	8	Round stopper for Nr.12
15	4	Bolt M10X65
16	8	Washer M10
17	8	Nylon washer M10
18	4	Self-locking nut M10
19	4	End cap aluminium rail interior
20	1	Self-locking nut M10
21	2	Stopper bearing pad
22	1	Carrier table bracket and U-bracket
23	1	Small plastic stopper 1
24	6	Screw M5X10
25	2	Small plastic stopper 2
26	1	Lock bracket long
27	1	Lock bracket short
28	4	Screw ST 2.9X9.5
29	1	Motor
30	2	Washer M5
31	2	Spring washer M5
32	2	Screw M5X20
33	1	Plastic cover for lift bracket

Pos.	Menge	Bezeichnung
34	1	Safety pin
35	1	Lift bracket
36	1	Jump ring
37	1	Nylon roller
38	1	Pin ø6
39	1	Self-locking nut M10
40	2	Washer M10-2.0
41	1	quick release
42	1	Bolt M10X87
43	1	Split pin ø3.2X25
44	2	Washer M10-2.0
45	2	Big washer M10-1.2
46	1	Pin ø10
47	1	Push rod
48	1	Self-locking nut M6
49	2	Big washer M6-1.2
50	1	Tilting operator
51	2	Washer M6-1.6
52	1	Bolt M6X85
53	1	Bolt M10X95
54	2	Stopper for Nr.22,30X40mm
55	2	Triangle end cap 1
56	1	right wheel rail with tension belt and carrier handle
57	2	Triangle end cap 2
58	4	Spring washer M10
59	4	Universal castor
60	1	Kick plate for locking mechanism
61	1	Lamp guard left
62	1	Lamp complete left
63	1	Nylon washer M5
64	1	Screw M5X16
65	1	Registration plate bracket

Steckerbelegung

Der Fahrradträger ist mit einer Beleuchtungsanlage ausgestattet. Diese wird mit einem 13-poligen Stecker an der Steckdose der Anhängerkupplung angeschlossen. Sollte Ihr Fahrzeug statt über einen 13 poligen nur über einen 7 poligen Anschluss verfügen sind hier die entsprechenden Belegungen aufgeführt. Diese Information ist nur für die Umrüstung bei einem Fachbetrieb bestimmt. Eine Umrüstung durch nicht geschulte Personen ist nicht zulässig.

13 Pin

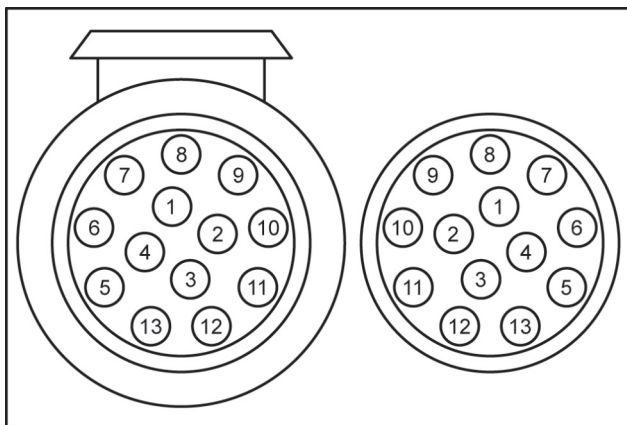

1	Blinker links	gelb
2	Nebelschlussleuchte	blau
3	Masse	weiß
4	Blinker rechts	grün
5	Schlussleuchte rechts	braun
6	Bremsleuchten	rot
7	Schlussleuchte links	schwarz
8	Rückfahrleuchte	grau
9	+12 V für Liftsystem	rot
10	Nicht belegt	–
11	Nicht belegt	–
12	Nicht belegt	–
13	-0 Masse für Liftsystem	schwarz

Bicycle carrier Bike Lift

Operating instructions

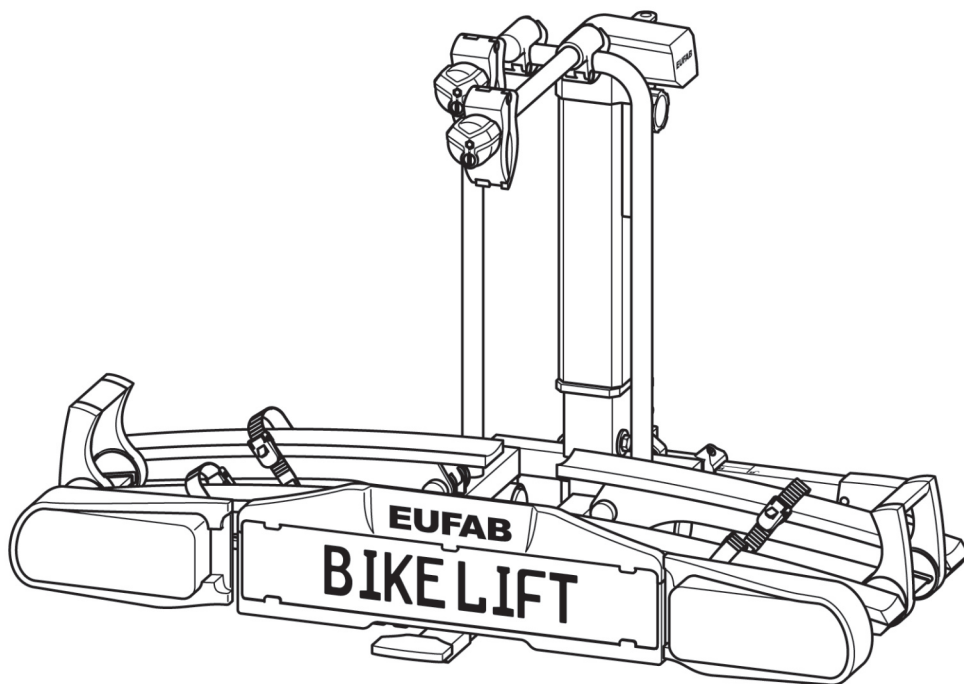

Bike Lift
Item no. 11535

Contents

Details about this Instruction Manual	27
Foreword.....	27
Obligations Concerning the Handling of this Instruction Manual.....	27
Intended Use	27
Explanation of the Safety Instructions	27
Delivery Contents	28
Technical Specifications	28
Coupling Requirements	28
Safety Instructions	29
Before Initial Use	30
Fitting the Number Plate on the Bicycle Carrier.....	31
Fitting and Use	31
Fitting the Bicycle Carrier on the Tow Hitch.....	31
Lifting the Bicycle Carrier onto the Tow Hitch Manually.....	32
Lifting the Bicycle Carrier onto the Tow Hitch with the Integrated Motor.....	33
Lowering and Raising the Bicycle Carrier	36
Lowering the Bicycle Carrier	36
Raising and Securing the Bicycle Carrier	37
Attaching Bicycles	38
Tilting the Bicycle Carrier, Access to the Boot	42
Removing the Bicycle Carrier	43
Carrying and Storage	44
Cleaning and Care	44
Maintenance	45
Disposal	45
Contact	45
Annex	46
Overview of Spare Parts (Exploded Drawing).....	46
Overview of Spare Parts (Table).....	47
Pin Assignment, 13-Pin.....	48

Details about this Instruction Manual

Foreword

This instruction manual helps you with the

- Proper and
- Safe

Use of the Bike Lift bicycle carrier.

Obligations Concerning the Handling of this Instruction Manual

Any person who

- Fits,
- Cleans or
- Disposes of

This bicycle carrier must have noted and understood the complete content of this instruction manual.

Always keep this instruction manual to hand and in a safe place. If the bicycle carrier is passed on, pass on the instruction manual with it.

Proper Use

The Bike Lift bicycle carrier serves to transport a maximum of two bicycles. It may be fitted only on tow hitches that meet the requirements specified in the chapter on Coupling Requirements.

Moreover, under no circumstances is the maximum permitted load of the bicycle carrier to be exceeded.

Proper use also includes adherence to all information in these fitting instructions and particularly adherence to the safety instructions. Any other use is considered to be improper and may cause damage to property or injury to people.

EAL GmbH accepts no liability for damages caused by improper use.

Explanation of the Safety Instructions

The following categories of safety instructions can be found in the instructions:



DANGER

Instructions with the signal word DANGER warn of a hazard with a high risk level.

If it is not avoided then it will result in death or serious injury.



WARNING

Instructions with the signal word WARNING warn of a potential hazard with a medium risk level.

If it is not avoided then it may result in death or serious injury.



CAUTION

Instructions with the signal word CAUTION warn of a potential hazard with a low risk level.

If it is not avoided then it may result in minor or moderate injury.



ATTENTION

Instructions with the word ATTENTION warn of a risk with potential damage to property.

If it is not avoided then the product or something nearby may be damaged.



NOTE

Other instructions:

Useful tip. Makes operation or fitting of the product easier or gives a better understanding.

The respective safety symbol used does not replace the text of the safety instruction.

You must therefore read the safety instruction and follow it exactly!

Delivery Contents

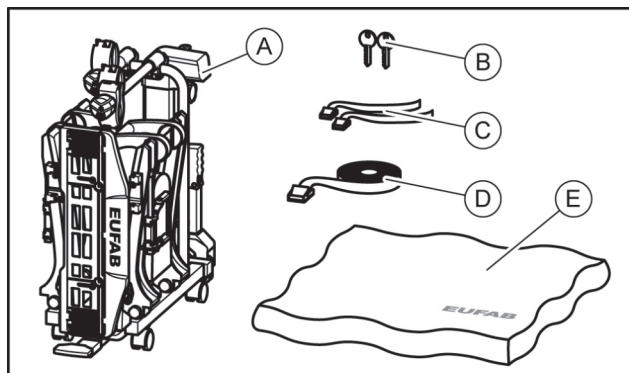

- A = Bicycle carrier
- B = 2 keys
- C = 2 safety belts for front wheels
- D = 1 safety belt for bicycle frames
- E = Protective cover

Technical Specifications

Material:	Aluminium Steel Plastic
Dead weight:	25 kg
Max. load:	60 kg
Power consumption, average:	2 A
Power consumption, maximum:	5,5 A
Dimensions (WxHxD), minimum:	30 × 74 × 74 cm
Dimensions (WxHxD), maximum:	135 × 74 × 74 cm
Packaging size (WxHxD):	81 × 77 × 33 cm

Do not exceed the max. load of the bicycle carrier and the permitted tongue load of the tow hitch!
The total permitted weight and permitted axle load of the vehicle must not be exceeded with the bicycle carrier and load.

Examples for Bike Lift

Max. tow hitch tongue load	Bicycle carrier dead weight	Max. load on the bicycle carrier
50 kg	25 kg	25 kg
60 kg	25 kg	35 kg
75 kg	25 kg	50 kg
90 kg	25 kg	max. 60 kg !

Coupling Requirements



DANGER

The tow hitch breaking can cause injury to people.

The coupling may break as a result of fitting the bicycle carrier on a coupling in a material that is too soft.

- ⇒ Fit the bicycle carrier only on a coupling made of St52 steel, GG52 grey cast iron or better quality.
- ⇒ Never fit the carrier on a coupling made of aluminium, other light metals or plastic.

Coupling Requirements

Fit the bicycle carrier only on tow hitches with the following properties:

Material:.....Min. St52 steel or GG52 grey cast iron

Dvalue..... ≥ 7,6 kN

Follow the instructions of the coupling manufacturer.

Safety Instructions

Follow the fitting instructions exactly. Not following the instructions can cause injury to people and damage to property.

If you are unsure when fitting, please ask your dealer or the manufacturer for further information. Neither the manufacturer nor the dealer is liable for damages due to improper use or incorrect fitting. Check the bicycle carrier and its load regularly! You have an obligation to do this and will be held responsible in the case of damage.



NOTE

A European operating licence is in place for this bicycle carrier. It is enclosed with this carrier and must be carried when the carrier is used.



NOTE

When driving with the bicycle carrier fitted, the legal requirements and regulations on transporting goods behind your vehicle apply.



WARNUNG

Driving with the bicycle carrier affects the handling properties of your vehicle.

Injury to people or damage to property due to altered vehicle behaviour.

- ⇒ Adjust your driving speed to the new vehicle behaviour.
- ⇒ Never drive faster than 130 km/h.
- ⇒ Avoid sudden and jerky steering movements.
- ⇒ Be aware that your vehicle is longer than usual.



WARNUNG

Parts that protrude beyond the edge of the vehicle or bicycle carrier may cause injury to people or damage to property during the journey.

Injury to people or damage to property due to protruding parts.

- ⇒ Fit only parts that do not protrude beyond the edge of the vehicle.



WARNING

Exceeding the max. load of the bicycle carrier and the permitted tongue load of the tow hitch or the total permitted weight can cause serious accidents.

Injury to people or damage to property due to overloading.

- ⇒ You must observe the specifications of the max. load, permitted tongue load and total permitted weight of your vehicle. Do not exceed these specifications in any circumstances!



WARNING

Travelling without safety belts can cause accidents.

Injury to people or damage to property due to loss of the bicycles.

- ⇒ Before beginning each journey, check that the belt around the bicycles and the carrier U-bracket is sitting correctly and securely, see chapter on "Attaching Bicycles".
- ⇒ Before beginning each journey, check that both belts around the front wheel and the belt around the back wheel of the bicycle are sitting correctly and securely.
- ⇒ Retighten the belts if necessary.
- ⇒ Before beginning each journey, check that the belts used are undamaged and unworn.
- ⇒ Replace damaged or worn belts with undamaged belts before beginning the journey. Use only belts that are approved by EAL GmbH for the purpose.



WARNING

Driving with the bicycle carrier folded up can cause accidents.

The moving parts of the bicycle carrier represent a safety hazard when not fully fitted.

Injury to people or damage to property due to incompletely fitted bicycle carrier.

- ⇒ Remove the bicycle carrier when you do not need it.
- ⇒ Never drive with the bicycle carrier folded up.



WARNING

Tarpaulins increase the air resistance. They can become detached and fly around, which can cause serious accidents.

Injury to people or damage to property due to tarpaulins.

⇒ Do not use tarpaulins.



WARNING

The carrier sits on the coupling properly only after fixing and a few kilometres travelled.

Injury to people or damage to property due to loss of the bicycle carrier.

⇒ Check that the carrier fixing is sitting properly after a few kilometres.

⇒ Refit if it is sitting loosely.



WARNING

Driving on rough terrain with the bicycle carrier fitted can cause the carrier to break off.

Injury to people or damage to property due to the bicycle carrier breaking off.

⇒ Do not use the bicycle carrier on rough terrain.



ATTENTION

The boot lid could hit the bicycle carrier and be damaged.

Damage to property due to boot lid opening.

⇒ Switch off electric boot lids and operate manually.

⇒ Fold down the bicycle carrier before opening the boot lid.



ATTENTION

The carrier or bicycles could be damaged if they are directly adjacent to the exhaust outlet.

Damage to property due to hot exhaust gases.

⇒ Use an exhaust embellisher if necessary

Before Initial Use

Fitting the Number Plate on the Bicycle Carrier

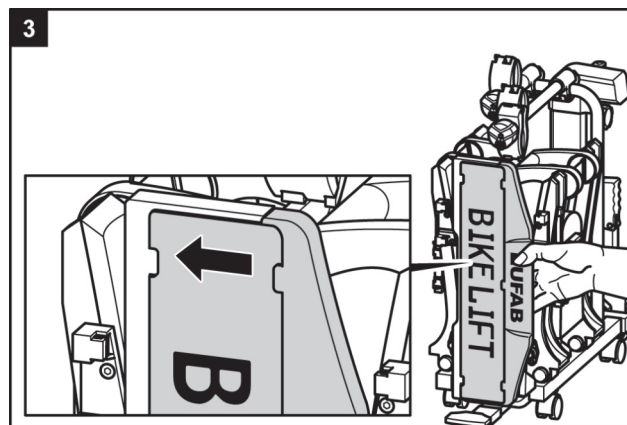
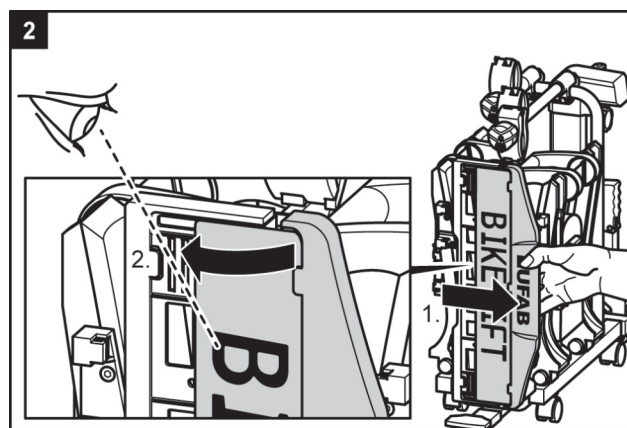
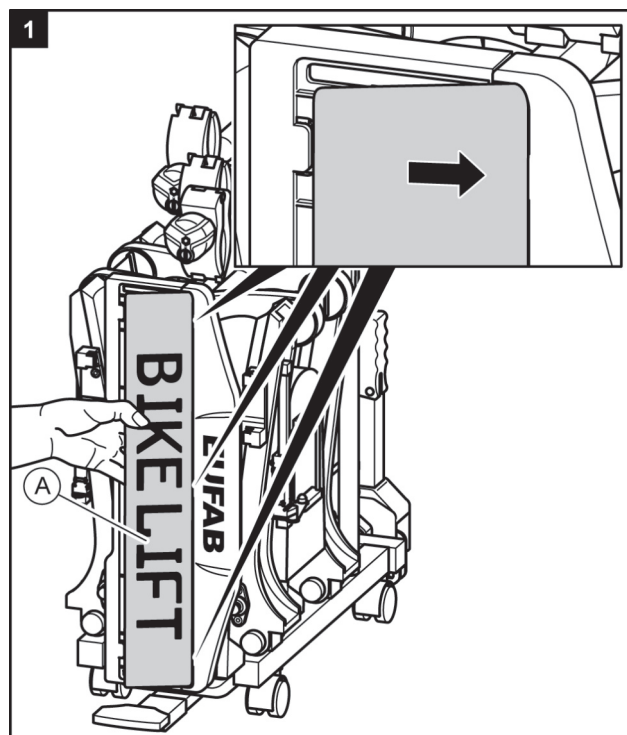

Fitting and Use

Fitting the Bicycle Carrier on the Tow Hitch

- ⇒ Park your vehicle on a flat surface.
- ⇒ Apply the handbrake.

Different fitting options

You can fit the bicycle carrier on the tow hitch in two different ways.

1. Manually lift the bicycle carrier onto the tow hitch.
 Advantage: Quick fitting.
 Disadvantage: Greater effort required than for fitting with the integrated motor.
 ⇒ Follow steps 1 – 6 and 17 – 23 in this chapter.
2. Lift the bicycle carrier onto the tow hitch using the integrated motor.
 Advantage: Only minimal effort required
 Disadvantage: Longer fitting time compared with manual fitting.
 ⇒ Follow steps 1 – 2 and 7 – 23 in this chapter.



WARNING

Damage to the carrier, e.g. due to bent parts, cracks or scratches, precludes safe functioning of the carrier.

Injury to people or damage to property due to damaged bicycle carrier.

- ⇒ Do not fit the bicycle carrier if there is any damage.
- ⇒ Proceed as described in the chapter on Maintenance.



WARNING

An unclean or damaged connection between the bicycle carrier and the tow hitch can cause the bicycle carrier to become detached.

Injury to people or damage to property due to loss of the bicycle carrier during the journey.

- ⇒ Replace a damaged tow hitch.
- ⇒ Clean dirt, dust and grease from the tow hitch.



NOTE

Couplings often have a coating layer on the tow ball.

To hold the bicycle carrier optimally, this coating layer must be removed carefully. Follow the instructions of the coupling manufacturer.

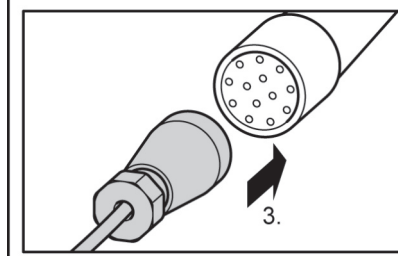
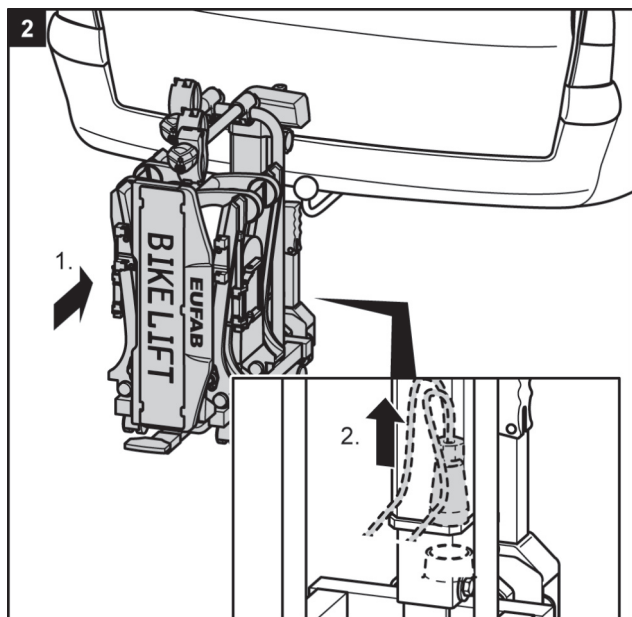
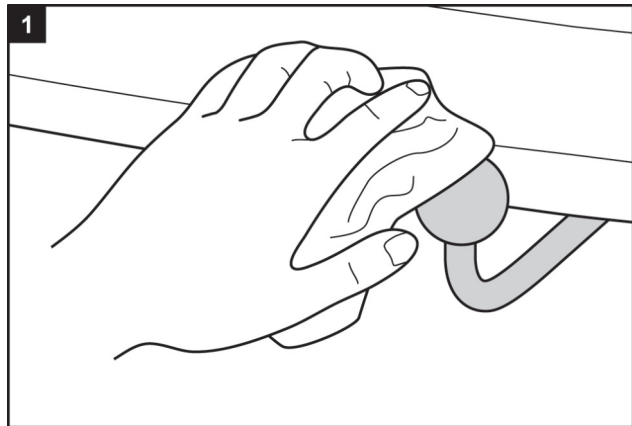

⇒ **3** If lifting manually, follow the next step.

⇒ **7** If lifting with the integrated motor, continue from step 7.

Lifting the Bicycle Carrier onto the Tow Hitch Manually.

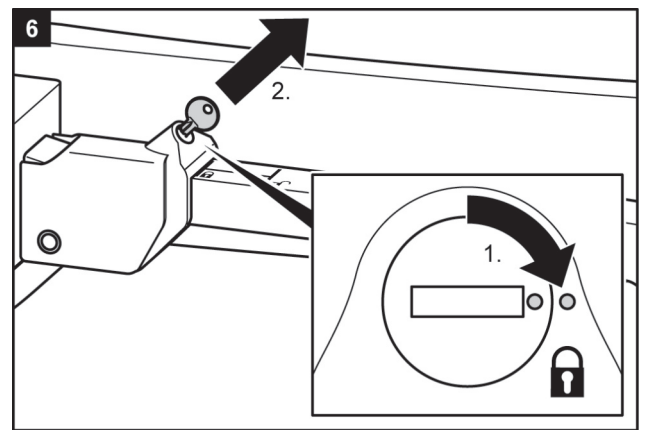
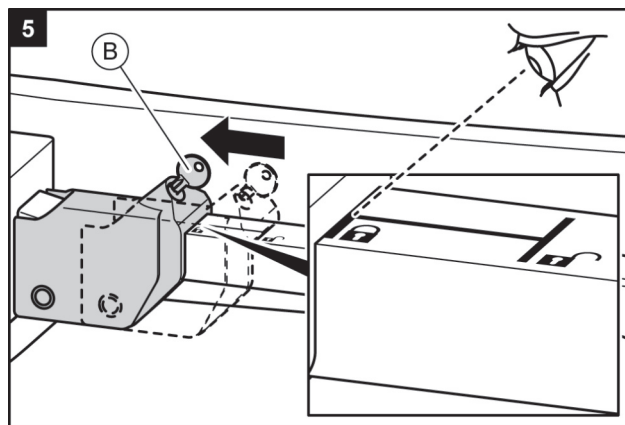
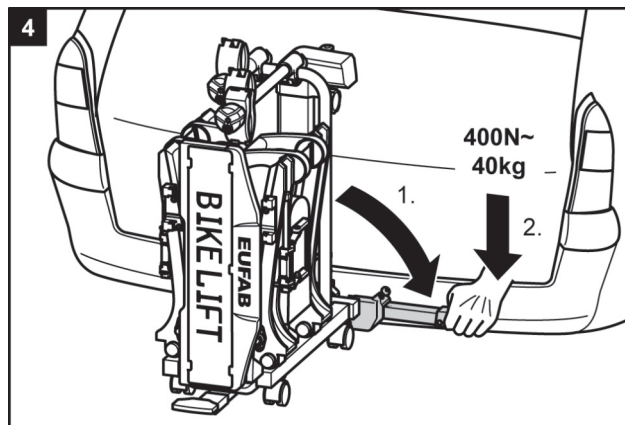
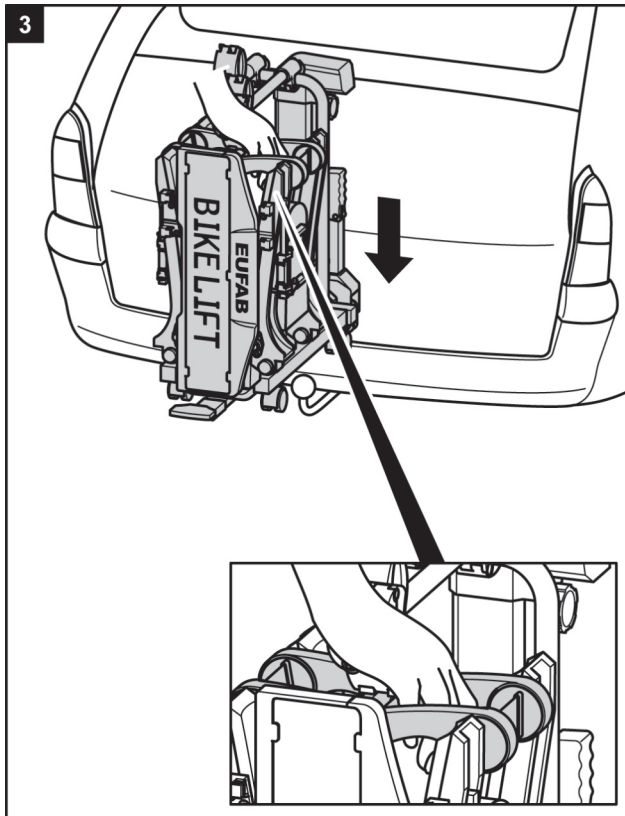

WARNING

If the lever is not locked to secure it, the bicycle carrier could become detached from the vehicle during the journey.

Injury to people or damage to property due to unsecured bicycle carrier.

- ⇒ Lock the bicycle carrier.
- ⇒ Check that you have locked the lever and removed the key.

Locking also prevents potential theft of the bicycle carrier.



WARNING

A loose connection between the carrier and the tow hitch can cause the bicycle carrier to become detached.

Injury to people or damage to property due to loss of the bicycle carrier during the journey.

- ⇒ Check that the bicycle carrier is fixed securely.
- ⇒ If the connection is loose, repeat steps 3 to 6. If no improvement occurs, the quick-release mechanism may require adjustment; see the chapter on Maintenance.

⇒ **17** From here, follow step 17 in this chapter.

Lifting the Bicycle Carrier onto the Tow Hitch with the Integrated Motor.

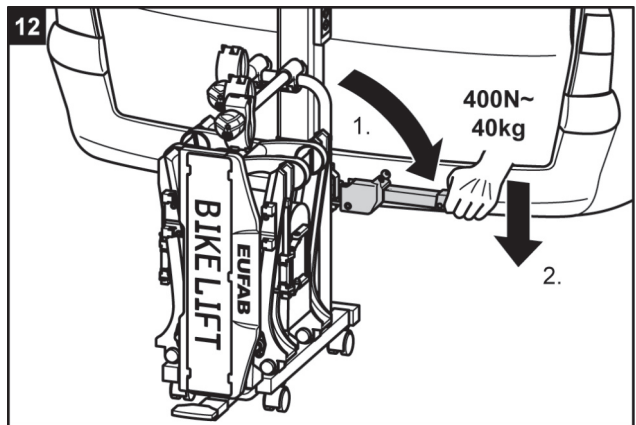
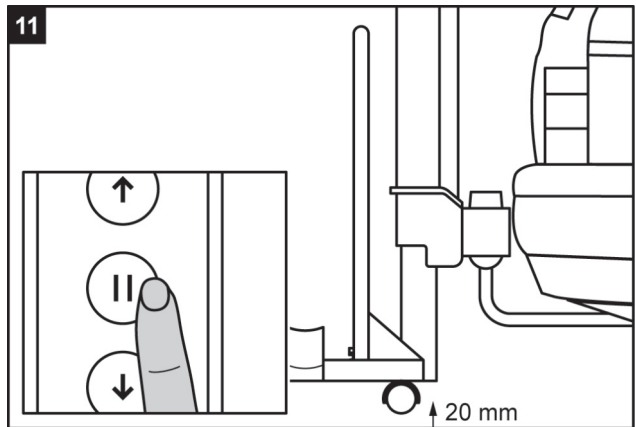
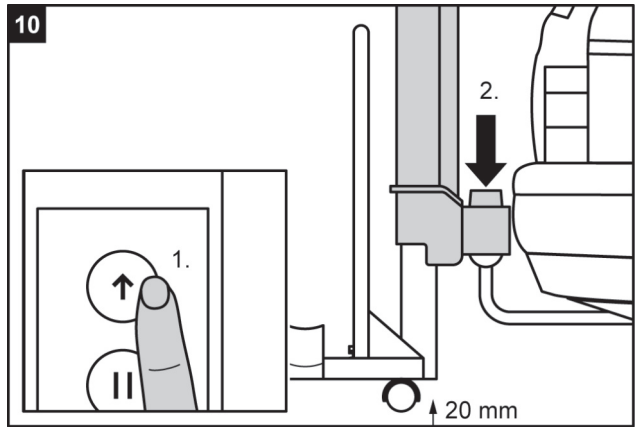
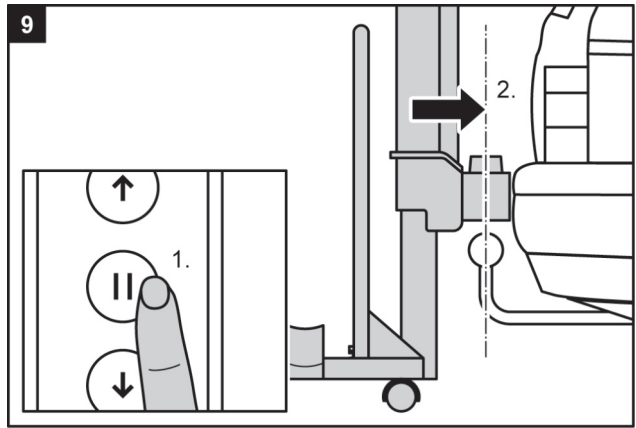
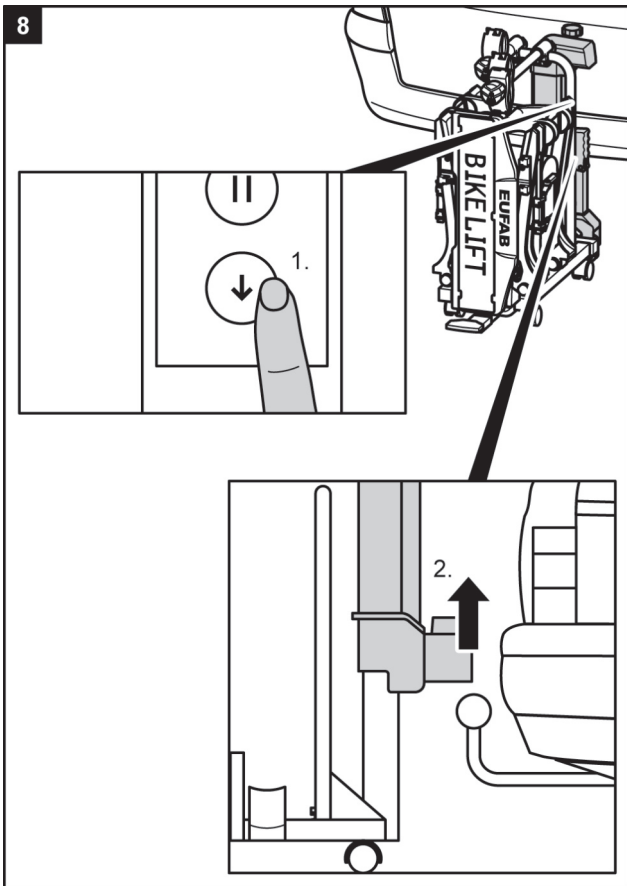
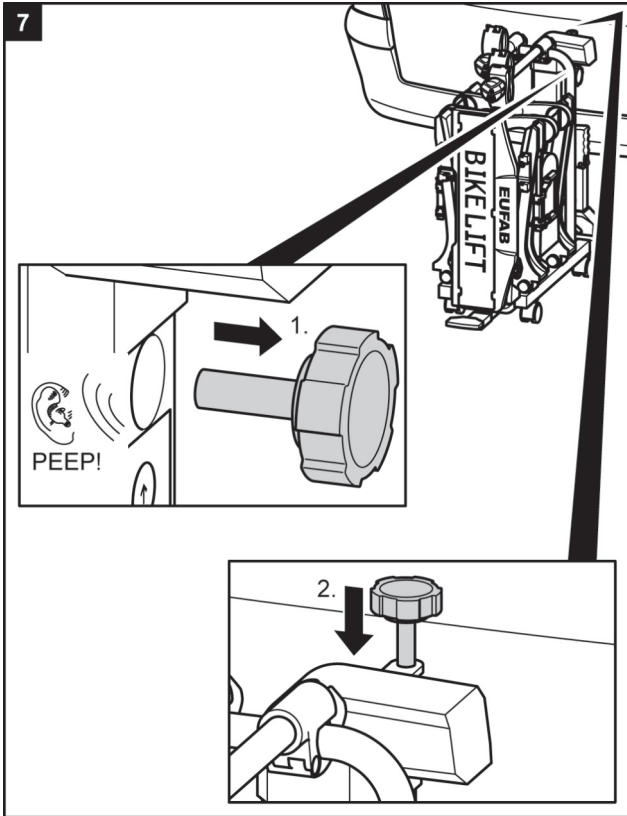

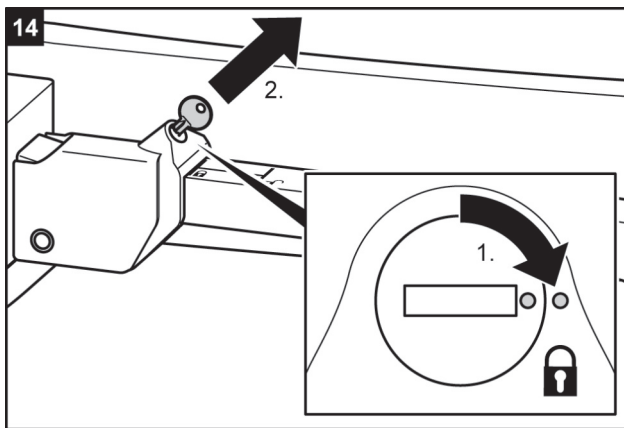
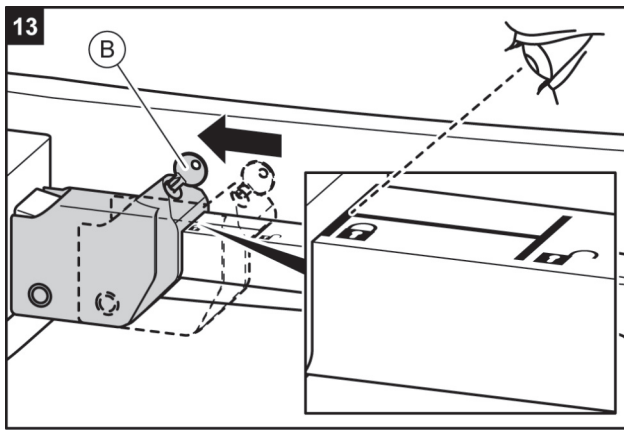

WARNING

If the lever is not locked to secure it, the bicycle carrier could become detached from the vehicle during the journey.

Injury to people or damage to property due to unsecured bicycle carrier.

- ⇒ Lock the bicycle carrier.
- ⇒ Check that you have locked the lever and removed the key.

Locking also prevents potential theft of the bicycle carrier.



WARNING

A loose connection between the carrier and the tow hitch can cause the bicycle carrier to become detached.

Injury to people or damage to property due to loss of the bicycle carrier during the journey.

- ⇒ Check that the bicycle carrier is fixed securely.
- ⇒ If the connection is loose, repeat steps 1 to 14. If no improvement occurs, the quick-release mechanism may require adjustment; see the chapter on Maintenance.

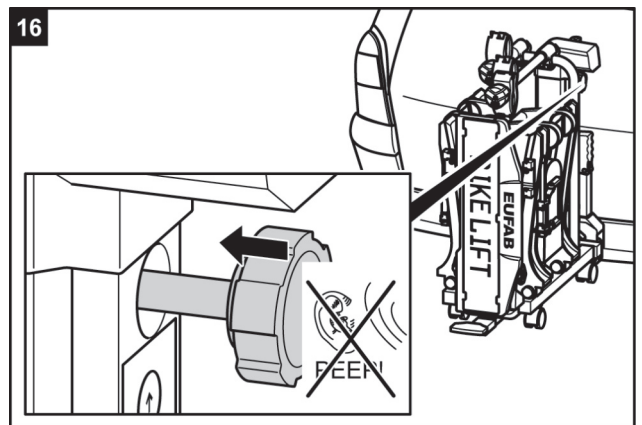
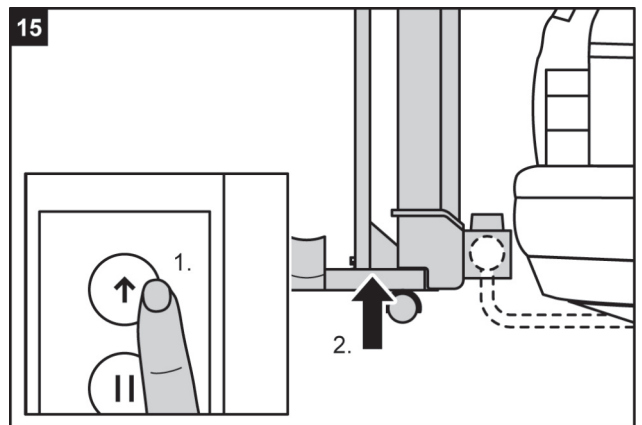

- ⇒ From the following step, the fitting sequence is identical for manual and automatic lifting.

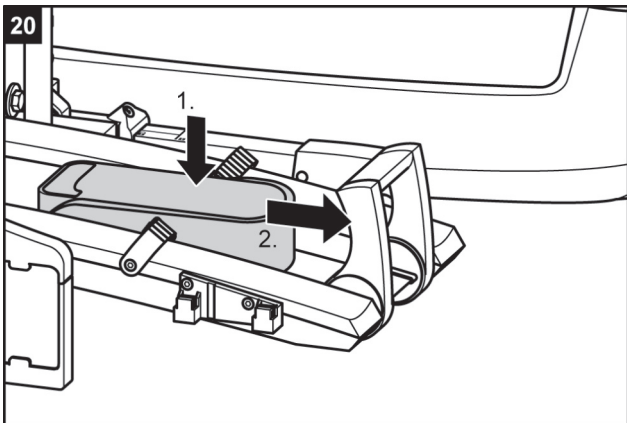
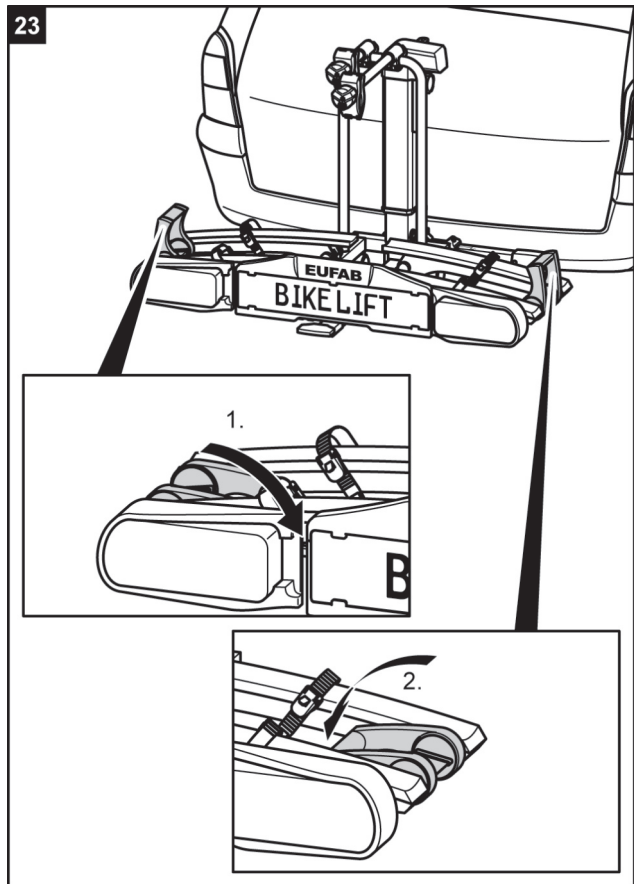
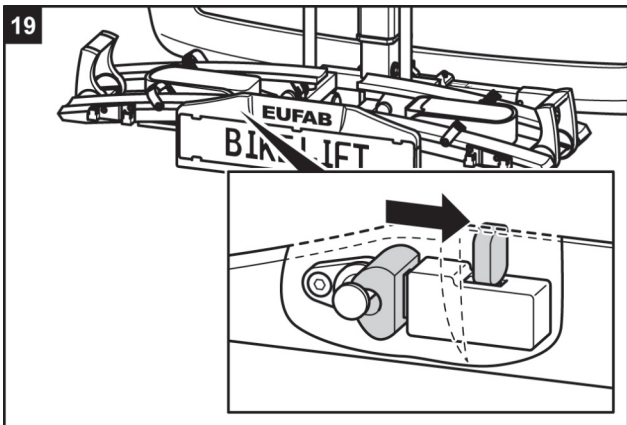
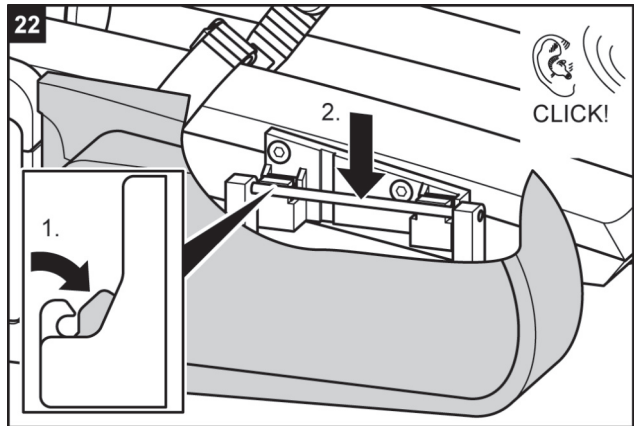
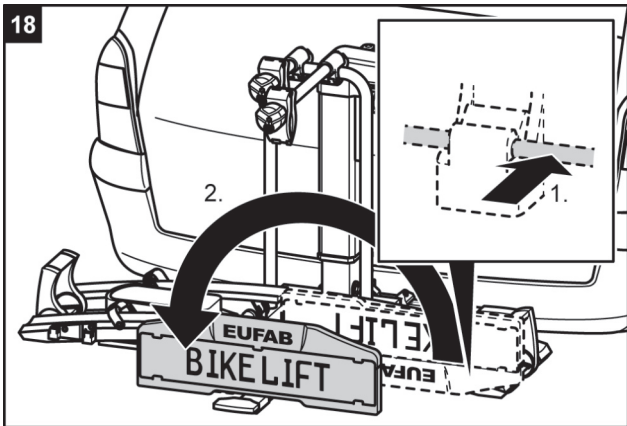
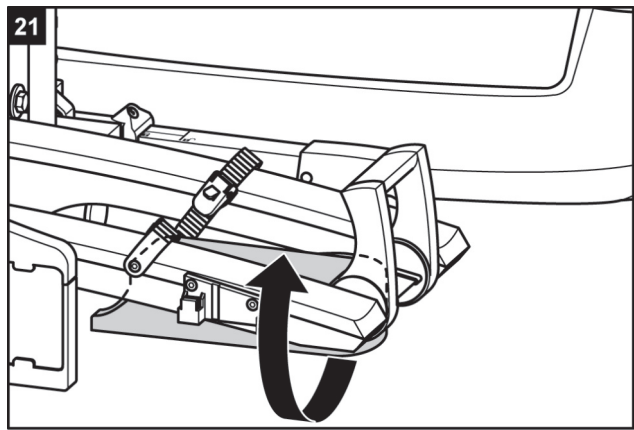
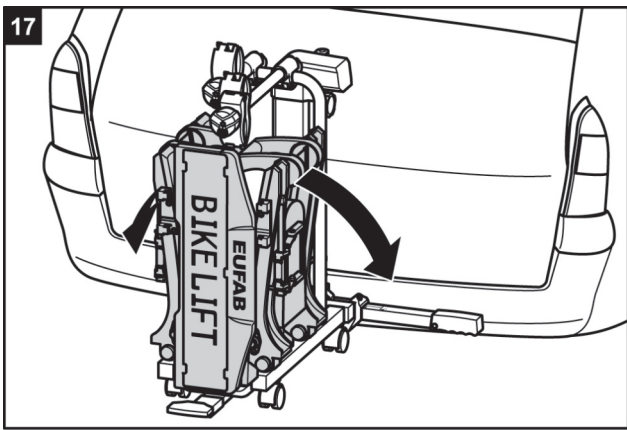



WARNING

Driving without a working lighting system can cause accidents.

Injury to people due to not being seen by other road users.

- ⇒ Before beginning each journey, check that the lighting system is working correctly.
- ⇒ Replace any defective bulbs.
- ⇒ Check the connection between the plug and the coupling.

Lowering and Raising the Bicycle Carrier

Lowering the Bicycle Carrier



WARNING

An unraised or unsecured bicycle carrier can become caught on obstacles.

Injury to people or damage to property due to loss of the bicycle carrier during the journey.

- ⇒ Raise the bicycle carrier to the end position before each journey.
- ⇒ Ensure that you secure the bicycle carrier with the locking pin, as described under "Raising the Bicycle Carrier".



CAUTION

Body parts or objects that are under the carrier when it is lowered may be crushed.

Injury to people or damage to property due to lowering the carrier.

- ⇒ Ensure that there is nothing under the carrier.
- ⇒ Watch out for your body; maintain a safe distance.

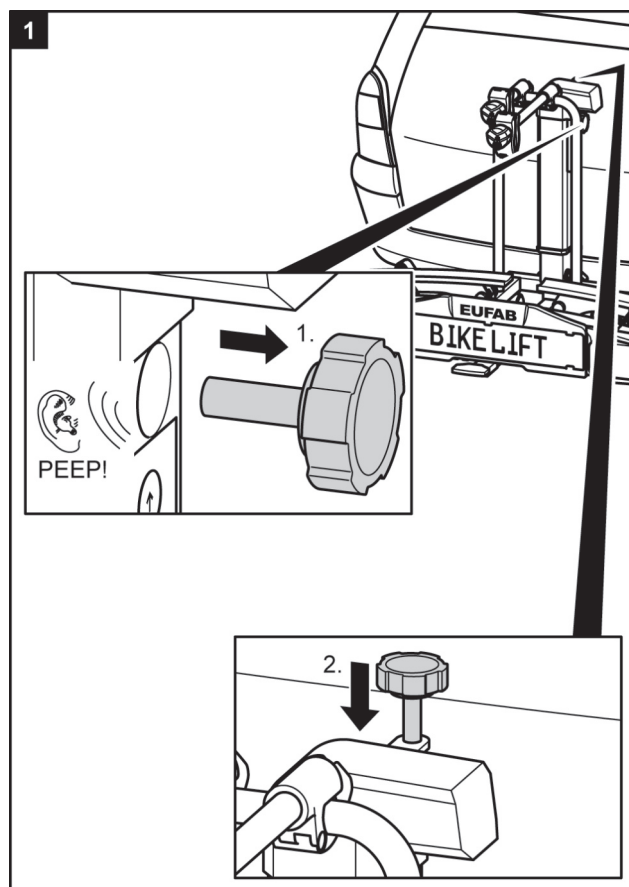

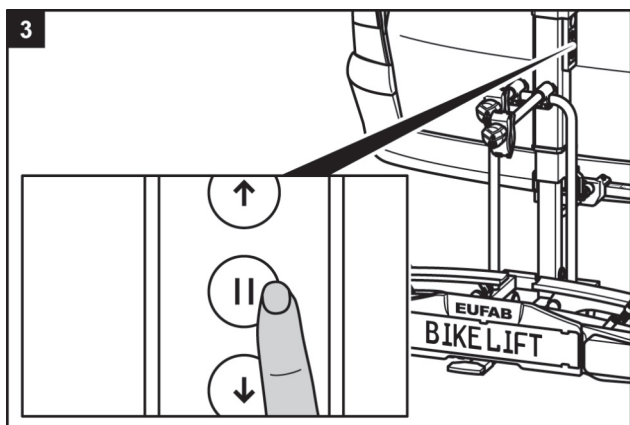
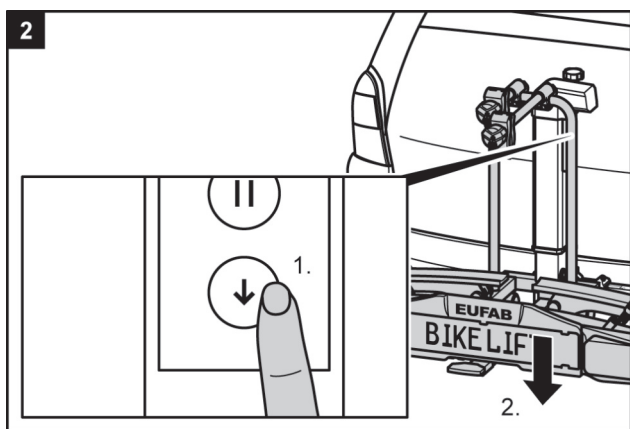

Raising and Securing the Bicycle Carrier

- ⇒ Raise the bicycle carrier until it stops.
- ⇒ Fit the locking pin.
 - The pin can be fitted only if the bicycle carrier is in the top end position.
- ⇒ The warning tone stops after the locking pin is fitted.



WARNING

Lowering the carrier during the journey can cause serious accidents

Injury to people or damage to property due to lowering the carrier during the journey.

- ⇒ Ensure that the locking pin is screwed in fully after raising.
- ⇒ If the pin is not screwed in fully at the beginning of the journey then a warning tone sounds.
- ⇒ If necessary, undo the locking pin again, raise the bicycle carrier until it stops, then screw in the locking pin fully.

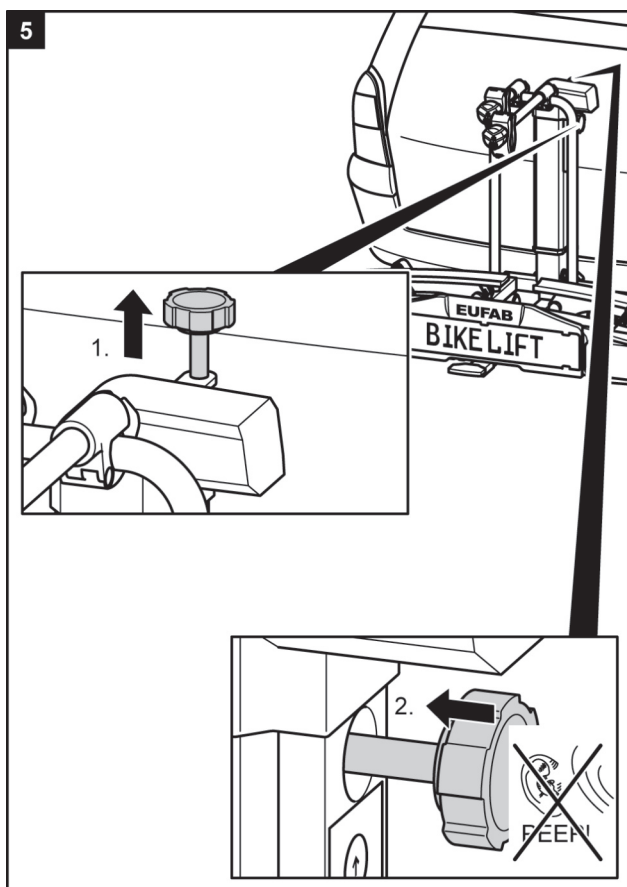
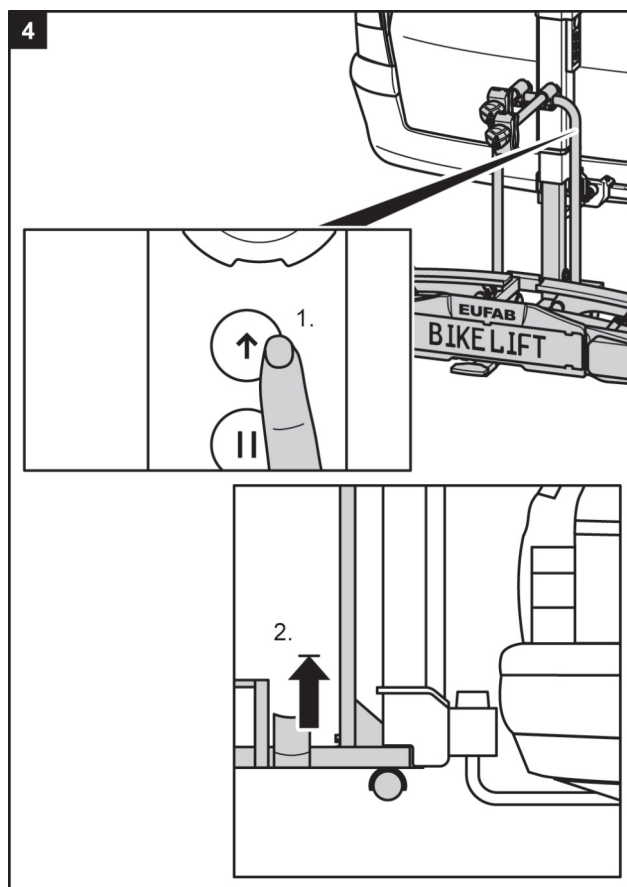

Attaching Bicycles

⇒ Start by lowering the holding area for the bicycles, as described in the chapter on “Lowering the Bicycle Carrier”.



NOTE

In rare cases it might not be possible to extend the bike carrier sufficiently as described in step 9 so that it can be pushed over the ball hitch of towing device. In this case, please tilt the bike carrier partway down to achieve the necessary coupling height.



WARNING

Parts on the bicycles that are not screwed on securely can become detached during the journey.

Injury to people or damage to property is possible due to parts flying around.

⇒ Remove all parts that are not securely connected to the bicycle, e.g. air pumps, panniers, navigation devices or batteries.

⇒ Also remove all parts that generate additional resistance, e.g. such as luggage baskets and child seats.



NOTE

To improve the handling of your vehicle, it is best to fit the heaviest bicycle first. Also, if you are fitting only one bicycle, you should place the bicycle in the rail that is closest to the rear of the vehicle.

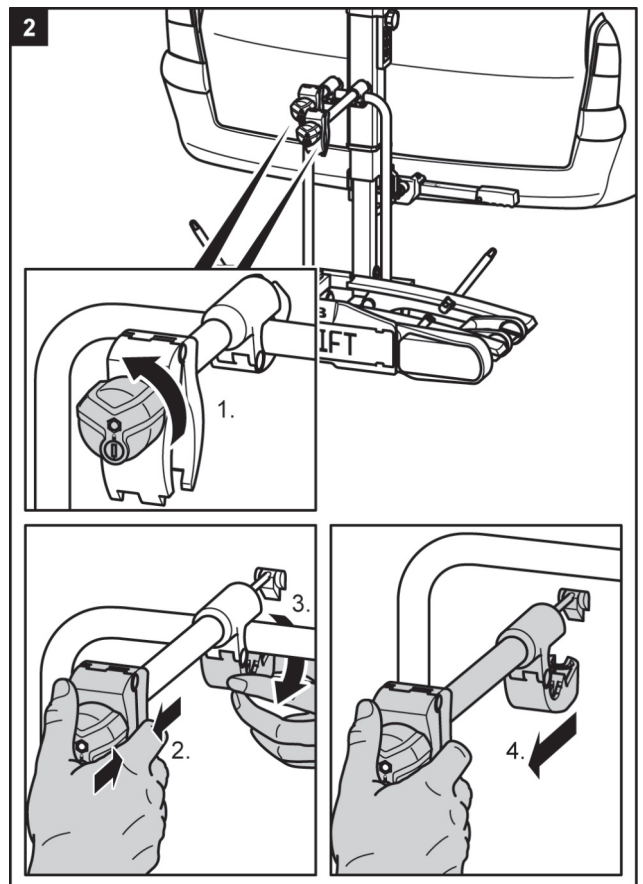
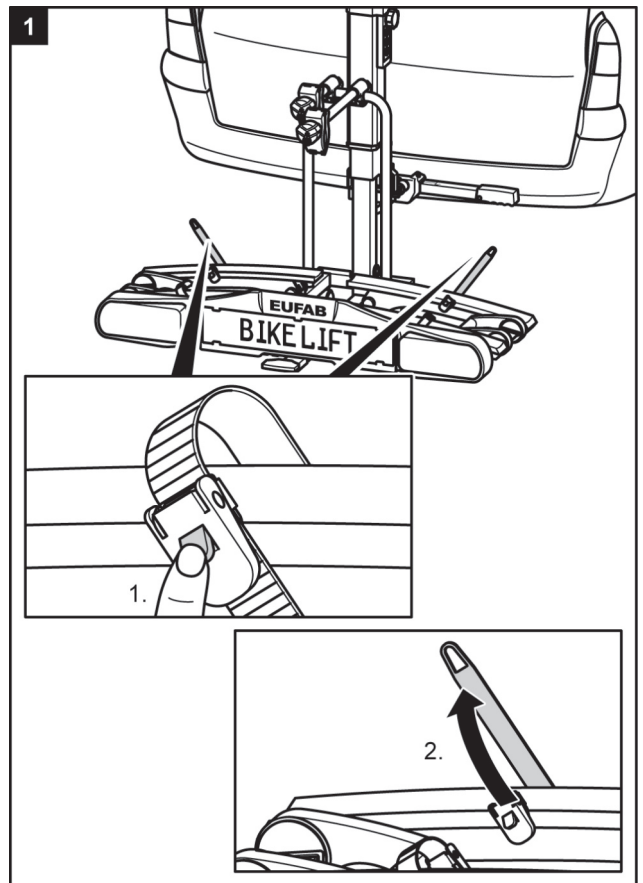

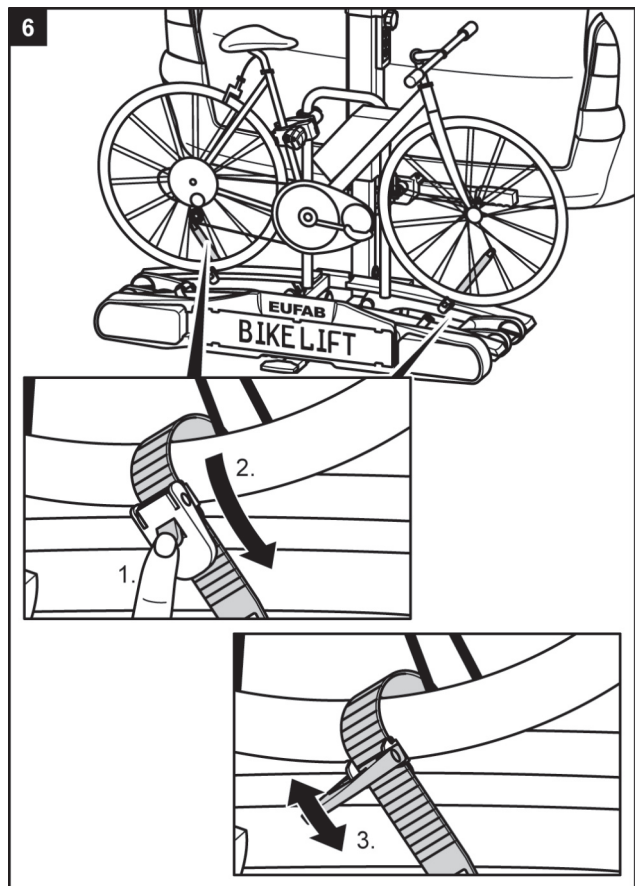
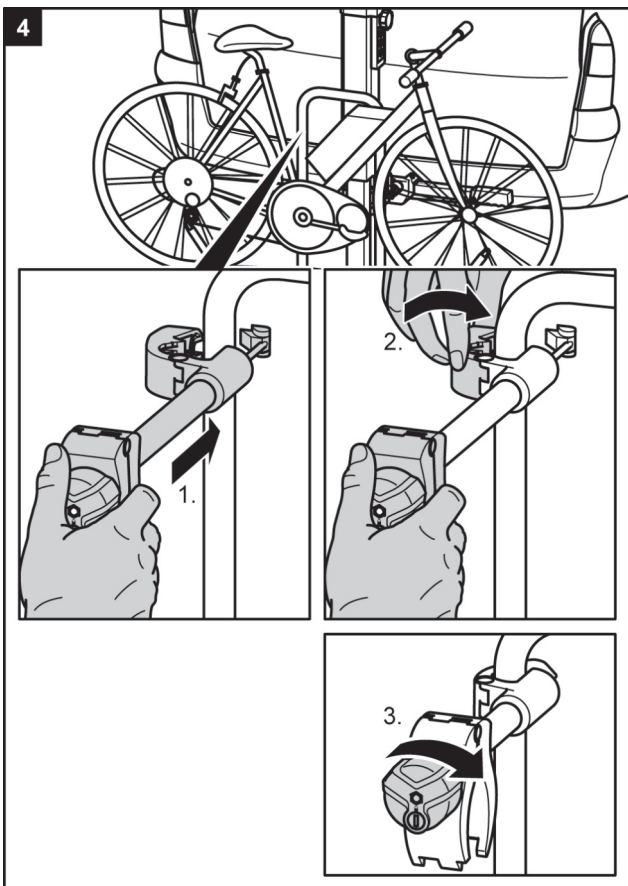
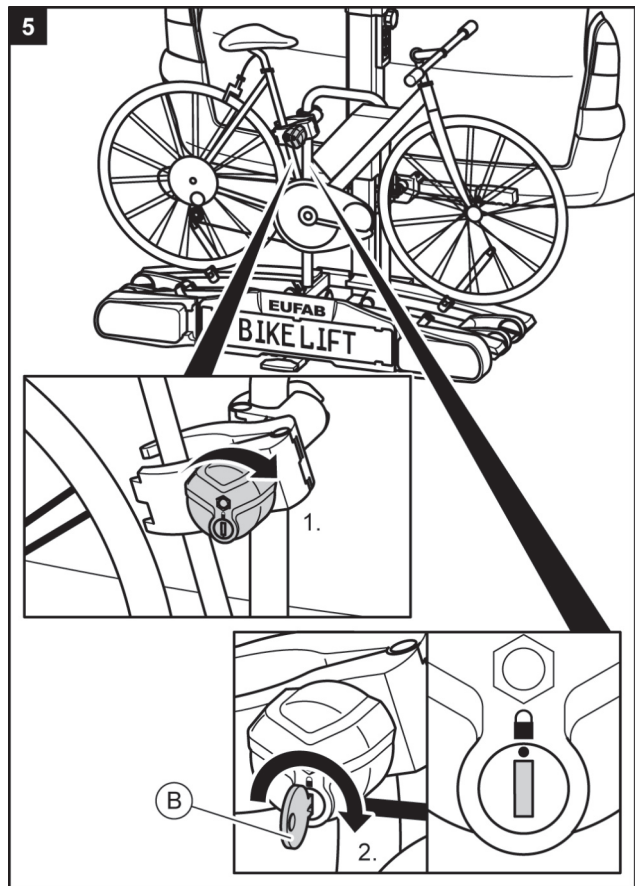
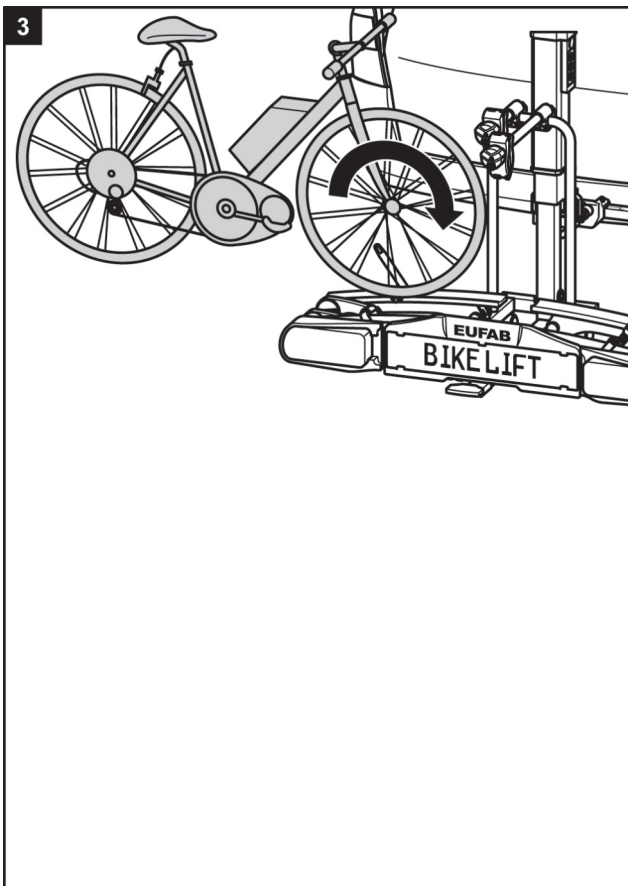

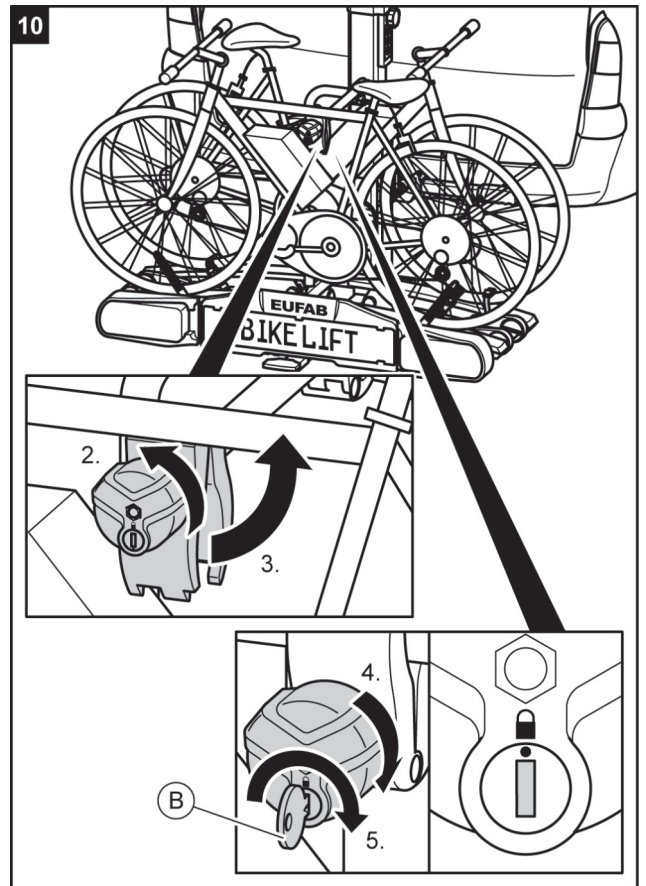
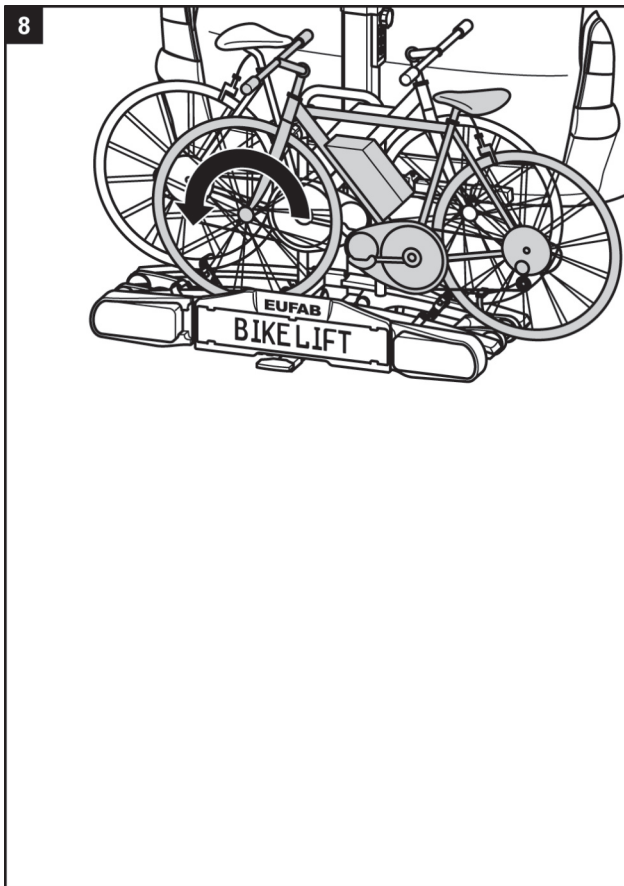
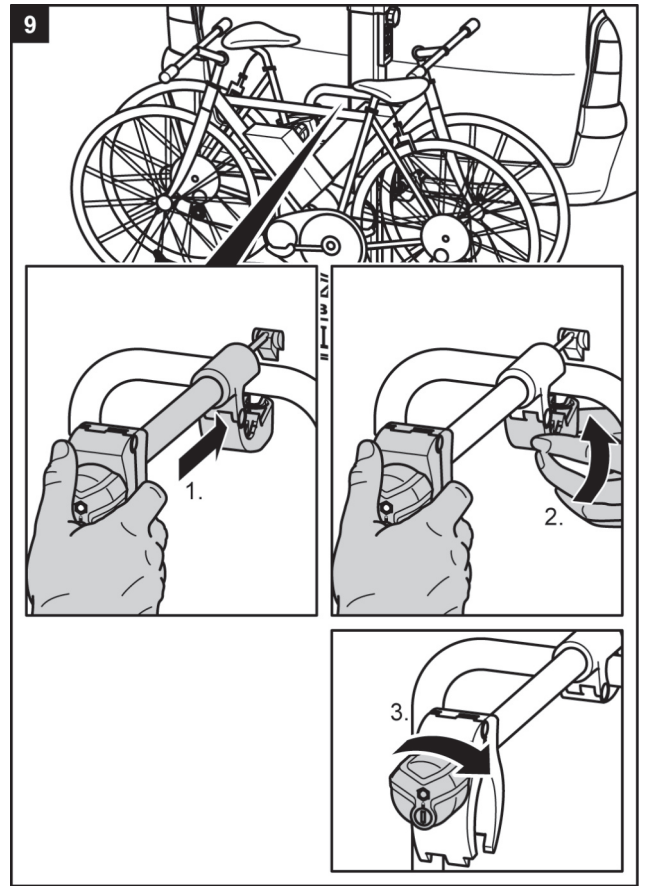
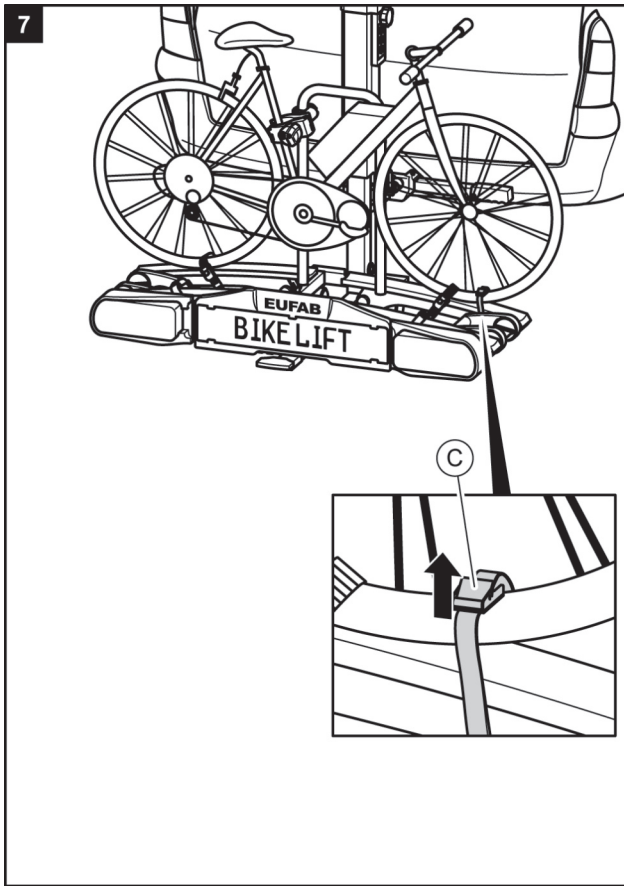

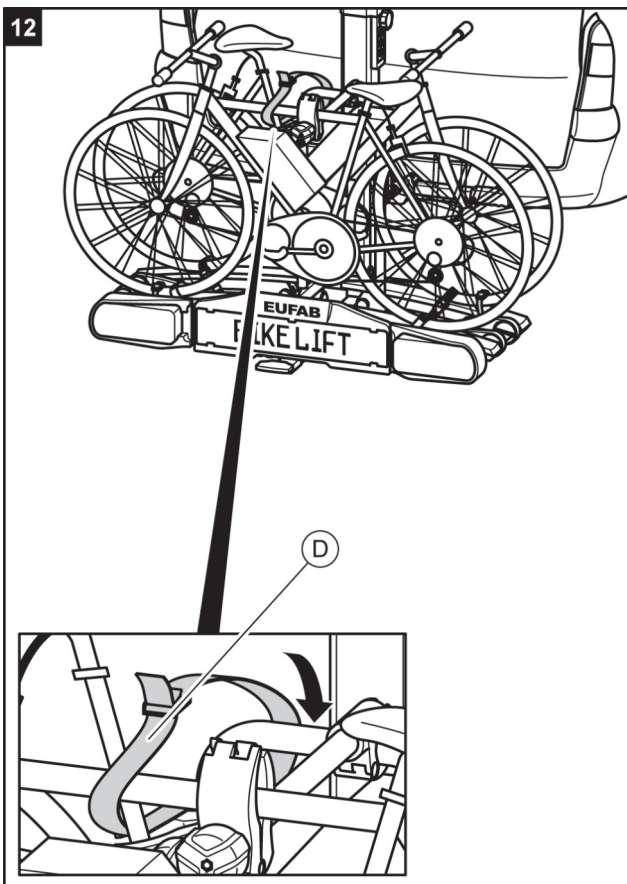
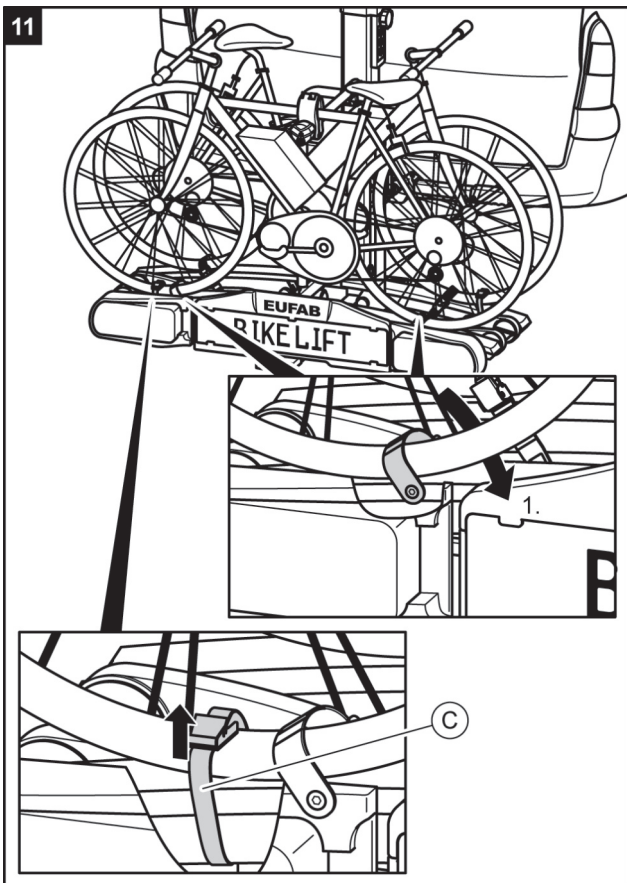

WARNING

Travelling without safety belts can cause accidents.

Injury to people or damage to property due to loss of the bicycles.

- ⇒ Before beginning each journey, check that the belt around the bicycles and the carrier U-bracket is sitting correctly and securely, see step 12 in this chapter.
- ⇒ Before beginning each journey, check that both belts around the front wheel and the belt around the back wheel of the bicycle are sitting correctly and securely
- ⇒ Retighten the belts if necessary.
- ⇒ Before beginning each journey, check that the belts used are undamaged and unworn
- ⇒ Replace damaged or worn belts with undamaged belts before beginning the journey. Use only belts that are approved by EAL GmbH for the purpose.



WARNING

A loose connection between the carrier and the bicycle can cause the connection to become detached and loss of the bicycle.

Injury to people or damage to property due to loss of a bicycle during the journey.

- ⇒ Check that the bicycles are fixed securely and fully.
- ⇒ If the connection is loose, repeat steps 1 to 12 from this chapter.

⇒ Now raise the bicycle carrier as described in the chapter on “Raising the Bicycle Carrier”.



WARNING

An unraised or unsecured bicycle carrier can become caught on obstacles.

Injury to people or damage to property due to loss of the bicycle carrier during the journey.

- ⇒ Raise the bicycle carrier to the end position before each journey.
- ⇒ Ensure that you secure the bicycle carrier with the locking pin, as described under “Raising the Bicycle Carrier”.

Tilting the Bicycle Carrier, Access to the Boot

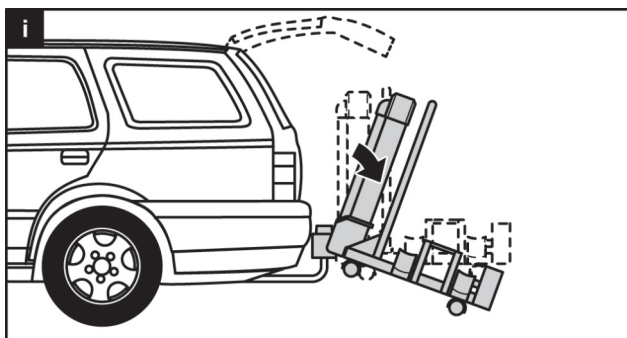

CAUTION

The boot lid could hit the bicycle carrier and be damaged.

Damage to property due to boot lid opening.

- ⇒ Switch off electric boot lids and operate manually.
- ⇒ Fold down the bicycle carrier before opening the boot lid.



CAUTION

Injury to people or damage to property due to sudden folding down.

Body parts or objects that are under or in front of the carrier when it is folded down may be crushed.

- ⇒ Ensure that there is nothing under the carrier.
- ⇒ Watch out for your body and particularly your head; maintain a safe distance.
- ⇒ Release the lock (1.). Hold the carrier on the U-bracket when folding down (2.). Release the lock with a foot (3.) and tilt the carrier down with a hand.

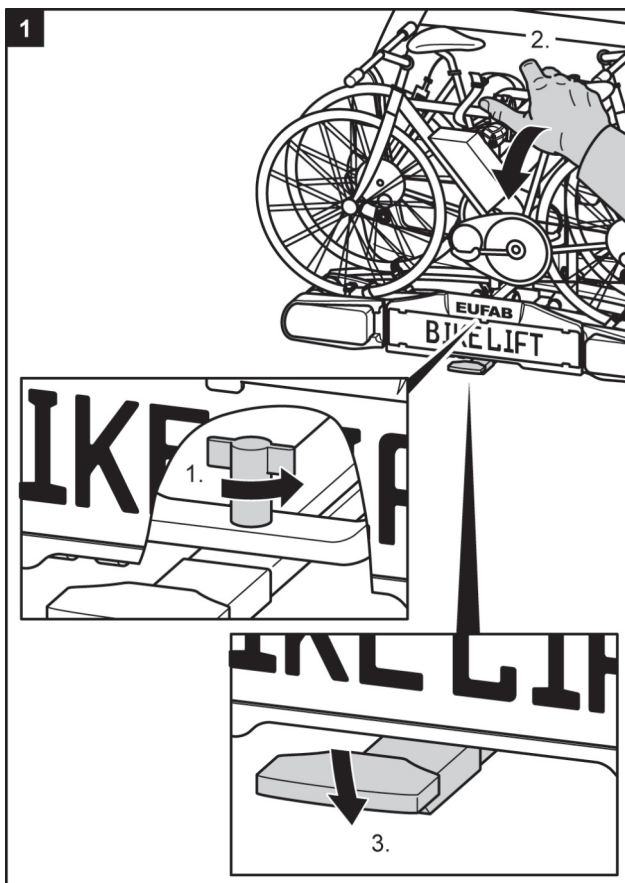

CAUTION

Injury to people or damage to property possible by folding up.

Body parts or objects that are between the carrier and the vehicle may be crushed.

- ⇒ Ensure that there is nothing between the carrier and the vehicle.
- ⇒ Remove everything from the space between the carrier and the vehicle.

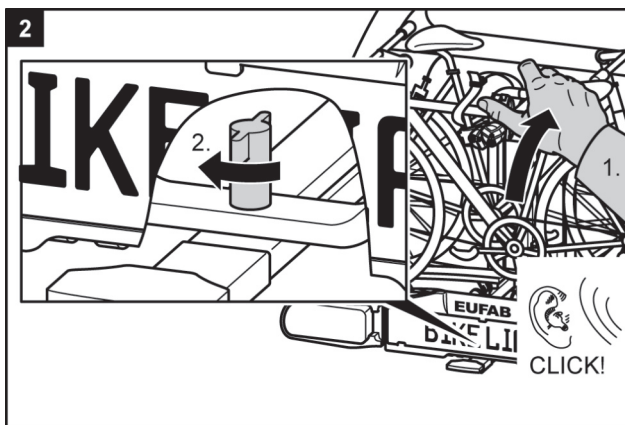



WARNING

A bicycle carrier that is not folded up can cause the carrier or coupling to break off.
Injury to people or damage to property due to loss of the bicycle carrier during the journey.

- ⇒ Fold up the carrier before the journey.
- ⇒ Check that the bicycle carrier is engaged properly. If necessary, engage the carrier as described previously.

Removing the Bicycle Carrier

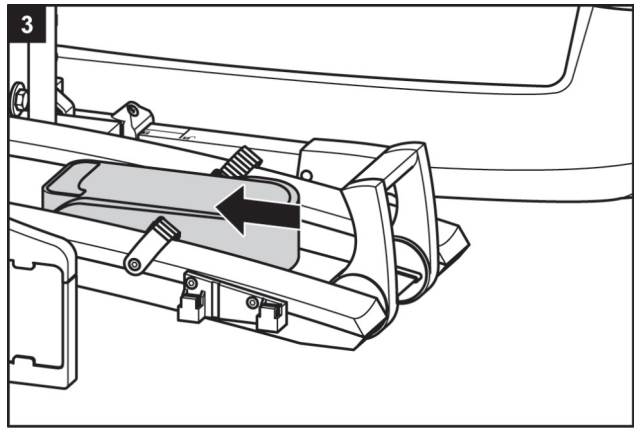
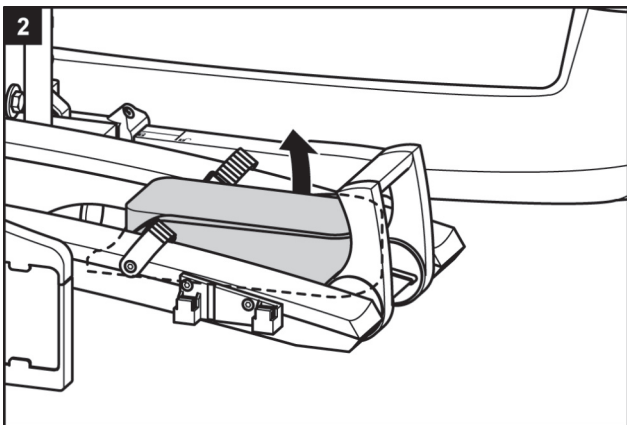
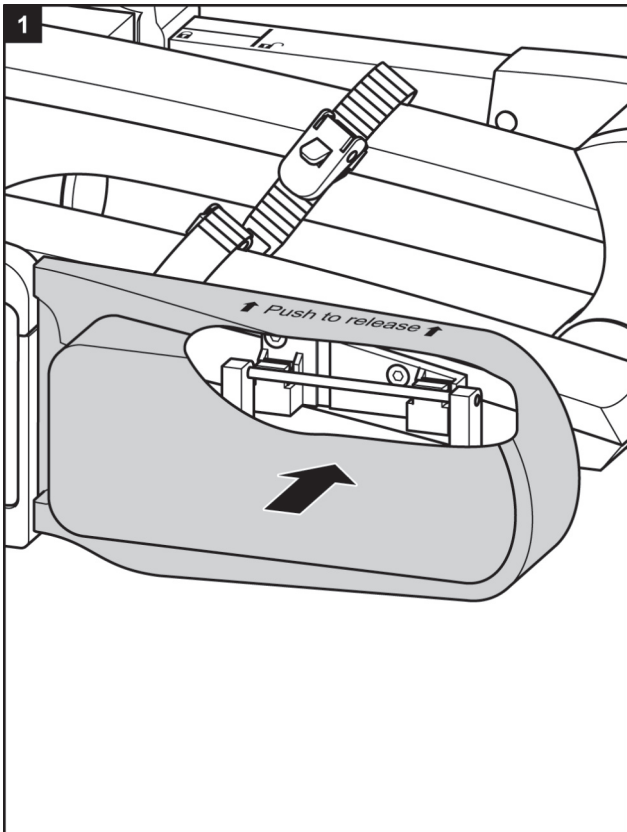

- ⇒ Start by undoing the locking bolt behind the number plate holder.

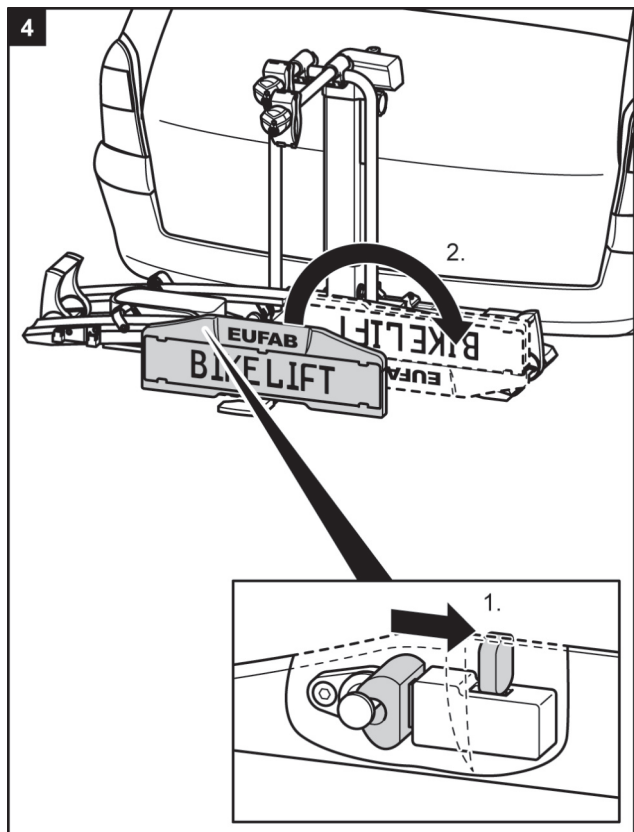

- ⇒ Then, when removing the bicycle carrier, proceed in reverse order of fitting.

Carrying the Bicycle Carrier

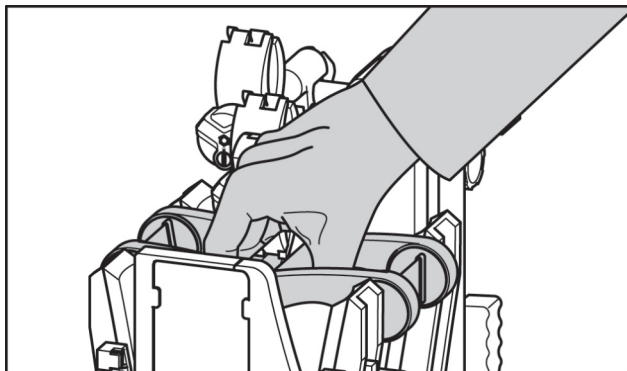

Rolling the Bicycle Carrier

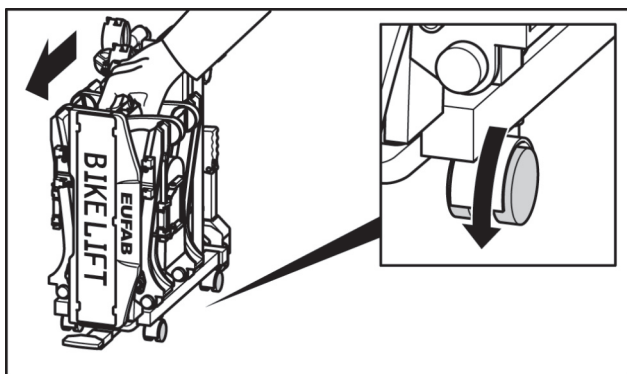

Storing the Bicycle Carrier in the Protective Cover

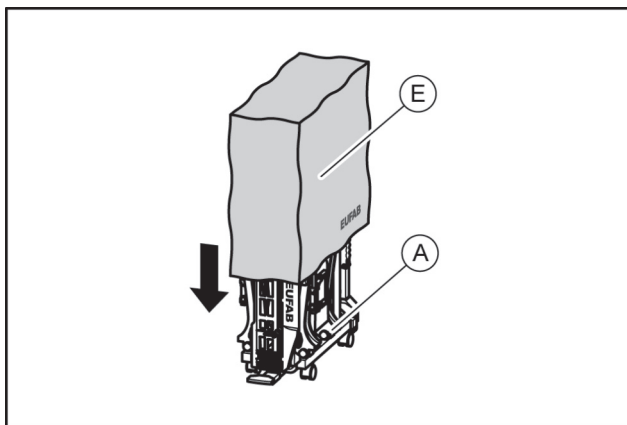

Cleaning and Care

The bicycle carrier can be cleaned with a mild detergent, warm water, and/or a soft cloth. Remove coarse dirt and dust in advance. Do not use solvents or similar cleaners, as these could damage the bicycle carrier.

Allow the bicycle carrier to dry by itself. Do not use a hairdryer or other heated appliances to speed up the drying process. Clean the bicycle carrier regularly in coastal areas and in the case of use in winter conditions, to rinse off salt and prolong the life of the bicycle carrier.

In prolonged periods without use (e.g. over winter), store the bicycle carrier in a place that is dry and protected, to prolong its life.

Maintenance

Before each journey, check the bicycle carrier for wear. Defective metal parts and tension belts in particular must be replaced.

To replace the parts, contact our customer service.

Any change to original parts and materials or to the structure of the bicycle carrier may impair safety and performance.

The steel parts of the bicycle carrier have been protected from corrosion by powder coating in the factory. If this layer of paint is damaged, ensure that the damage is rectified professionally as soon as possible.

Under normal conditions, the bicycle carrier requires only cleaning and is otherwise maintenance-free.

Adjusting the quick-release mechanism

Perform this maintenance only if the bicycle carrier cannot be fitted firmly on the tow hitch as described in the chapter on Fitting.

- ⇒ Remove the bicycle carrier from the tow hitch, as described under Removal.
- ⇒ Pull off the protective dust cap.
- ⇒ Loosen the locknut a little, as shown in the illustration.
- ⇒ Tighten the adjusting screw by a quarter turn.
- ⇒ Tighten the locknut.
- ⇒ Check that the carrier is now sitting firmly on the tow hitch, as described under Fitting. If not, repeat the steps described above.

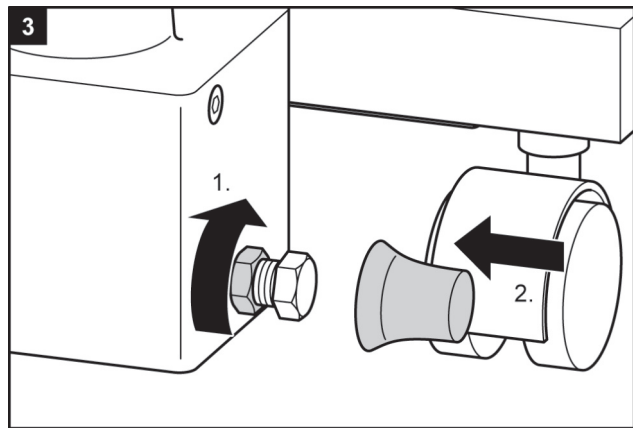
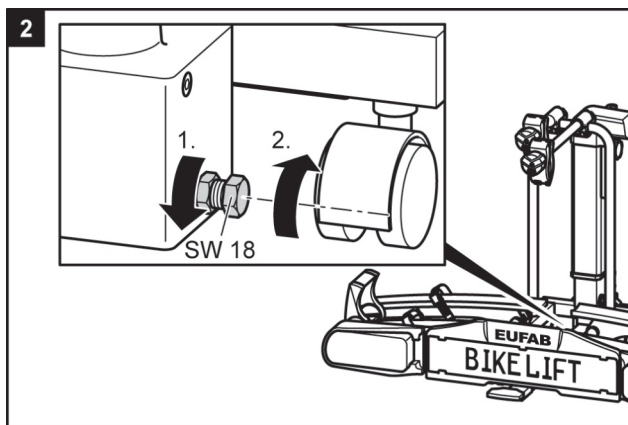
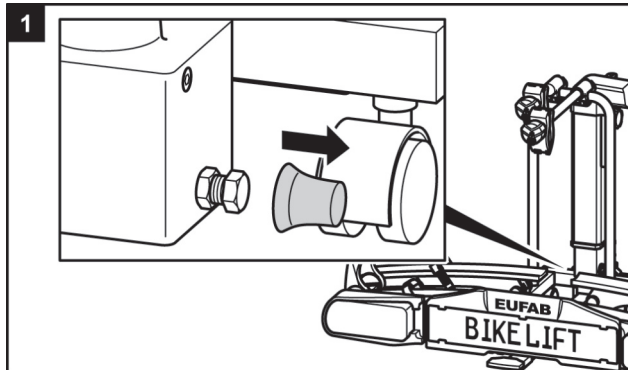

Disposal

Observe the local official regulations for disposal.

Also, dispose of the packaging by type in the collection containers provided for this.

More information can be obtained from your local waste disposal centre.

Contact

EAL GmbH
Otto-Hausmann-Ring 107
42115 Wuppertal
GERMANY

Telephone: +49 (0) 202 - 429283-0

Fax: +49 (0) 202 - 429283-20

Email: info@eal-vertrieb.com

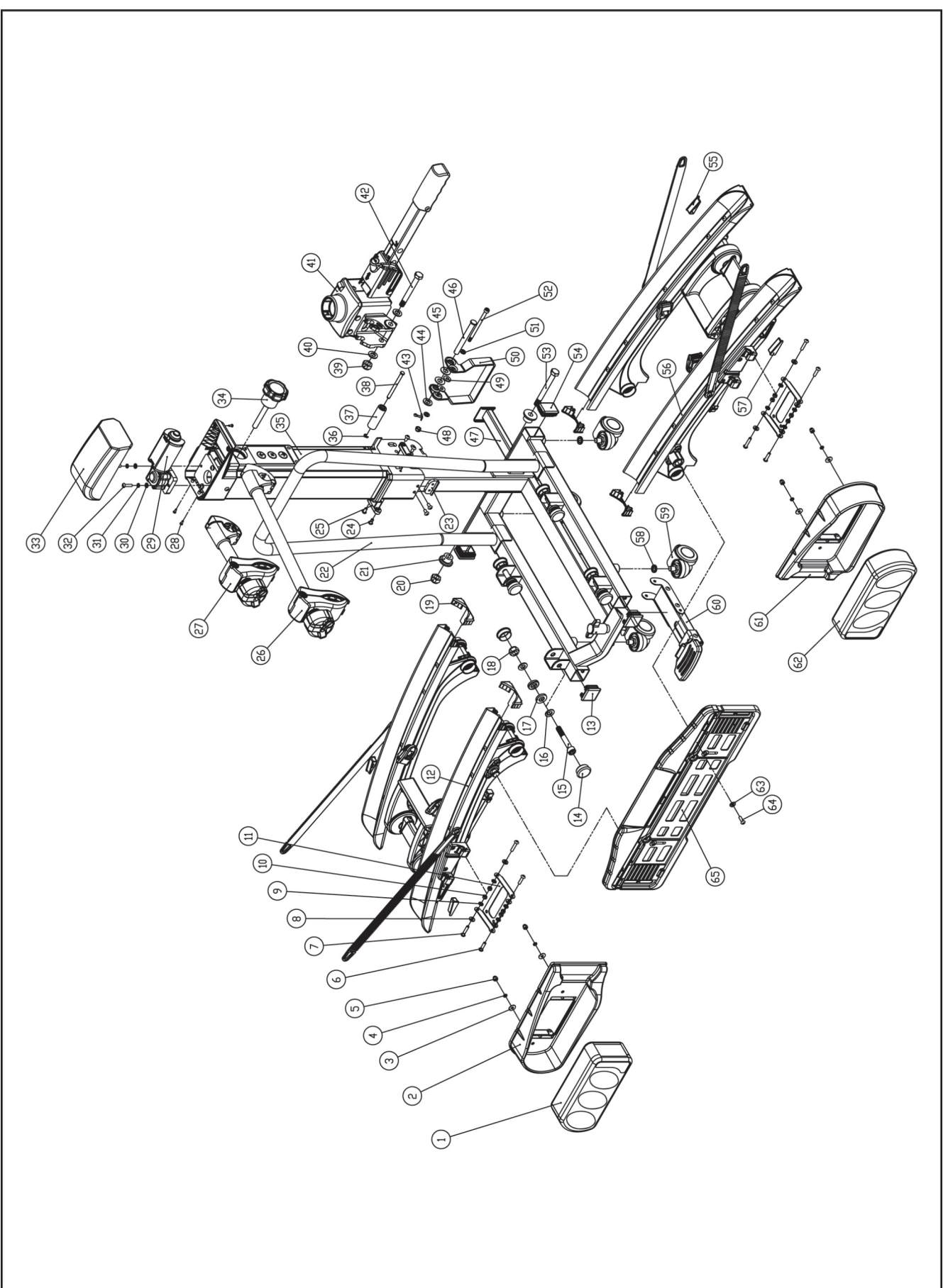

Pos.	Menge	Bezeichnung
1	1	Lamp complete right
2	1	Lamp guard right
3	4	Washer M5
4	4	Spring washer M5
5	4	Capped nut M5
6	4	Screw M5X20
7	4	Screw M5X25
8	8	Nylon washer M5
9	8	Washer M5
10	8	Self-locking nut M5
11	2	Lamp countersink
12	1	Left wheel rail with tension belt and carrier handle
13	2	Stopper for Nr.22,35X35mm
14	8	Round stopper for Nr.12
15	4	Bolt M10X65
16	8	Washer M10
17	8	Nylon washer M10
18	4	Self-locking nut M10
19	4	End cap aluminium rail interior
20	1	Self-locking nut M10
21	2	Stopper bearing pad
22	1	Carrier table bracket and U-bracket
23	1	Small plastic stopper 1
24	6	Screw M5X10
25	2	Small plastic stopper 2
26	1	Lock bracket long
27	1	Lock bracket short
28	4	Screw ST 2.9X9.5
29	1	Motor
30	2	Washer M5
31	2	Spring washer M5
32	2	Screw M5X20
33	1	Plastic cover for lift bracket

Pos.	Menge	Bezeichnung
34	1	Safety pin
35	1	Lift bracket
36	1	Jump ring
37	1	Nylon roller
38	1	Pin ø6
39	1	Self-locking nut M10
40	2	Washer M10-2.0
41	1	quick release
42	1	Bolt M10X87
43	1	Split pin ø3.2X25
44	2	Washer M10-2.0
45	2	Big washer M10-1.2
46	1	Pin ø10
47	1	Push rod
48	1	Self-locking nut M6
49	2	Big washer M6-1.2
50	1	Tilting operator
51	2	Washer M6-1.6
52	1	Bolt M6X85
53	1	Bolt M10X95
54	2	Stopper for Nr.22,30X40mm
55	2	Triangle end cap 1
56	1	right wheel rail with tension belt and carrier handle
57	2	Triangle end cap 2
58	4	Spring washer M10
59	4	Universal castor
60	1	Kick plate for locking mechanism
61	1	Lamp guard left
62	1	Lamp complete left
63	1	Nylon washer M5
64	1	Screw M5X16
65	1	Registration plate bracket

Pin Assignment

The bicycle carrier is equipped with a lighting system. This is connected to the tow hitch socket with a 13-pole plug. If your vehicle has only a 7-pole rather than a 13-pole connection, the corresponding assignments are specified here. This information is intended only for conversion by a specialist company. Conversion by an unqualified person is not permitted.

13 Pin

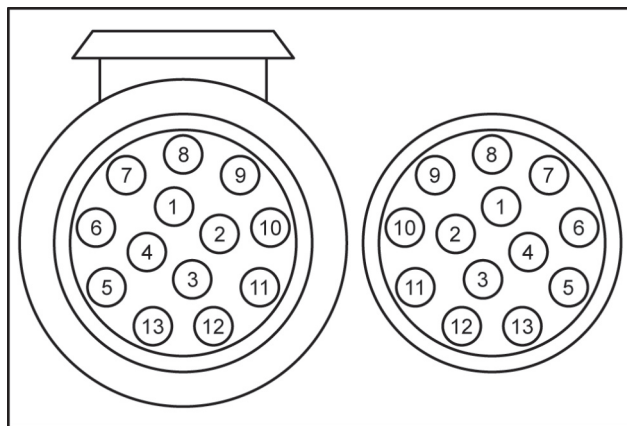

1	Left indicator	Yellow
2	Rear fog light	Blue
3	Mass	White
4	Right indicator	Green
5	Right tail light	Brown
6	Brake lights	Red
7	Left tail light	Black
8	Reversing light	Grey
9	+12 V for lift system	Red
10	Not used	–
11	Not used	–
12	Not used	–
13	0 mass for lift system	Black

Portevélo Bike Lift

Manuel de l'opérateur

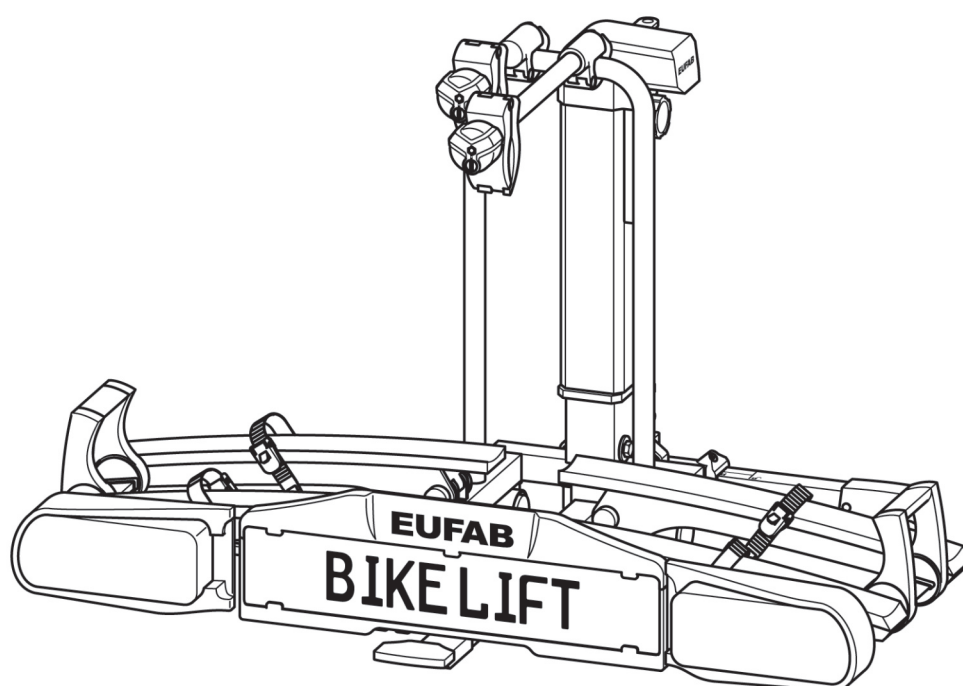

Bike Lift
Réf. 11535

Contenu

Indications concernant les instructions d'utilisation.....	51
Préface.....	51
Obligations relatives à ces instructions d'utilisation.....	51
Utilisation conforme.....	51
Explication des consignes de sécurité.....	51
Contenu de livraison.....	52
Caractéristiques techniques.....	52
Conditions pour l'accouplement.....	52
Consignes de sécurité.....	53
Avant la première mise en service.....	54
Montage de la plaque d'immatriculation sur le porte-vélo.....	54
Montage et utilisation.....	55
Montage du porte-vélo sur l'accouplement de remorque.....	55
Soulever le porte-vélo sur l'accouplement de remorque à la main.....	56
Soulever le porte-vélo sur l'accouplement de remorque avec le moteur incorporé.....	57
Abaisser et soulever le porte-vélo.....	60
Abaisser le porte-vélo.....	60
Soulever et sécurisez le porte-vélo.....	61
Fixation des vélos.....	62
Basculer le porte-vélo, accès au coffre.....	66
Démontage du porte-vélo.....	67
Porter et ranger.....	68
Nettoyage et entretien.....	68
Maintenance.....	69
Élimination.....	69
Contact.....	69
Annexe.....	70
Vue d'ensemble des pièces de rechange (vue éclatée).....	70
Vue d'ensemble des pièces de rechange (tableau).....	71
Affectation de connecteur, 13 Pin.....	72

Indications concernant les instructions d'utilisation

Préface

Ces instructions d'utilisation vous permettent une utilisation

- conforme et
- sûre

du porte-vélo Bike Lift.

Obligations relatives à ces instructions d'utilisation

Toute personne qui

- monte,
- nettoie ou
- élimine

ce porte-vélo doit avoir pris connaissance et compris l'intégralité de ces instructions d'utilisation.

Conservez toujours les instructions d'utilisation à portée de main. Si vous donnez ce porte-vélo, transmettez également ces instructions d'utilisation.

Utilisation conforme

Le porte-vélo Bike Lift sert au transport de max. deux vélos. Il ne peut être monté que sur un accouplement de remorque qui remplit les conditions décrites dans le chapitre Conditions pour l'accouplement.

De plus, la charge utile autorisée du porte-vélo ne peut en aucun cas être excédée. Pour une utilisation conforme, il convient de respecter toutes les informations dans ces instructions de montage, en particulier les consignes de sécurité. Toute autre utilisation est considérée comme non conforme et peut causer des dommages corporels ou matériels. EAL GmbH n'endosse aucune responsabilité pour des dommages survenus suite à une utilisation non conforme.

Explication des consignes de sécurité

Vous trouverez dans l'explication les catégories de consignes de sécurité suivantes :



DANGER

Une remarque avec le signal DANGER vous prévient d'un danger à haut risque. S'il n'est pas évité, vous risquez la mort ou de graves blessures.



AVERTISSEMENT

Une remarque avec le signal AVERTISSEMENT vous prévient d'une menace à moyen risque. S'il n'est pas évité, vous risquez la mort ou de graves blessures.



PRUDENCE

Une remarque avec le signal PRUDENCE vous prévient d'un danger à bas risque. S'il n'est pas évité, vous risquez des blessures bénignes ou modérées.



ATTENTION

Une remarque avec le signal ATTENTION vous prévient d'un risque de dommage matériel. S'il n'est pas évité, le produit ou quelque chose dans son entourage peut être endommagé.



REMARQUE

Autre remarque :
Conseil utile. Facilite le fonctionnement ou le montage du produit ou sert à une meilleure compréhension.

Le symbole de sécurité utilisé ne remplace pas le texte de consigne de sécurité.

Lisez donc les consignes de sécurité et respectez-les !

Contenu de livraison

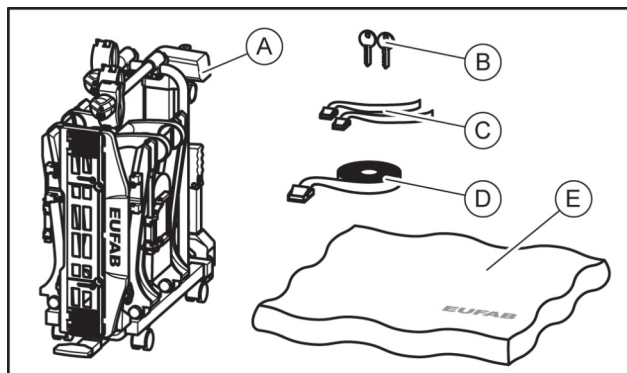

- A = porte-vélo
- B = 2 clés
- C = 2 sangles de sécurité pour roues avant
- D = 1 sangle de sécurité pour cadre de vélo
- E = housse de protection

Caractéristiques techniques

Matériau :	Aluminium Acier Plastique
Poids net :	25 kg
Charge utile max.:	60 kg
Consommation électrique, moyenne :	2 A
Consommation électrique, max.:	5,5 A
Dimensions (LxHxL), min.:	30 × 74 × 74 cm
Dimensions (LxHxL), max. :	135 × 74 × 74 cm
Taille emballage (LxHxL):	81 × 77 × 33 cm

Ne pas excéder la charge utile maximale du porte-vélo ni la charge d'appui autorisée de l'accouplement de remorque.

Ne pas excéder le poids net autorisé, ni la charge maximale à l'essieu autorisée du véhicule avec le porte-vélo ou le chargement.

Exemple pour Bike Lift

Charge d'appui max. accouplement de remorque	Porte-vélo poids net	Charge utile max. du porte-vélor
50 kg	25 kg	25 kg
60 kg	25 kg	35 kg
75 kg	25 kg	50 kg
90 kg	25 kg	max. 60 kg !

Conditions pour l'accouplement



DANGER

Possibles dommages corporels en cas de rupture de l'accouplement de remorque.

Si le porte-vélo est monté sur un accouplement en matière fragile, celui-ci peut se casser.

⇒ Ne montez le porte-vélo que sur un accouplement en acier St52, fonte grise GG52 ou un meilleur matériau.

⇒ Ne montez pas le porte-vélo sur un accouplement en aluminium, d'autres métaux légers ou en plastique.

Conditions pour l'accouplement

Ne montez le porte-vélo que sur des accouplements de remorque qui possèdent les caractéristiques suivantes :

Matériau : min. acier St52 ou fonte grise GG52

Valeur D : ≥ 7,6 kN

Respectez les consignes du fabricant d'accouplement.

Consignes de sécurité

Suivez les instructions de montage à la lettre. Si vous ne respectez pas ces instructions, cela peut occasionner des dommages corporels ou matériels. Si vous n'êtes pas sûr du montage, demandez à votre revendeur ou au fabricant pour d'autres informations.

Ni le fabricant ni le revendeur n'est responsable de dommages qui résultent d'une utilisation non conforme ou d'un montage incorrect.

Contrôler régulièrement le porte-vélo et le chargement ! Vous y êtes obligés par la loi et vous serez responsable en cas de dégâts.



REMARQUE

Il faut une licence d'exploitation européenne pour ce porte-vélo. Elle est fournie avec cet appareil et doit être à portée de main lors de l'utilisation de l'appareil.



REMARQUE

Lorsque vous conduisez avec le porte-vélo monté, les dispositions législatives et réglementaires s'appliquent au transport de sangles à l'arrière de votre véhicule.



AVERTISSEMENT

Le porte-vélo influence les caractéristiques de conduite de votre véhicule.

Dommages corporels ou matériels causés par un comportement différent du véhicule.

- ⇒ Adaptez votre vitesse au nouveau comportement du véhicule.
- ⇒ Ne roulez jamais au-dessus de 130 km/h.
- ⇒ Évitez les mouvements de direction brusques et par à-coup.
- ⇒ Tenez compte du fait que votre véhicule est plus long que d'habitude.



AVERTISSEMENT

Des pièces qui dépassent du véhicule ou du porte-vélo peuvent causer des dommages corporels ou matériels pendant le trajet.

Dommages corporels ou matériels causés par des pièces qui dépassent.

- ⇒ Ne montez que des pièces qui ne dépassent pas du véhicule.



AVERTISSEMENT

Dépasser la charge utile maximale du porte-vélo, ainsi que la charge d'appui autorisée de l'accouplement de remorque ou du poids net autorisé peut provoquer de graves accidents.

Dommages corporels ou matériels causés par une surcharge.

- ⇒ Respectez impérativement les indications concernant la charge utile max., la charge d'appui autorisée et le poids net autorisé de votre véhicule. Ne dépassez ces indications en aucun cas.



AVERTISSEMENT

Conduire sans sangle de sécurité peut provoquer des accidents.

Dommages corporels ou matériels causés par la perte de vélos.

- ⇒ Avant chaque départ, vérifiez que la sangle soit bien fixée aux vélos et à l'étrier en U du porte-vélo, voir chapitre « Monter les vélos ».
- ⇒ Avant chaque départ, vérifiez le bon positionnement des deux sangles sur la roue avant et arrière du vélo.
- ⇒ Resserrez les sangles si nécessaire.
- ⇒ Avant chaque départ, vérifiez que les sangles ne soient pas abimées ni usées.
- ⇒ Les sangles abimées ou usées doivent être remplacées par des sangles intactes avant le départ. Seules les sangles qui sont agréées par EAL peuvent être utilisées.



AVERTISSEMENT

Conduire avec un porte-vélo replié peut provoquer des accidents. Les parties mobiles du porte-vélo constituent une source de danger en condition non montée.

Dommages corporels ou matériels causés par un porte-vélo pas complètement monté.

- ⇒ Démontez le porte-vélo quand vous n'en avez pas besoin.
- ⇒ Ne roulez jamais avec un porte-vélo replié.



AVERTISSEMENT

Les bâches augmentent la résistance de l'air. Elles peuvent se desserrer et s'envoler, ce qui peut provoquer de graves dégâts.

Dommages corporels ou matériels causés par bâches

⇒ N'utilisez pas de bâche.



AVERTISSEMENT

Le porte-vélo se positionne correctement sur l'accouplement après la fixation et quelques kilomètres roulés. .

Dommages corporels ou matériels causés par la perte du porte-vélo.

- ⇒ Contrôlez la bonne fixation du porte-vélo après quelques kilomètres.
- ⇒ Montez le porte-vélo à nouveau s'il est desserré.



AVERTISSEMENT

Conduire sur un terrain peu praticable avec le porte-vélo monté peut provoquer une rupture du porte-vélo.

Dommages corporels ou matériels causés par une rupture du porte-vélo.

⇒ N'utilisez pas le porte-vélo sur un terrain peu praticable.



ATTENTION

Le hayon peut entrer en contact avec le porte-vélo et être endommagé.

Dommages matériels causés par l'ouverture du hayon.

- ⇒ Les hayons électriques doivent être éteints et actionnés manuellement.
- ⇒ Rabattez le porte-vélo avant d'ouvrir le hayon.



ATTENTION

Le porte-vélo ou les vélos peuvent subir des dégâts s'ils sont placés directement au niveau du pot d'échappement.

Dommages matériels causés par des gaz d'échappement chauds.

⇒ Utilisez un embout d'échappement si nécessaire.

Avant la première mise en service

Montage de la plaque d'immatriculation sur le porte- vélo

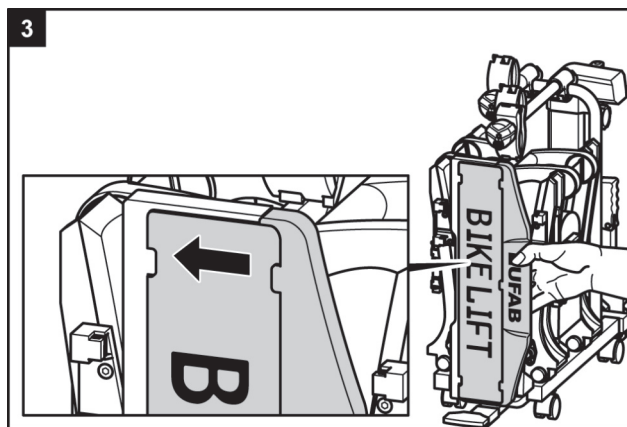
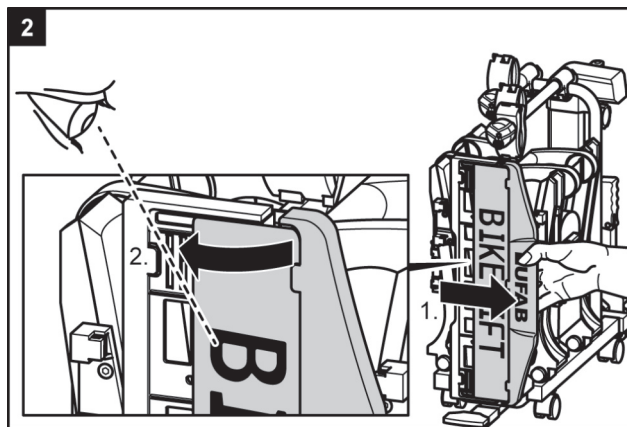
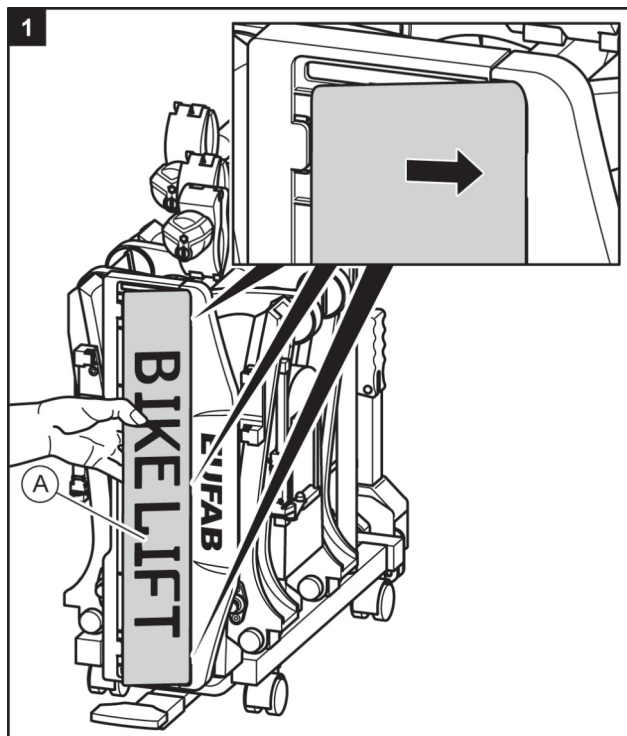

Montage et utilisation

Montage du porte-vélo sur l'accouplement de remorque

- ⇒ Garez votre véhicule sur une surface plane.
- ⇒ Tirez le frein à main.

Différentes possibilités de montage

Vous pouvez monter le porte-vélo sur l'accouplement de remorque de deux façons différentes.

1. Soulevez le porte-vélo à la main sur l'accouplement de remorque.
Avantage : montage rapide.
Désavantage : demande plus d'effort que le montage par moteur incorporé.
⇒ Suivez les étapes 1 – 6 et 17 – 23 dans ce chapitre.
2. Soulevez le porte-vélo au moyen du moteur incorporé sur l'accouplement de remorque.
Avantage : effort minimum nécessaire.
Désavantage : plus longs temps de montage que le montage manuel.
⇒ Suivez les étapes 1 – 2 et 7 – 23 dans ce chapitre.



AVERTISSEMENT

Des dommages sur le porte-vélo, par exemple à cause de pièces pliées ou des déchirures ne permettent pas le bon fonctionnement du porte-vélo

Dommages corporels ou matériels causés par un porte-vélo endommagé.

- ⇒ Ne montez pas le porte-vélo s'il est endommagé.
- ⇒ Procédez comme indiqué dans le chapitre Maintenance.



AVERTISSEMENT

Une connexion sale ou détériorée entre le porte-vélo et l'accouplement de remorque peut provoquer le desserrement du porte-vélo.

Dommages corporels ou matériels causés par la perte du porte-vélo pendant le trajet.

- ⇒ Remplacez un accouplement de remorque détérioré.
- ⇒ Nettoyer la boue, poussière et la graisse sur l'accouplement de remorque.



REMARQUE

Il y a souvent une couche de vernie sur la boule d'accouplement.

Pour la meilleure prise possible du porte-vélo, la couche de vernies doit être retirée avec précaution. Respectez les consignes de sécurité du fabricant d'accouplement.

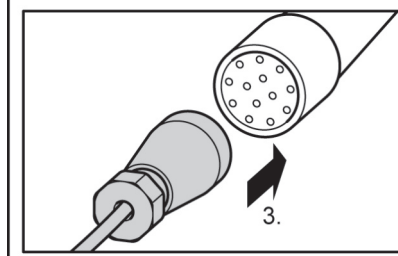
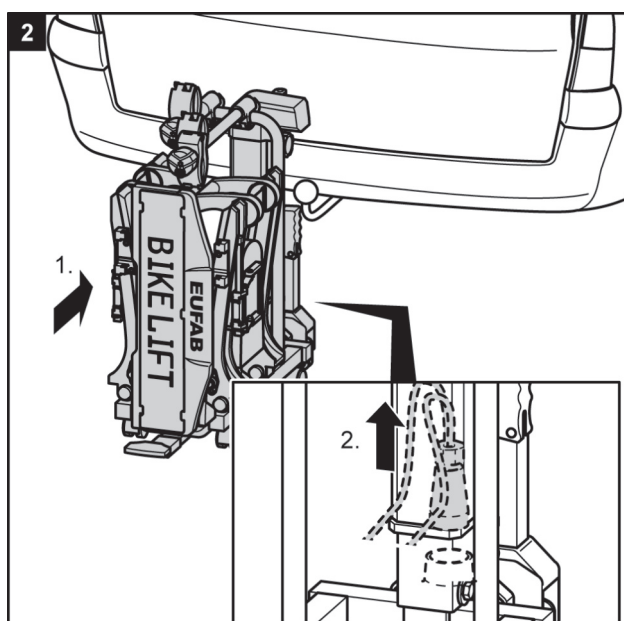
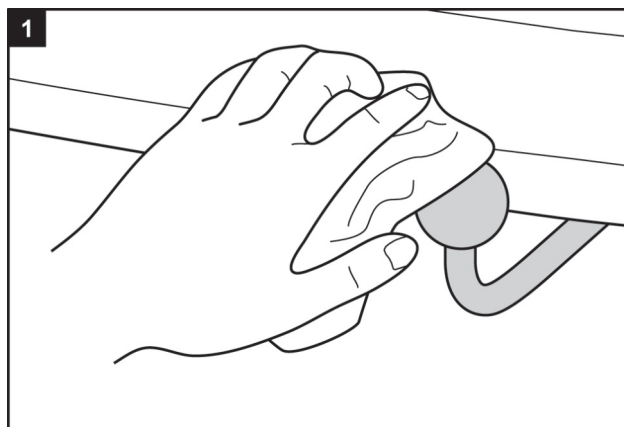

- ⇒ **3** Soulever à la main, suivez les étapes suivantes

- ⇒ **7** Soulever avec le moteur incorporé, continuez à partir de l'étape 7.

Soulever le porte-vélo à la main et le placer sur l'accouplement de remorque.

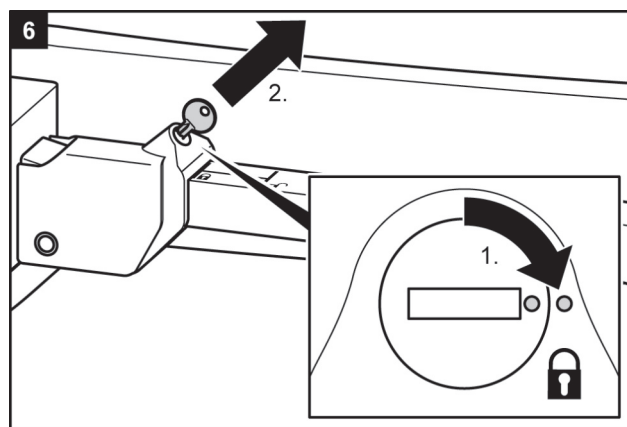
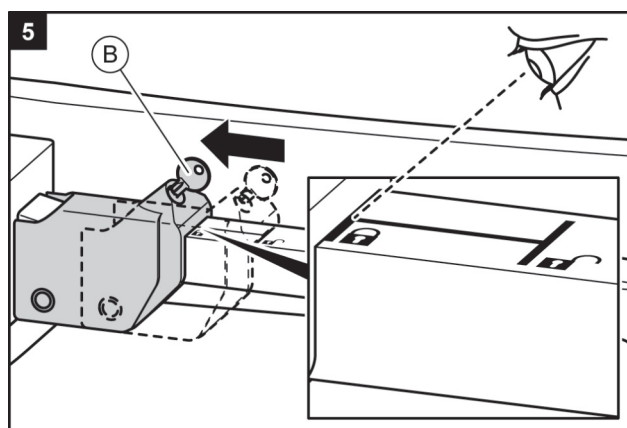
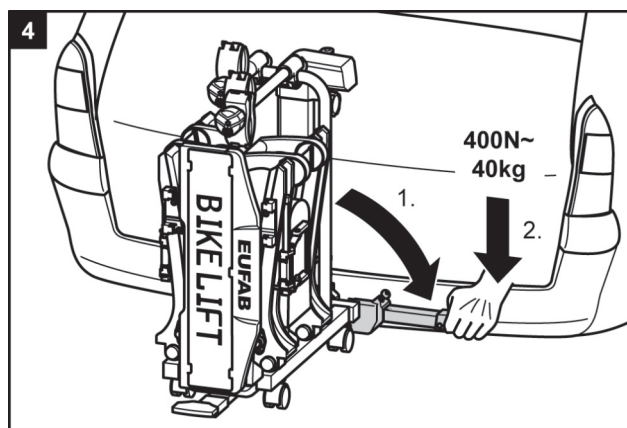
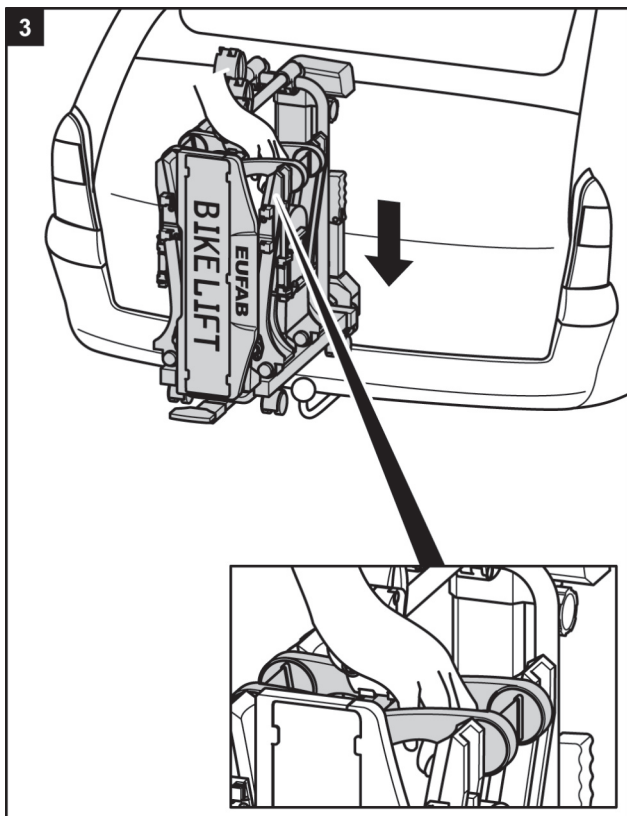

AVERTISSEMENT

Si le levier n'est pas sécurisé à clé, le porte-vélo peut se desserrer pendant le trajet.

Domages corporels ou matériels causés par un porte-vélo mal assuré.

- ⇒ Fermez le porte-vélo avec une clé.
- ⇒ Vérifiez si vous avez tiré le levier et retirer la clé.

En fermant avec une clé, vous empêchez le vol éventuel du porte-vélo.



AVERTISSEMENT

Une mauvaise connexion entre le porte-vélo et l'accouplement de remorque peut provoquer le desserrement du porte-vélo

Domages corporels ou matériels causés par la perte du porte-vélo pendant le trajet.

- ⇒ Vérifiez que le porte-vélo soit bien
- ⇒ En cas de connexion mal serrée, répétez l'étape 3 – 6. S'il n'y a pas d'amélioration, le système de démontage rapide doit éventuellement être réglé, voir chapitre Maintenance.

⇒ **17** Suivez à partir d'ici l'étape 17 dans ce chapitre.

Soulevez le porte-vélo avec le moteur incorporé sur l'accouplement de remorque

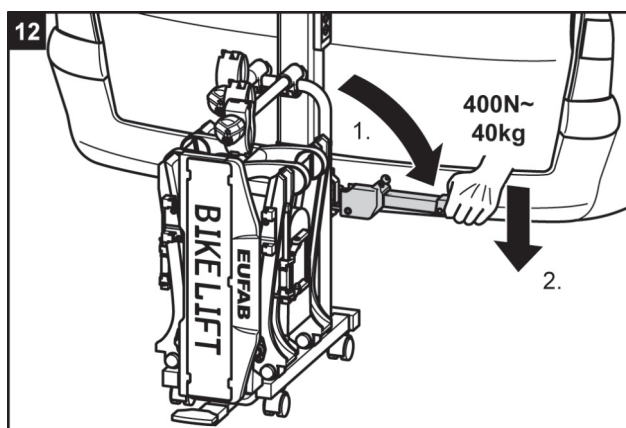
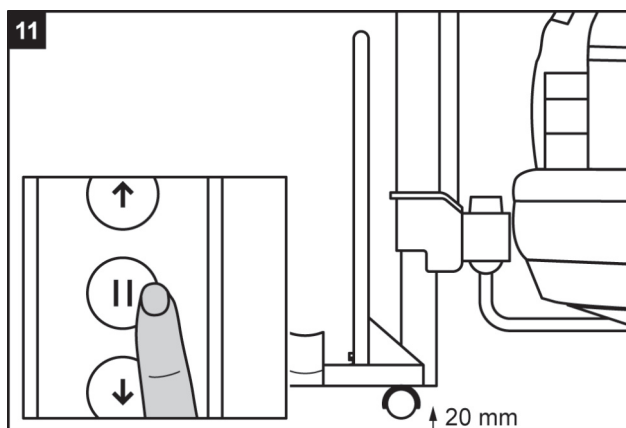
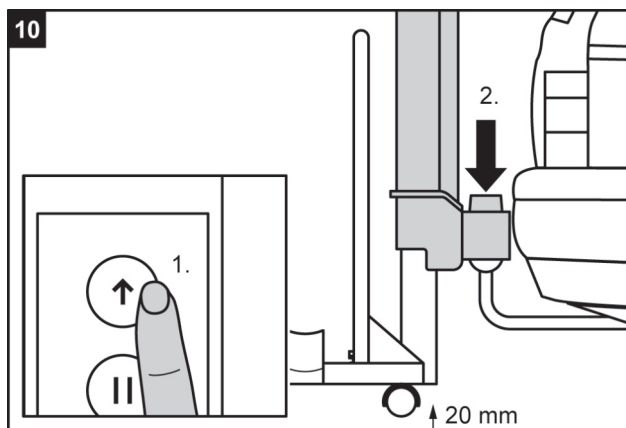
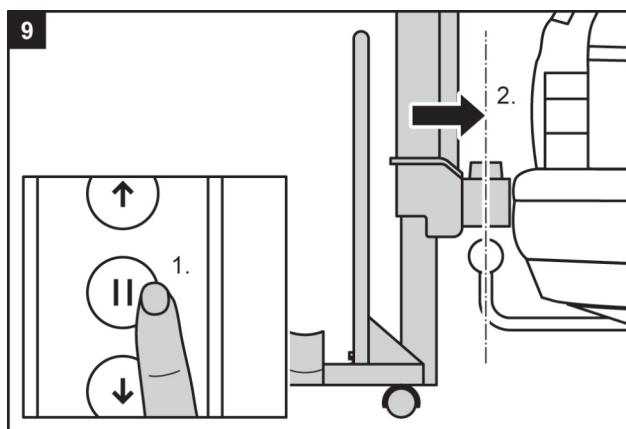
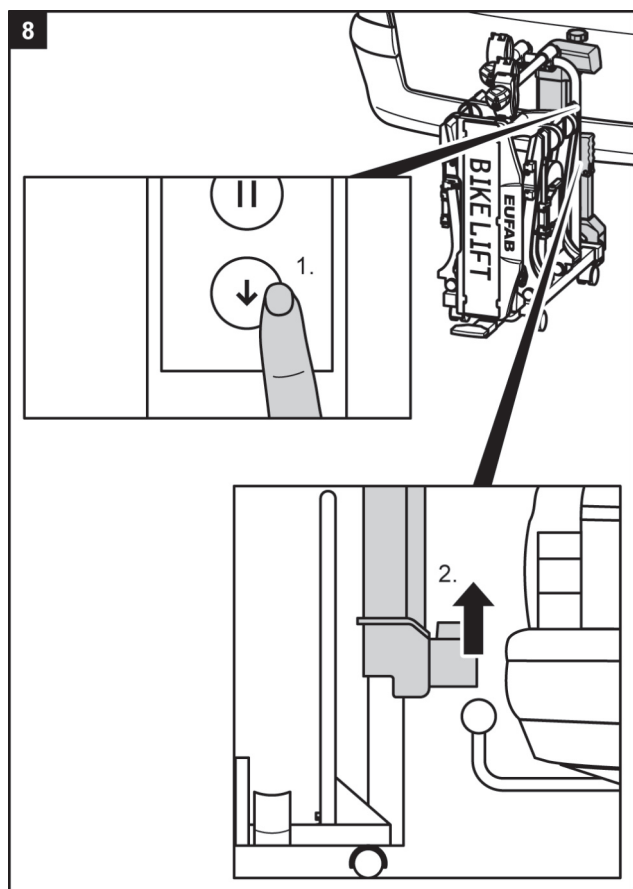
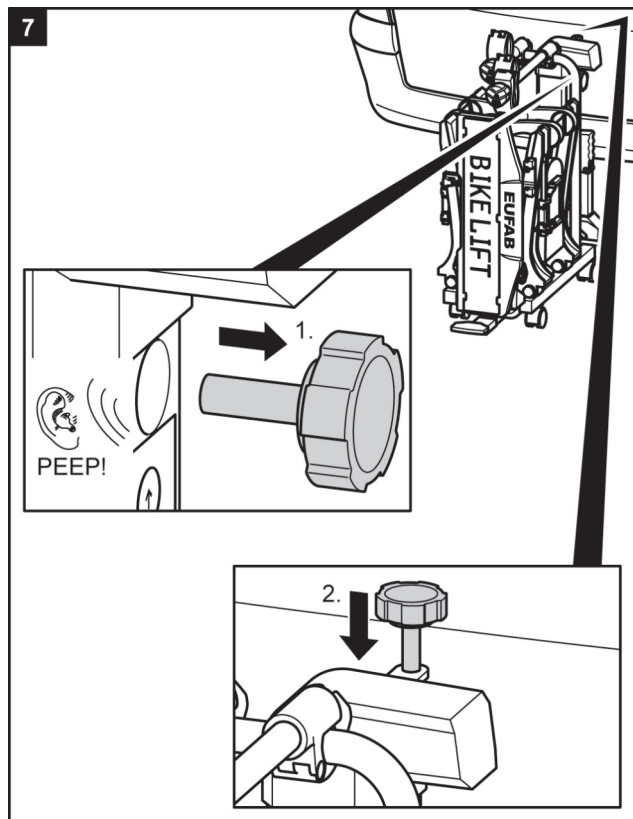

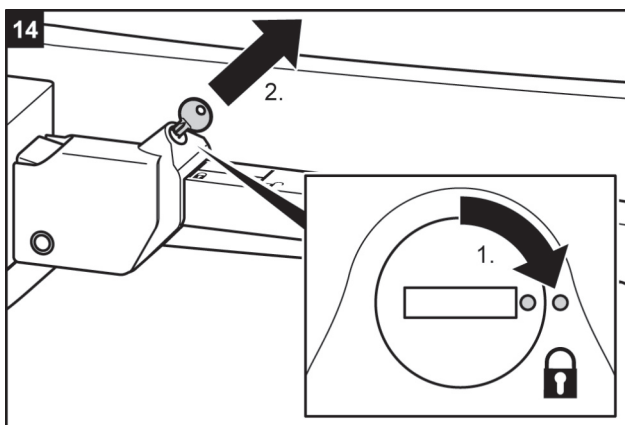
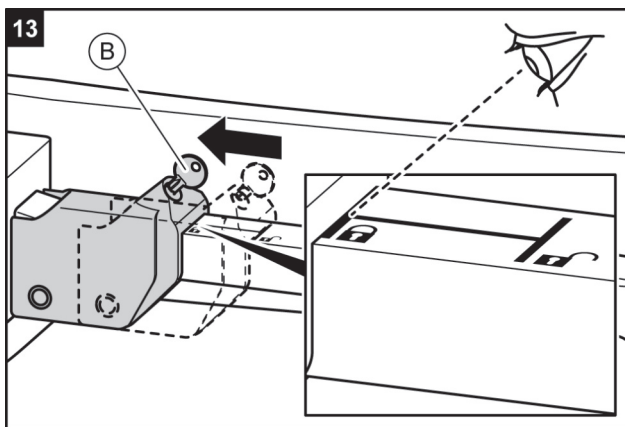

AVERTISSEMENT

Si le levier n'est pas sécurisé à clé, le porte-vélo peut se desserrer du véhicule pendant le trajet.

Domages corporels ou matériels causés par un porte-vélo mal assuré.

- ⇒ Fermez le porte-vélo avec une clé.
- ⇒ Vérifiez si vous avez tiré le frein à main et retirez la clé.

En fermant à clé, vous empêchez le vol éventuel du porte-vélo.



AVERTISSEMENT

Une mauvaise connexion entre le porte-vélo et le véhicule peut provoquer le desserrement du porte-vélo.

Domages corporels ou matériels causés par la perte du porte-vélo pendant le trajet.

- ⇒ Vérifiez que le porte-vélo soit bien fixé.
- ⇒ En cas de mauvaise connexion, répétez l'étape 1 à 14. S'il n'y a pas d'amélioration, le système de démontage rapide doit éventuellement être réglé, voir chapitre Maintenance.

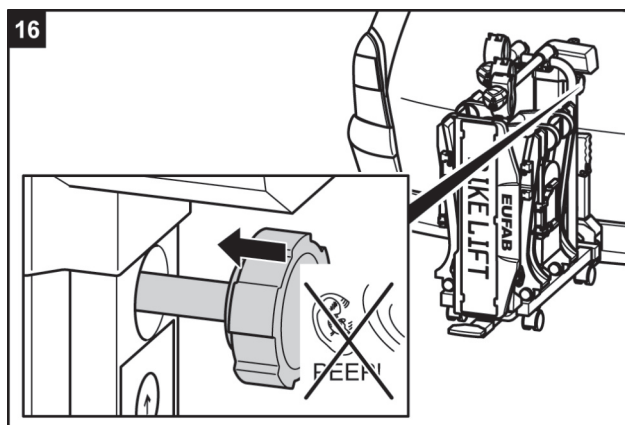
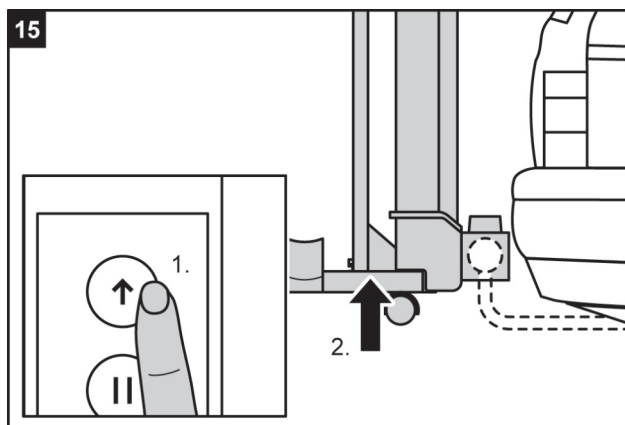

- ⇒ A partir de l'étape suivante, la suite de montage est la même pour la soulevé automatique ou manuel.

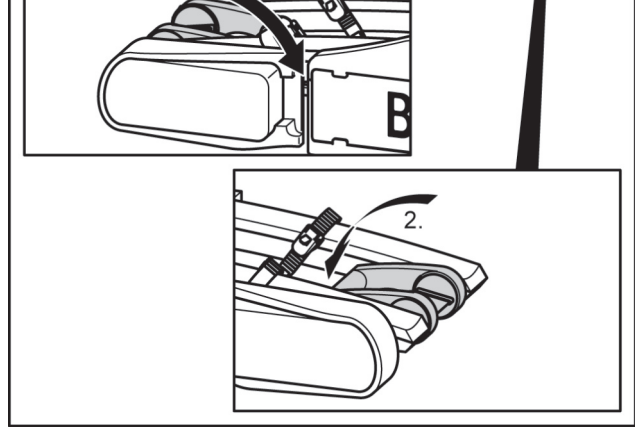
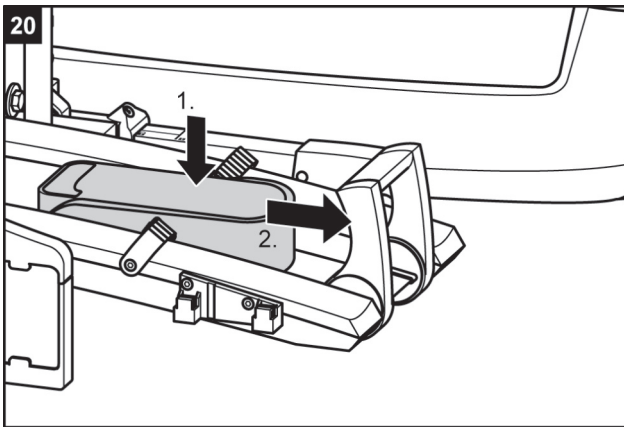
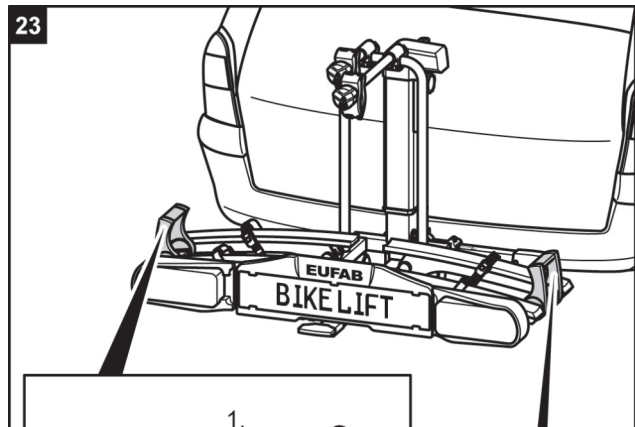
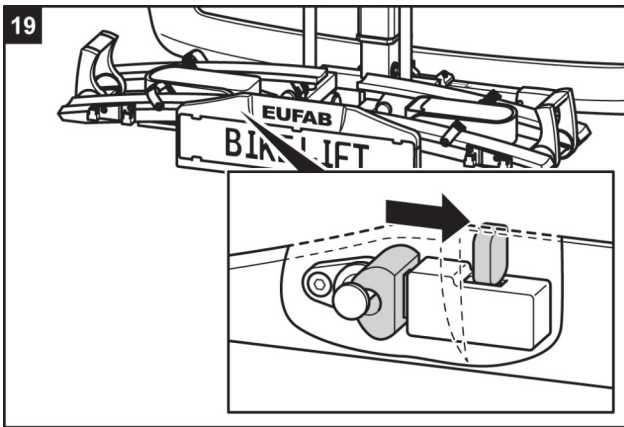
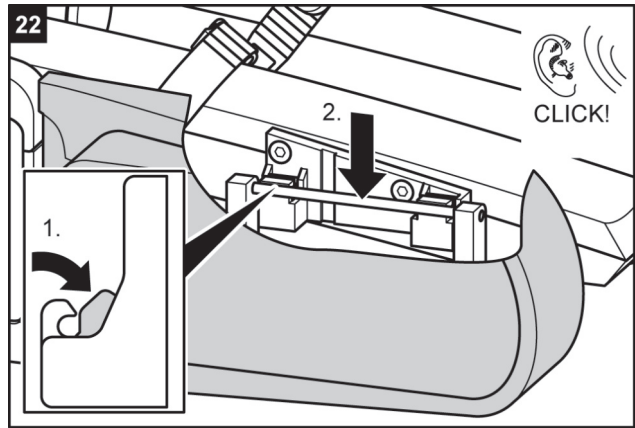
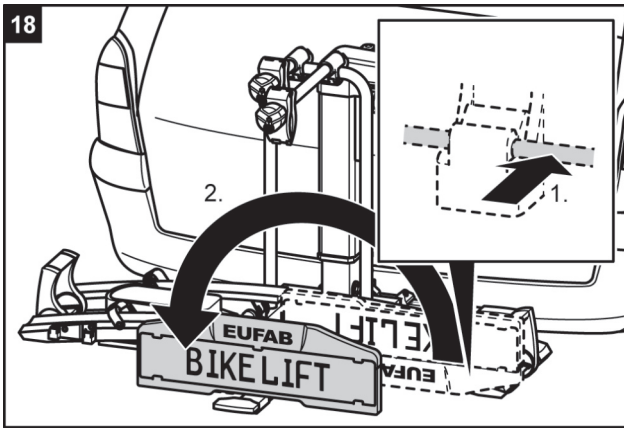
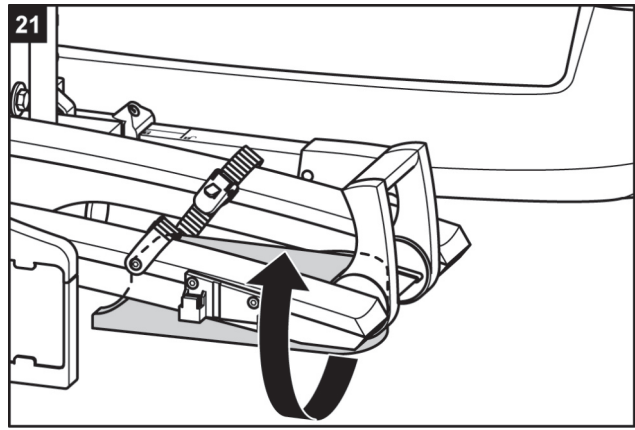
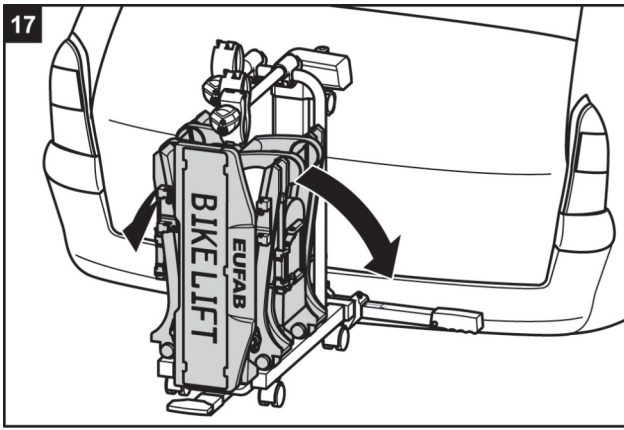



AVERTISSEMENT

Conduire sans système d'éclairage en état de marche peut provoquer des accidents.

Dommages corporels causés par un autre usager de la route non aperçu.

- ⇒ Vérifiez avant chaque départ le bon fonctionnement du système d'éclairage.
- ⇒ Remplacez une ampoule défectueuse si nécessaire.
- ⇒ Vérifiez la connexion entre la fiche et l'accouplement.

Abaisser et redresser le porte-vélo

Abaisser le porte-vélo



AVERTISSEMENT

Un porte-vélo qui n'est pas redressé ou assuré peut se prendre dans des obstacles.

Dommages corporels ou matériels causés par la perte de porte-vélo pendant le trajet.

- ⇒ Soulevez le porte-vélo avant chaque départ jusqu'en position finale.
- ⇒ Sécurisez à tout prix la goupille de sécurité comme décrit en dessous de « Soulever le porte-vélo ».



PRUDENCE

Les parties corporelles ou objets se trouvant sous le porte-vélo peuvent être écrasés.

Dommages corporels ou matériels causés par l'abaissement du porte-vélo.

- ⇒ Assurez-vous que rien ne se trouve sous le porte-vélo.
- ⇒ Faites attention à votre corps, maintenez une distance de sécurité.

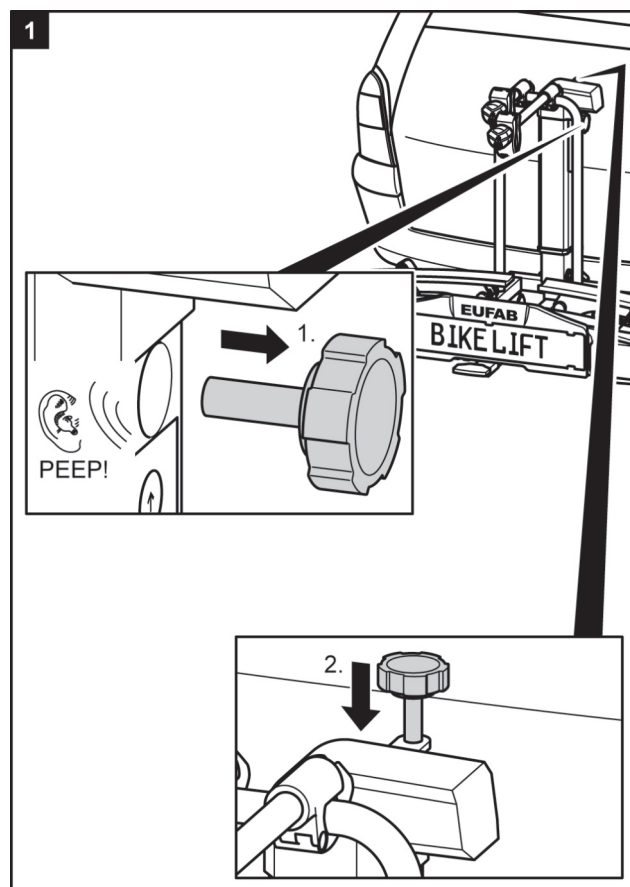

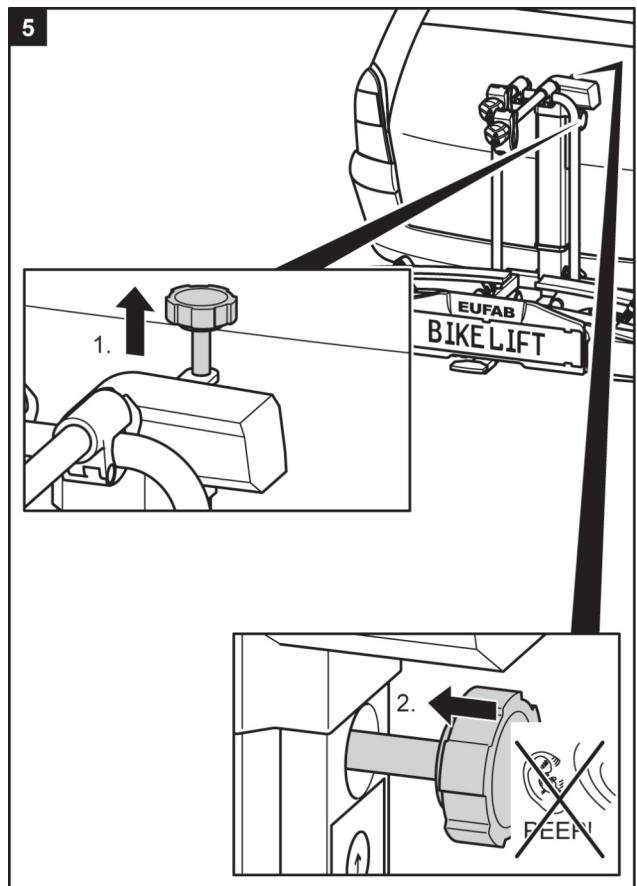
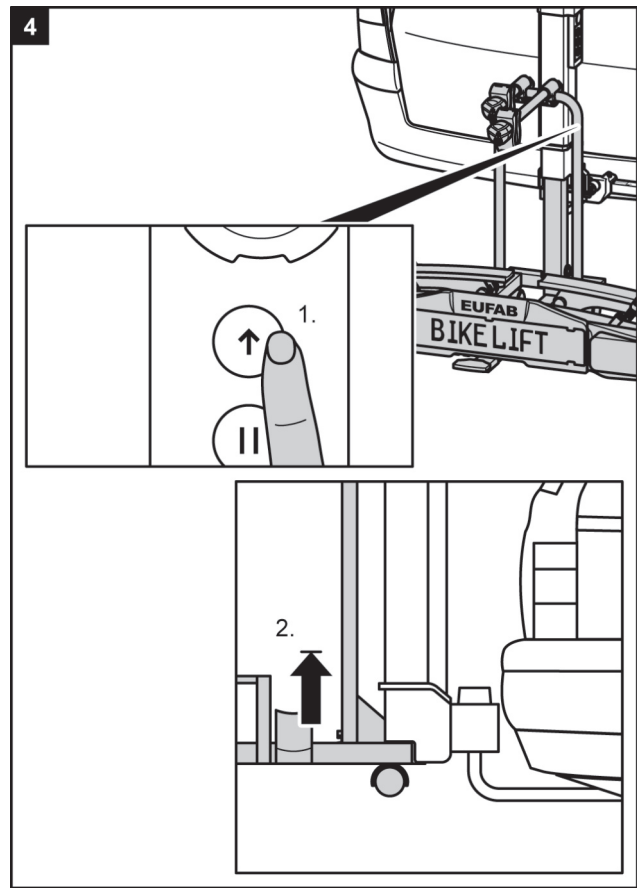
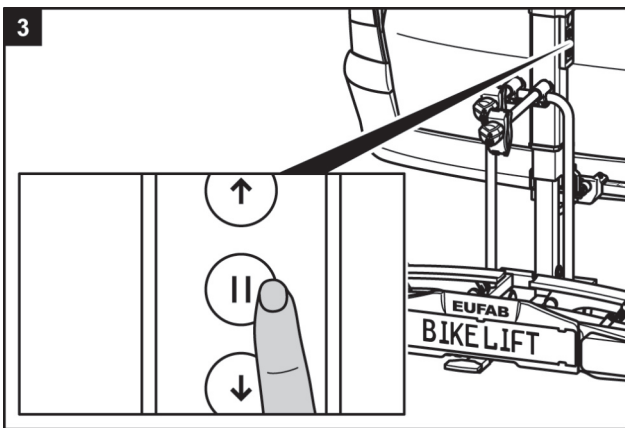
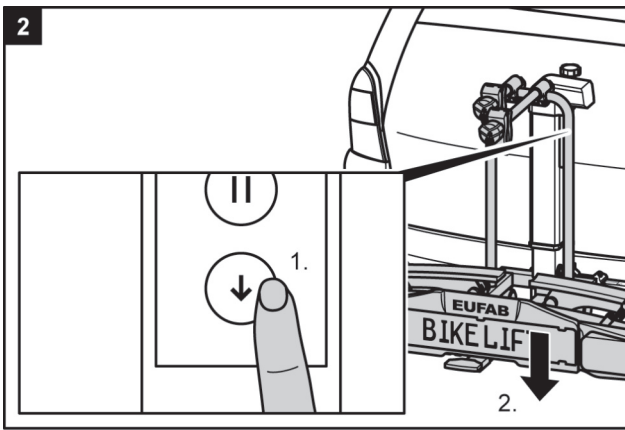

Soulever et sécuriser le porte-vélo

- ⇒ Soulevez le porte-vélo à fond.
- ⇒ Montez la goupille de sécurité. La goupille ne peut être montée que lorsque le porte-vélo se trouve en position élevée.
- ⇒ Un bruit d'avertissement retentit après le montage de la goupille de sécurité.



AVERTISSEMENT

Abaisser le porte-vélo pendant le trajet peut provoquer des accidents.

Domages corporels ou matériels causés par l'abaissement du porte-vélo pendant le trajet.

- ⇒ Assurez-vous que la goupille de sécurité soit complètement enfoncée après avoir été soulevée.
- ⇒ Si la goupille n'est pas complètement enfoncée, un bruit d'avertissement retentit.
- ⇒ Si c'est le cas, desserrez la goupille de sécurité à fond et renfoncez la complètement.

Fixation des vélos

⇒ Abaisser ensuite la surface d'appui du porte-vélo comme indiqué dans le chapitre « Abaisser le porte-vélo ».



REMARQUE

Dans certains cas, il n'est pas possible de sortir suffisamment le porte-vélos pour le placer sur la boule d'attelage comme décrit à l'étape 9.

Dans ce cas, basculez légèrement le porte-vélos afin d'atteindre la hauteur nécessaire sur l'attelage.



AVERTISSEMENT

Des parties mal vissées au vélo peuvent se desserrer pendant le trajet.

Dommages corporels ou matériels causés par des pièces volantes.

- ⇒ Retirez toute pièce qui n'est pas convenablement fixée au vélo, par exemple les pompes à air, les sacoches pour vélo, appareils de navigation, piles ou batterie.
- ⇒ Retirez également toute pièce qui crée une résistance de l'air, par exemple porte-bagage et siège enfant.



REMARQUE

Afin d'améliorer le comportement de votre véhicule, montez d'abord le vélo le plus lourd. De plus, si vous ne montez qu'un vélo, vous devriez placer le vélo dans la barre qui se trouve le plus près du coin du véhicule.

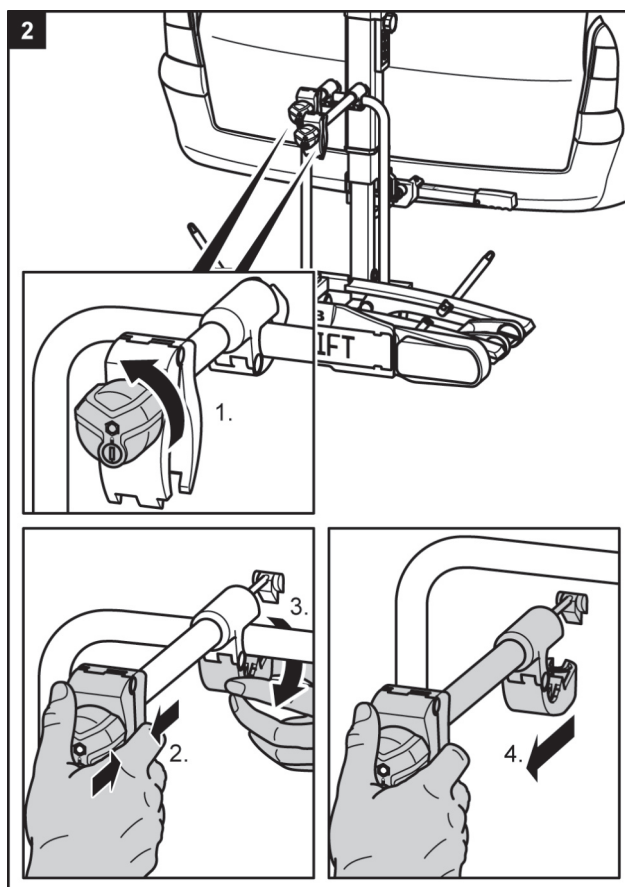
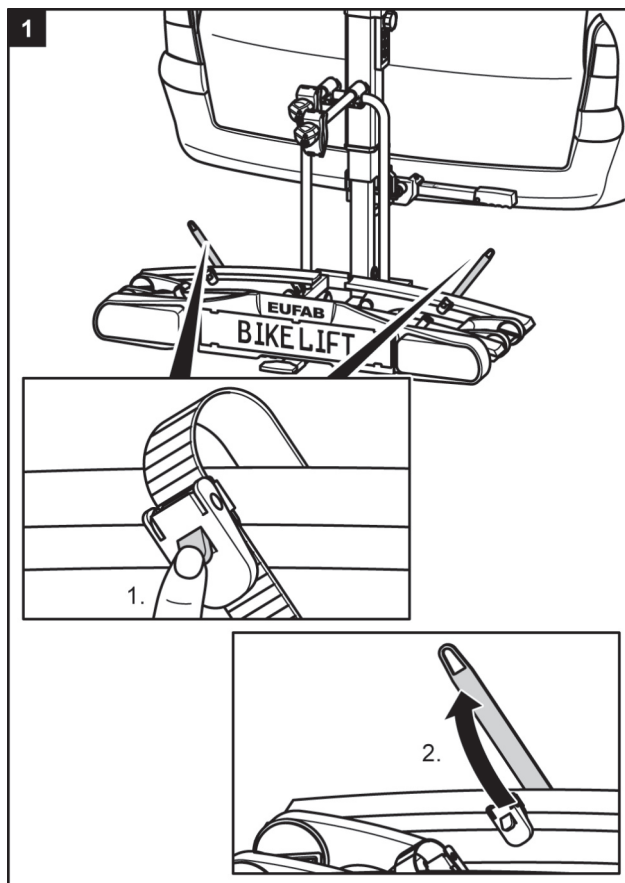

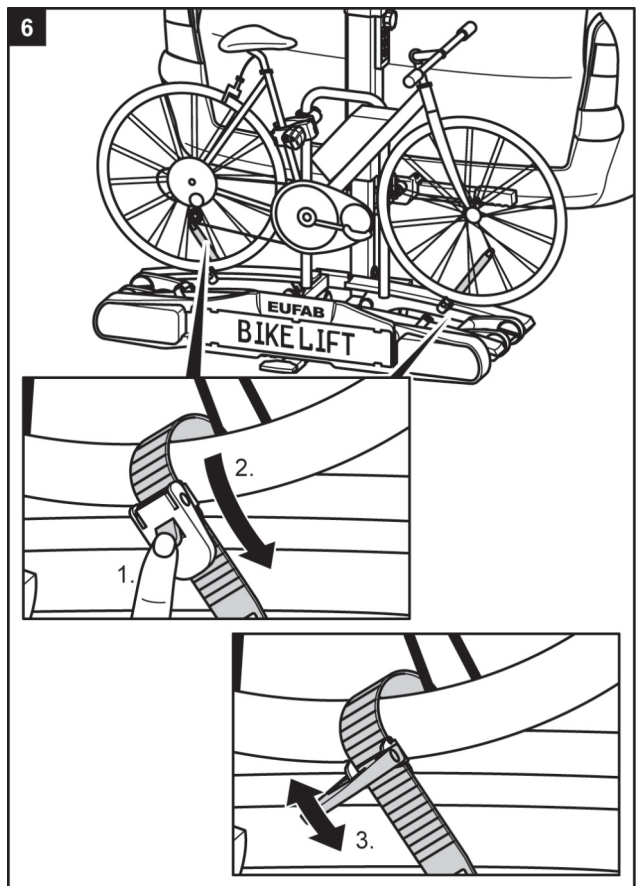
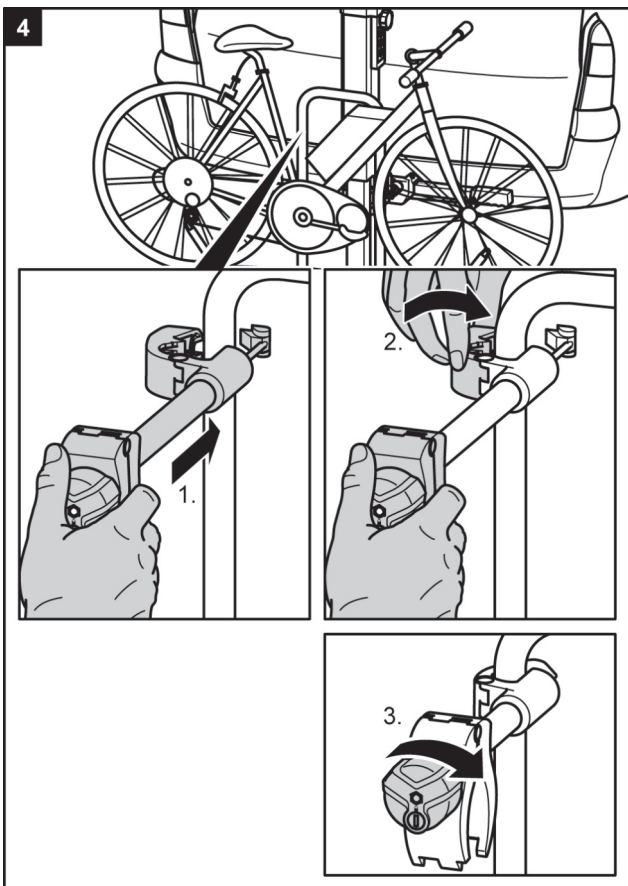
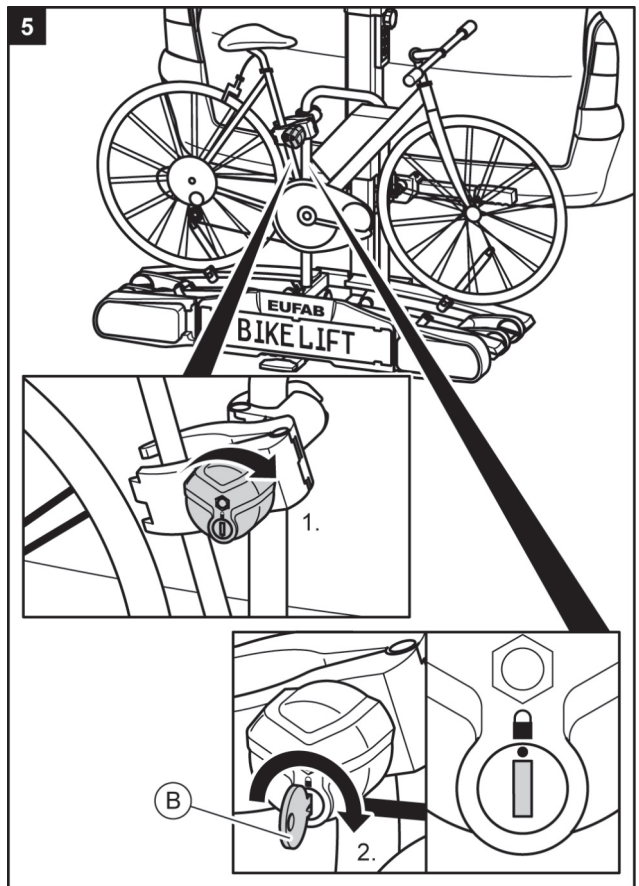
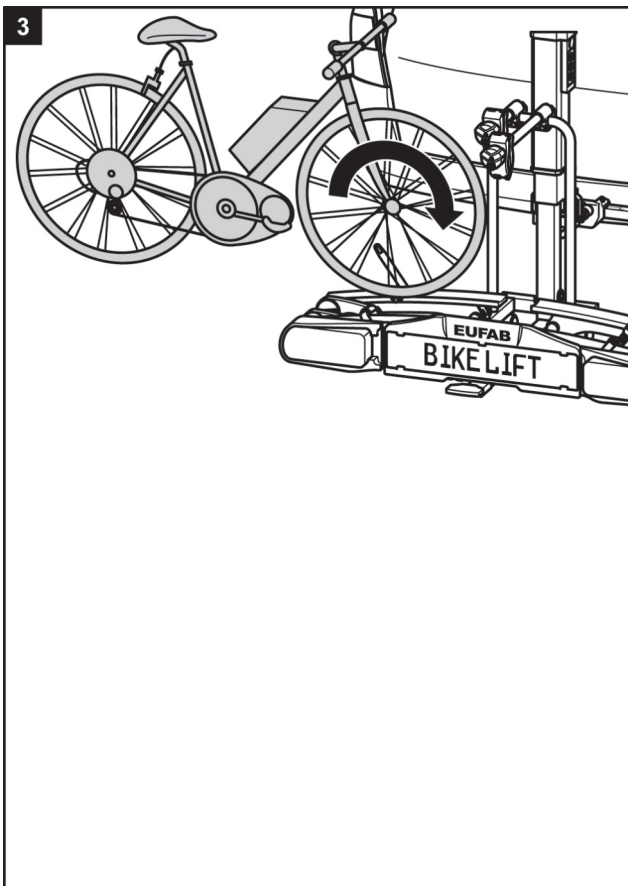

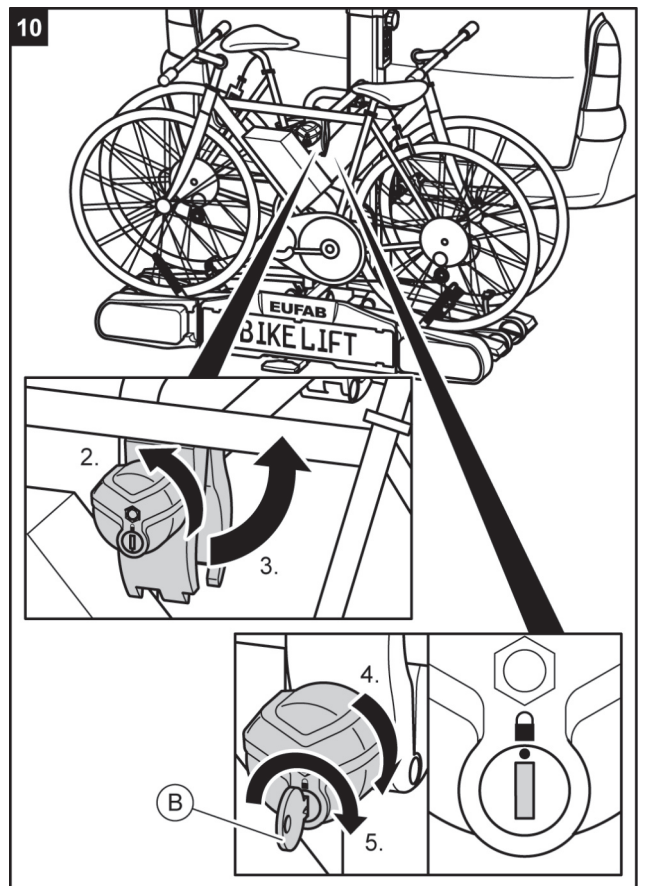
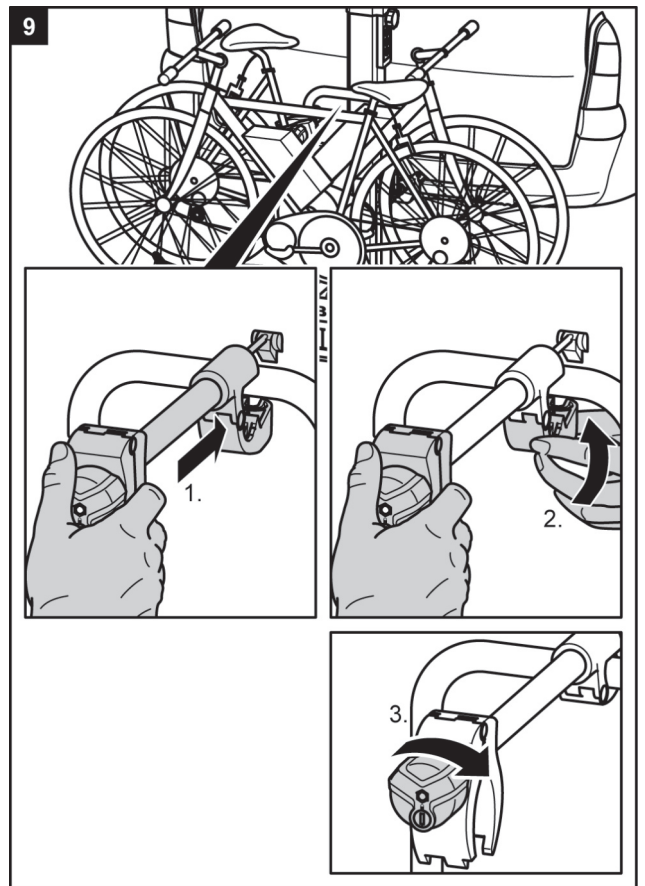
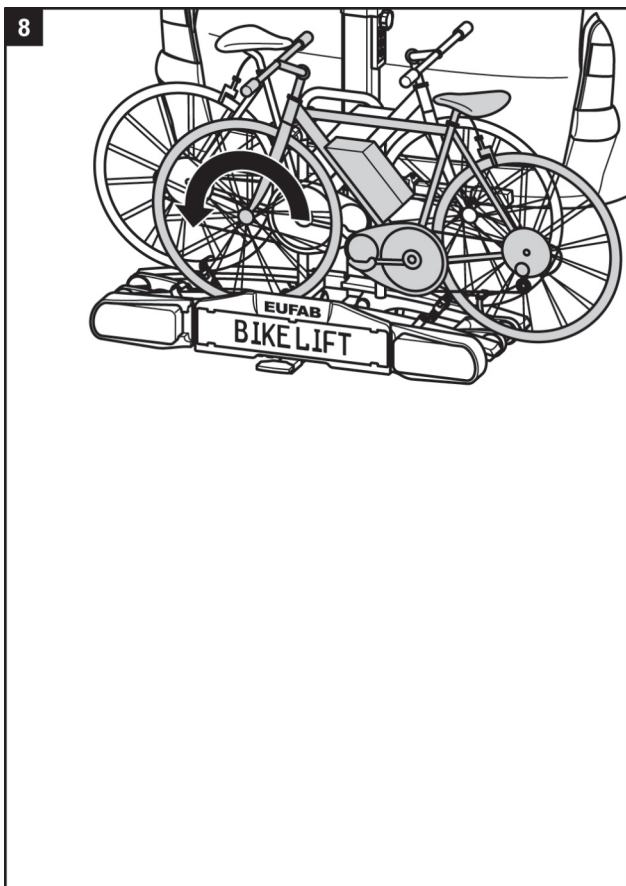
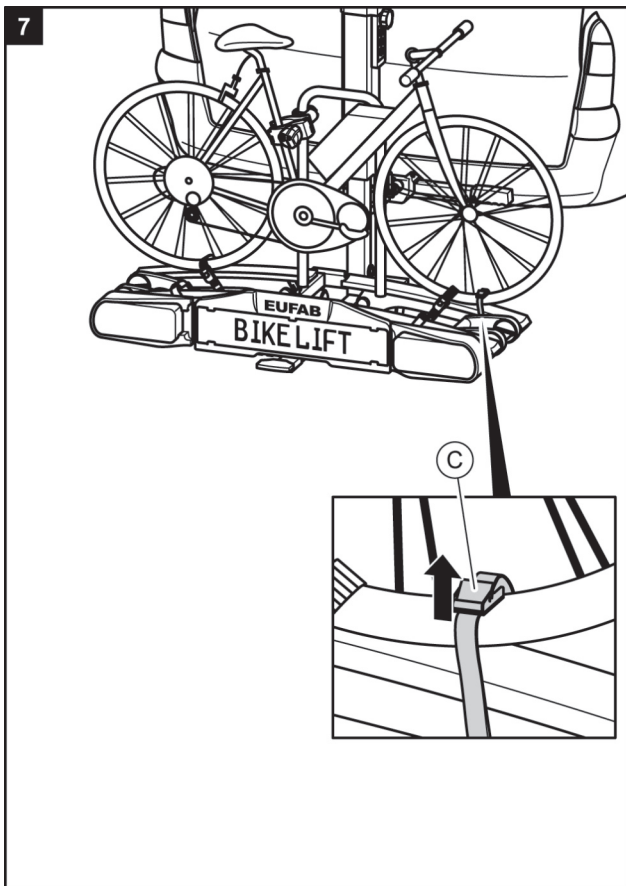

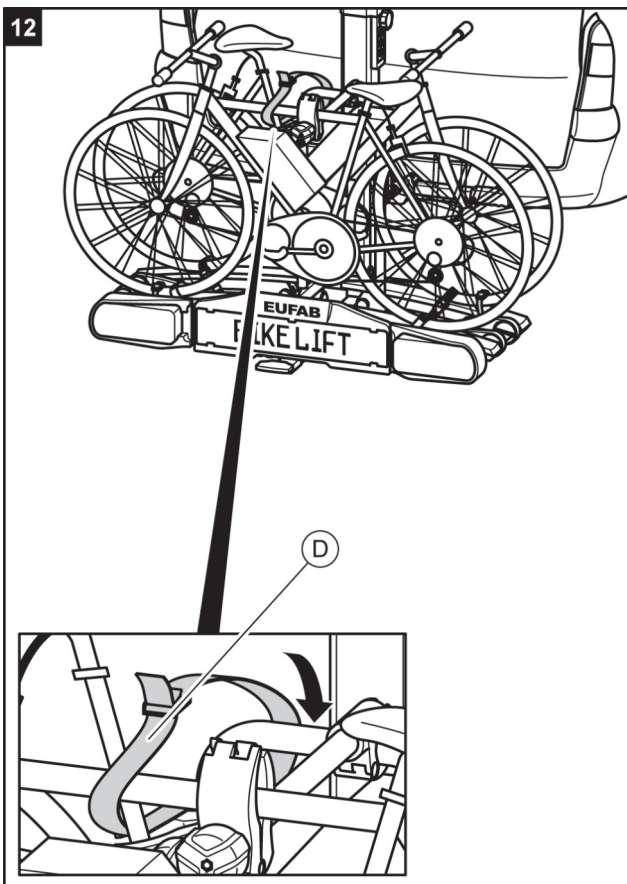
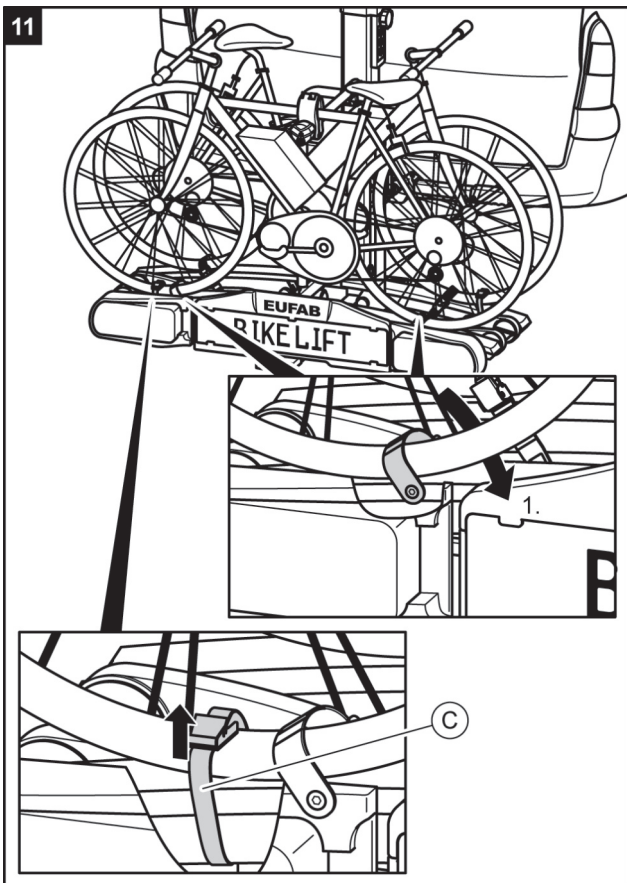
**AVERTISSEMENT**

Conduire sans sangles de sécurité peut provoquer des accidents.

Dommages corporels ou matériels causés par la perte du porte-vélo.

- ⇒ Contrôlez avant chaque départ le bon placement des sangles autour des vélos et de l'étrier en U du porte-vélo, voir étape 12 dans ce chapitre.
- ⇒ Contrôlez avant chaque départ le bon placement des deux sangles sur la roue avant et la roue arrière du vélo.
- ⇒ Resserrez les sangles si besoin.
- ⇒ Contrôlez avant chaque départ que les sangles utilisées ne soient pas endommagées ou usées.
- ⇒ Des sangles endommagées ou usées doivent être remplacées par des sangles intactes. Seules les sangles agréées par EAL GmbH peuvent être utilisées.

**AVERTISSEMENT**

Une mauvaise connexion entre le porte-vélo et le vélo peut desserrer le lien et provoquer la perte d'un vélo.

Dommages corporels ou matériels causés par la perte d'un vélo pendant le trajet.

- ⇒ Vérifiez que les vélos soient correctement et complètement fixés.
- ⇒ En cas de mauvaise connexion, répétez les étapes 1 à 12 de ce chapitre.

- ⇒ Soulevez maintenant le porte-vélo comme indiqué dans le chapitre « Soulever le porte-vélo »

**AVERTISSEMENT**

Un porte-vélo qui n'est pas redressé ni assuré peut se prendre dans des obstacles.

Dommages corporels ou matériels causés par la perte du porte-vélo pendant le trajet.

- ⇒ Soulevez le porte-vélo avant chaque départ jusqu'à la position finale.
- ⇒ Sécurisez à tout prix le porte-vélo avec la goupille de sécurité comme indiqué dans le chapitre « Soulever le porte-vélo ».

Basculer le porte-vélo, accès au coffre

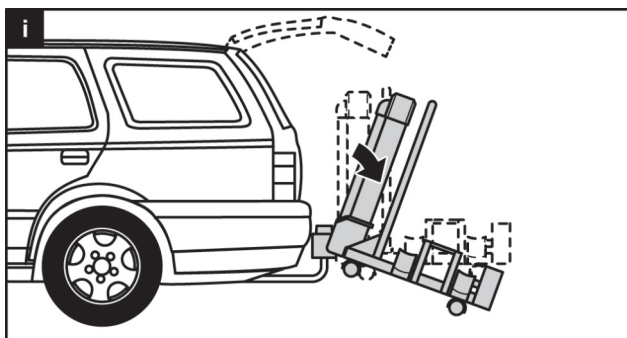

PRUDENCE

Le hayon peut entrer en contact avec le porte-vélo et être endommagé. .

Dommages matériels causés par l'ouverture du hayon.

- ⇒ Les hayons électriques doivent être éteints et actionnés manuellement.
- ⇒ Rabattez le porte-vélo avant d'ouvrir le hayon.



PRUDENCE

Dommages corporels ou matériels en cas de rabattement soudain vers le bas.

Les parties corporelles ou les objets se trouvant sous ou devant le porte-vélo peuvent être écrasés.

- ⇒ Assurez-vous que rien ne se trouve sous le porte-vélo.
- ⇒ Faites attention à votre corps, en particuliers à votre tête, gardez une distance de sécurité.
- ⇒ Desserrez le verrouillage (1.) Agrippez le porte-vélo lorsque vous le rabattez vers le bas (2.). Desserrez le verrouillage avec le pied (3.) et basculez ensuite le porte-vélo vers le bas avec la main.

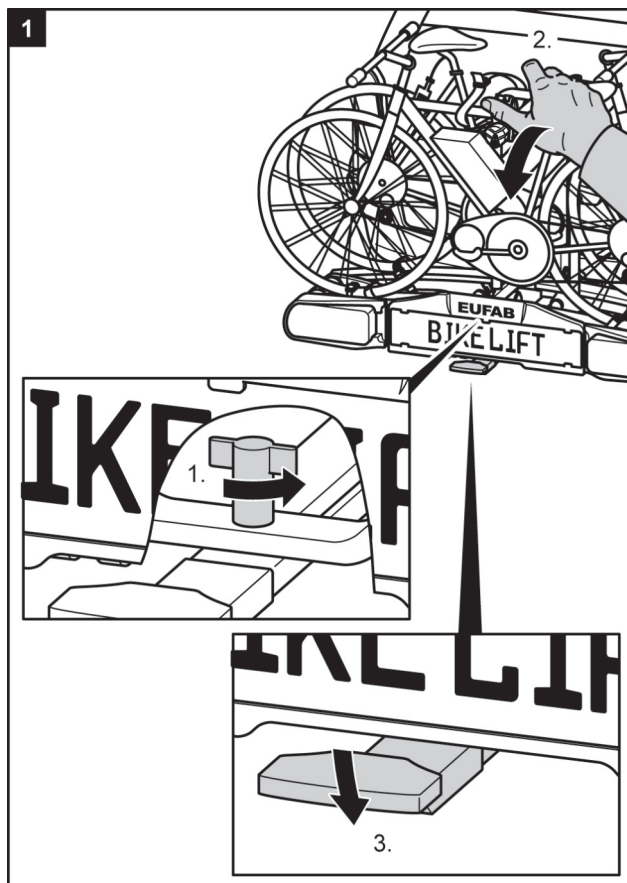

PRUDENCE

Dommages corporels ou matériels causés par rabattement vers le haut.

Les parties corporelles ou les objets se trouvant entre le support et le véhicule peuvent être écrasés.

- ⇒ Assurez-vous que rien ne se trouve entre le porte-vélo et le véhicule.
- ⇒ Retirez tout entre le porte-vélo et le véhicule.

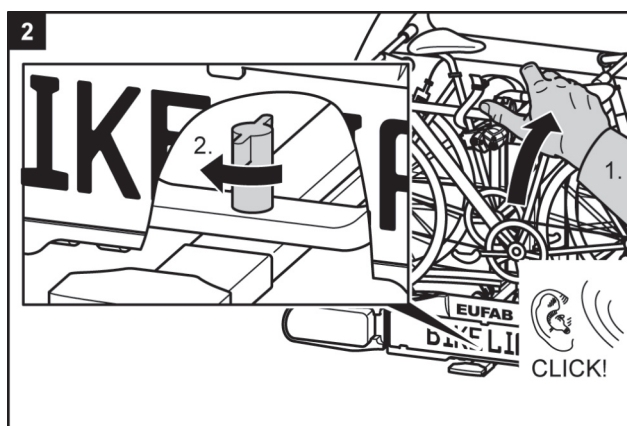

**AVERTISSEMENT**

Un porte-vélo non rabattu peut arracher le support ou l'accouplement.

Domages corporels ou matériels causés par la perte du porte-vélo possible.

- ⇒ Rabattez le porte-vélo vers le haut avant le départ.
- ⇒ Vérifiez si le porte-vélo est enclenché correctement. Si nécessaire, enclenchez le porte-vélo comme indiqué précédemment..

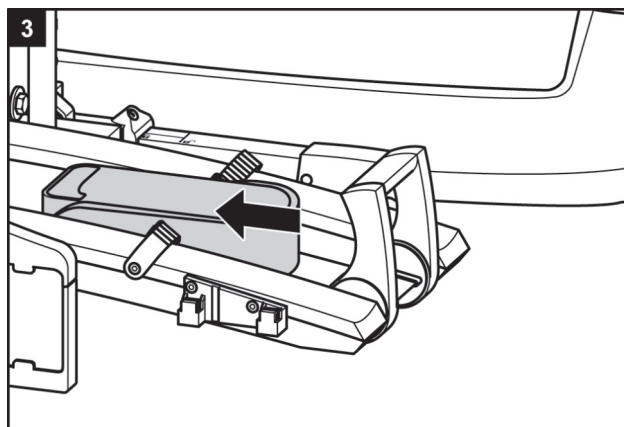
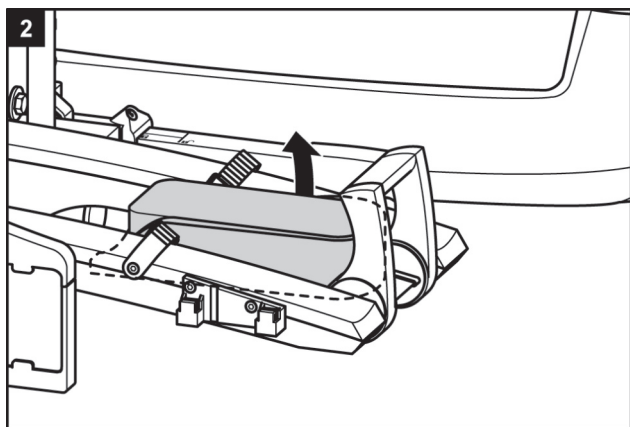
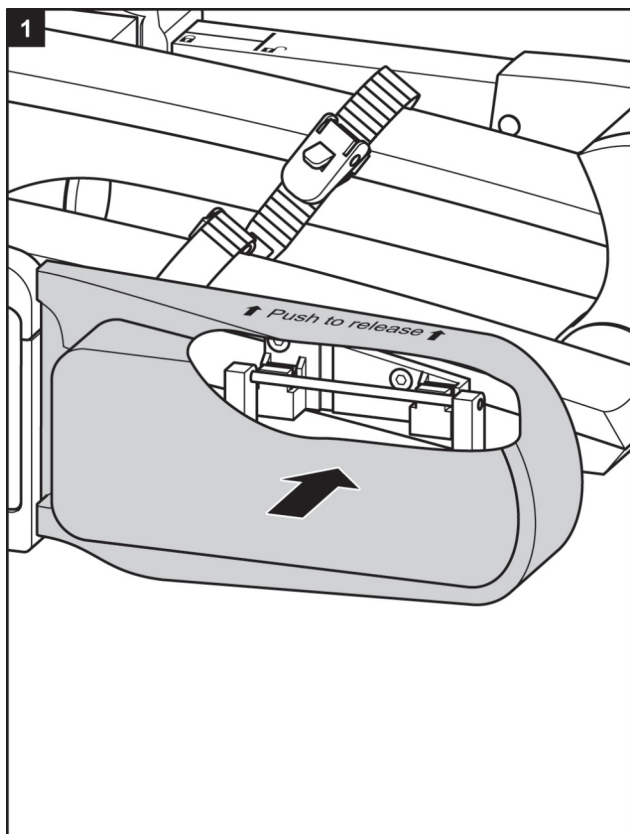
Démontage du porte-vélo

- ⇒ Pour retirer le porte-vélo, procédez ensuite dans l'ordre inverse du montage.

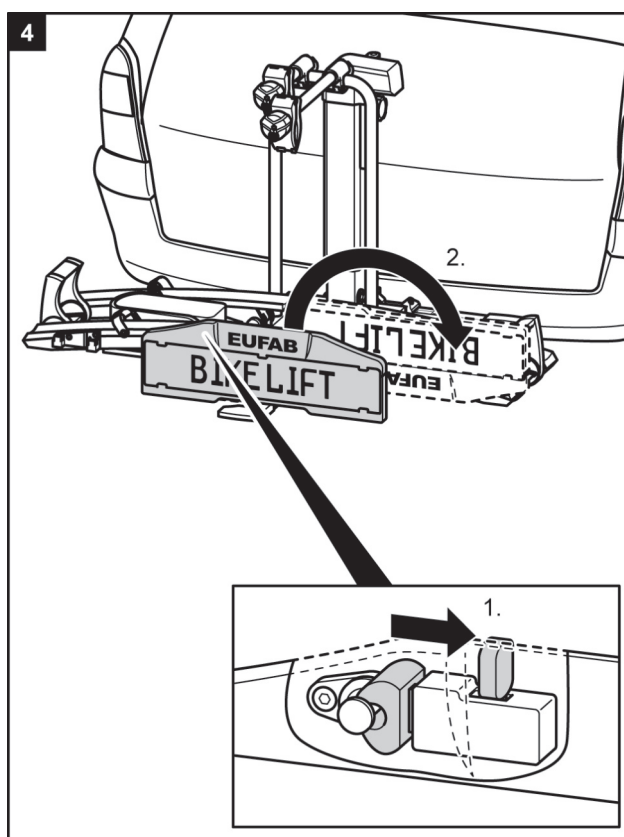

- ⇒ Pour retirer le porte-vélo, procédez ensuite dans l'ordre inverse du montage.

Porter le porte-vélo

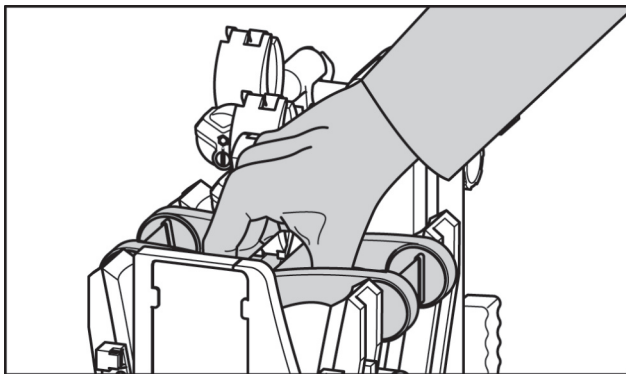

Rouler le porte-vélo

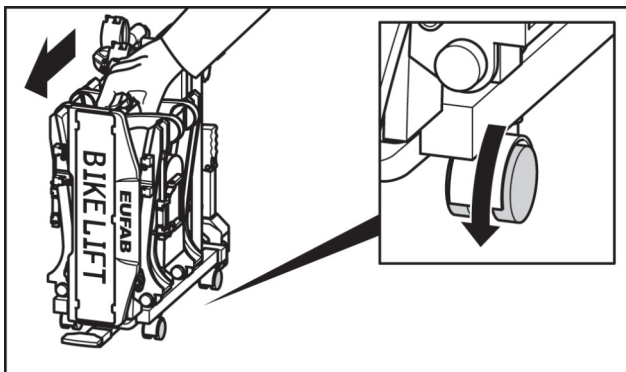

Ranger le porte-vélo dans la housse de protection

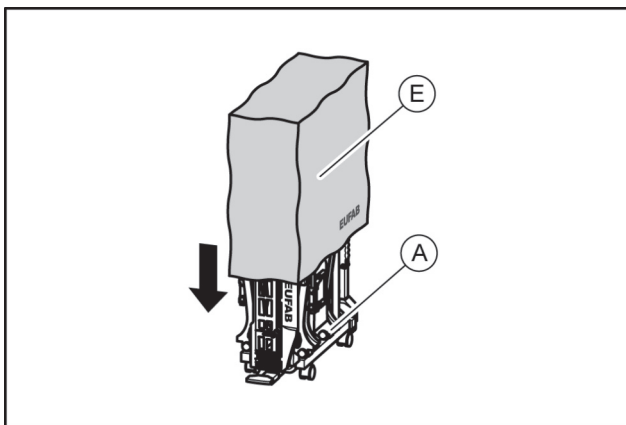

Nettoyage et entretien

Le porte-vélo peut être nettoyé avec un détergent doux, avec de l'eau chaude et/ou un chiffon doux. Retirez d'abord le gros des salissures. N'utilisez aucun solvant ou nettoyant similaire car ceux-ci peuvent endommager le porte-vélo.

Laissez d'abord le porte-vélo sécher. N'utilisez pas de sèche-cheveux ou autres appareils de chauffage pour accélérer le processus de séchage. En région côtière et par emploi en conditions d'hiver, nettoyez le porte-vélo régulièrement pour retirer le sel et augmenter sa durabilité.

En cas de non utilisation prolongée (par exemple en hiver), entreposez le porte-vélo au sec et à l'abri pour augmenter sa durabilité.

Maintenance

Avant chaque départ, vérifiez l'usure de votre porte-vélo. Les pièces en métal défectueuses doivent absolument être remplacées. Pour remplacer une pièce, adressez-vous à notre service après-vente. Toute modification de pièce et du matériel original ou sur la construction du porte-vélo peut nuire à la sécurité et aux performances.

Les pièces en acier du porte-vélo sont protégées en usine contre la corrosion par une peinture en poudre. Si cette couche de laque est endommagée, éliminez les dégâts de façon professionnelle le plus rapidement possible.

En cas d'usage normal du porte-vélo, celui-ci ne doit être que nettoyer et ne nécessite aucun autre entretien. Ne procédez à cette maintenance que si le porte-vélo ne peut être monté comme indiqué dans le chapitre Montage.

- ⇒ Décrochez le porte-vélo de l'accouplement de remorque comme indiqué dans Démontage.
- ⇒ Retirez le capuchon anti-poussière.
- ⇒ Desserrez un peu le contre-écrou, comme indiqué sur l'illustration.
- ⇒ Tournez la vis de réglage d'un quart.
- ⇒ Fixez le contre-écrou.
- ⇒ Vérifiez que le porte-vélo est maintenant fixé sur l'accouplement de remorque comme indiqué dans le montage. Si ce n'est pas le cas, répétez les étapes décrites plus haut.

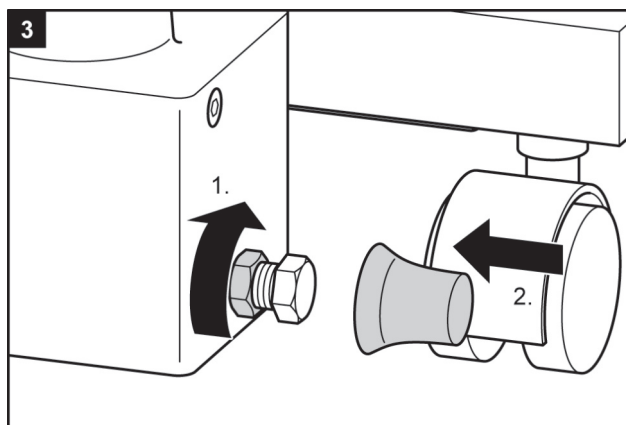
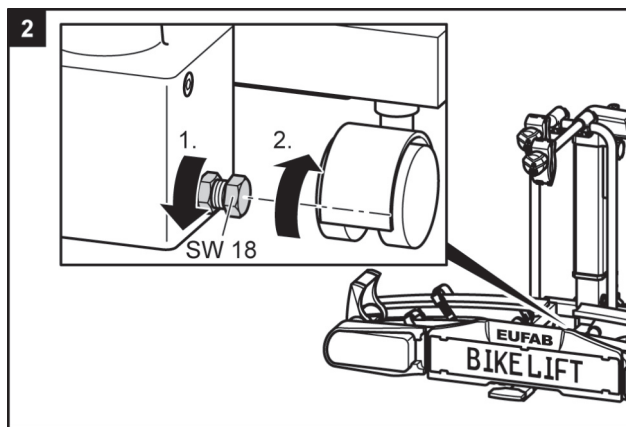
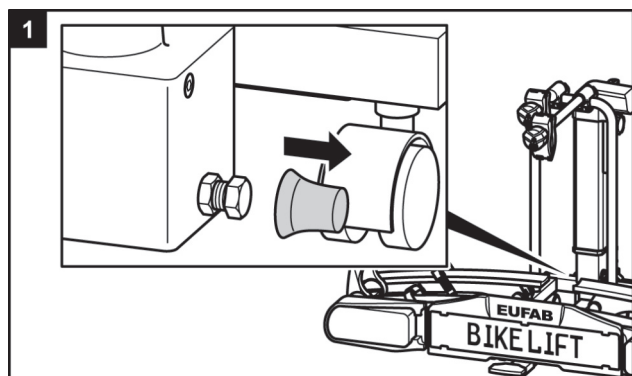

Élimination

Respectez les règles officielles locales pour l'élimination de déchets. Éliminez l'emballage dans les collecteurs prévus à cet effet.

Pour obtenir de plus amples renseignements, veuillez-vous adresser à votre centre d'élimination de déchets communal.

Contact

EAL GmbH
OttoHausmannRing 107
42115 Wuppertal
ALLEMAGNE

Téléphone : +49 (0) 202 4292830
Fax : +49 (0) 202 42928320
Courriel : info@ealvertrieb.com

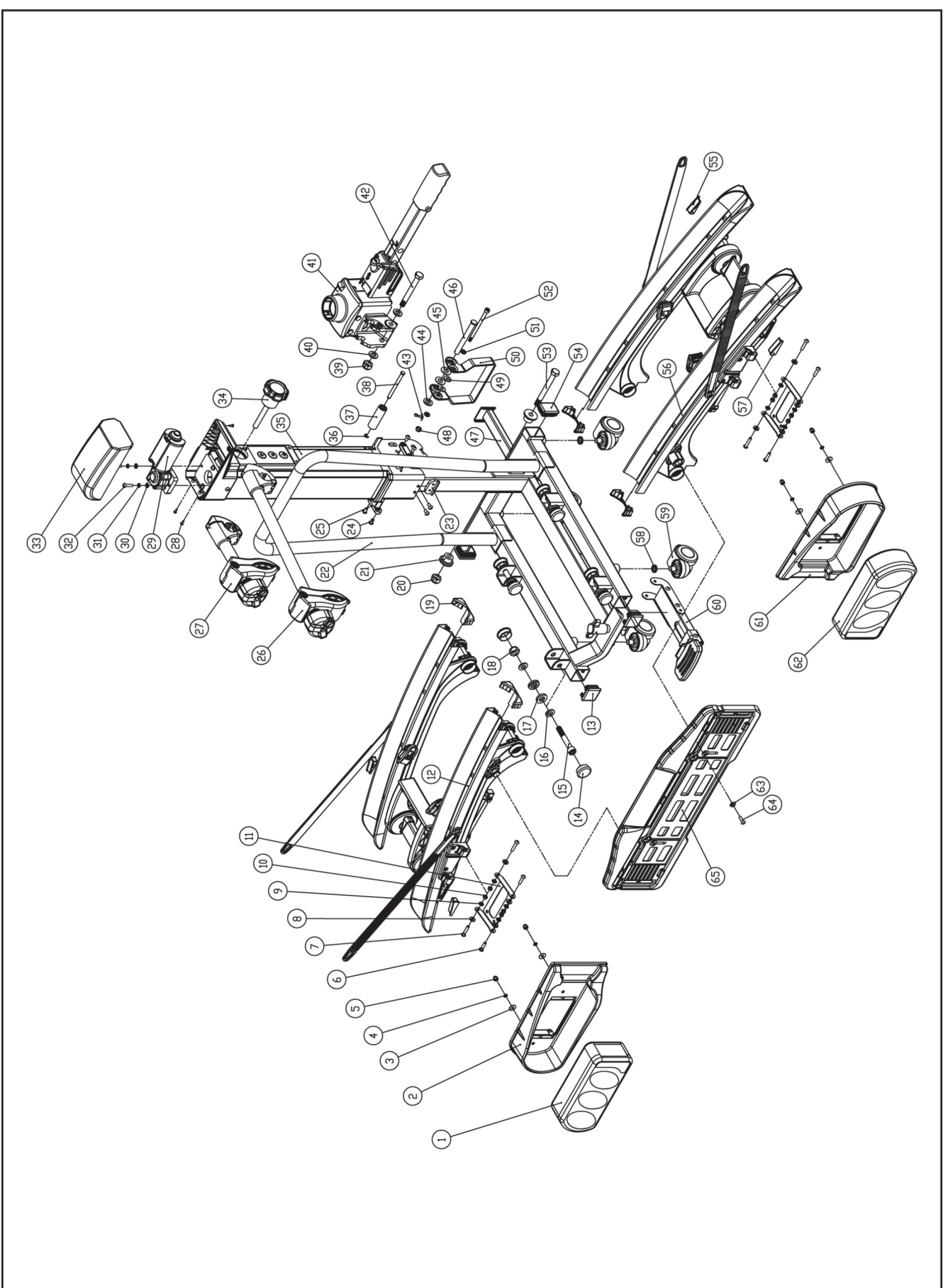

Pos.	Menge	Bezeichnung
1	1	Lamp complete right
2	1	Lamp guard right
3	4	Washer M5
4	4	Spring washer M5
5	4	Capped nut M5
6	4	Screw M5X20
7	4	Screw M5X25
8	8	Nylon washer M5
9	8	Washer M5
10	8	Self-locking nut M5
11	2	Lamp countersink
12	1	Left wheel rail with tension belt and carrier handle
13	2	Stopper for Nr.22,35X35mm
14	8	Round stopper for Nr.12
15	4	Bolt M10X65
16	8	Washer M10
17	8	Nylon washer M10
18	4	Self-locking nut M10
19	4	End cap aluminium rail interior
20	1	Self-locking nut M10
21	2	Stopper bearing pad
22	1	Carrier table bracket and U-bracket
23	1	Small plastic stopper 1
24	6	Screw M5X10
25	2	Small plastic stopper 2
26	1	Lock bracket long
27	1	Lock bracket short
28	4	Screw ST 2.9X9.5
29	1	Motor
30	2	Washer M5
31	2	Spring washer M5
32	2	Screw M5X20
33	1	Plastic cover for lift bracket

Pos.	Menge	Bezeichnung
34	1	Safety pin
35	1	Lift bracket
36	1	Jump ring
37	1	Nylon roller
38	1	Pin ø6
39	1	Self-locking nut M10
40	2	Washer M10-2.0
41	1	quick release
42	1	Bolt M10X87
43	1	Split pin ø3.2X25
44	2	Washer M10-2.0
45	2	Big washer M10-1.2
46	1	Pin ø10
47	1	Push rod
48	1	Self-locking nut M6
49	2	Big washer M6-1.2
50	1	Tilting operator
51	2	Washer M6-1.6
52	1	Bolt M6X85
53	1	Bolt M10X95
54	2	Stopper for Nr.22,30X40mm
55	2	Triangle end cap 1
56	1	right wheel rail with tension belt and carrier handle
57	2	Triangle end cap 2
58	4	Spring washer M10
59	4	Universal castor
60	1	Kick plate for locking mechanism
61	1	Lamp guard left
62	1	Lamp complete left
63	1	Nylon washer M5
64	1	Screw M5X16
65	1	Registration plate bracket

Affectation de connecteur

Le porte-vélo est équipé d'un système d'éclairage. Celui-ci est connecté à la prise d'accouplement de remorque avec une fiche 13 pôles. Si votre véhicule n'est pourvu que d'un raccordement 7 pôles au lieu de 13, les occupations correspondantes figurent ci-dessous. Cette information n'est destinée qu'à l'adaptation dans une entreprise spécialisée. Toute adaptation faite par une personne non qualifiée n'est pas autorisée.

13 Pin

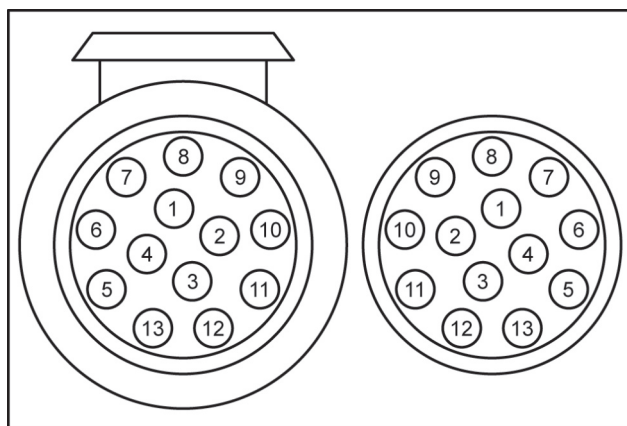

1	Clignotant gauche	jaune
2	Feu antibrouillard	bleu
3	Masse	blanc
4	Clignotant droit	vert
5	Feu arrière droit	brun
6	Feu stop	rouge
7	Feu arrière gauche	noir
8	Feu de recul	gris
9	+12 V pour système Lift	rouge
10	Non démontré	–
11	Non démontré	–
12	Non démontré	–
13	0 masse pour système Lift	noir

Portabiciclette Bike Lift

Istruzioni per l'uso

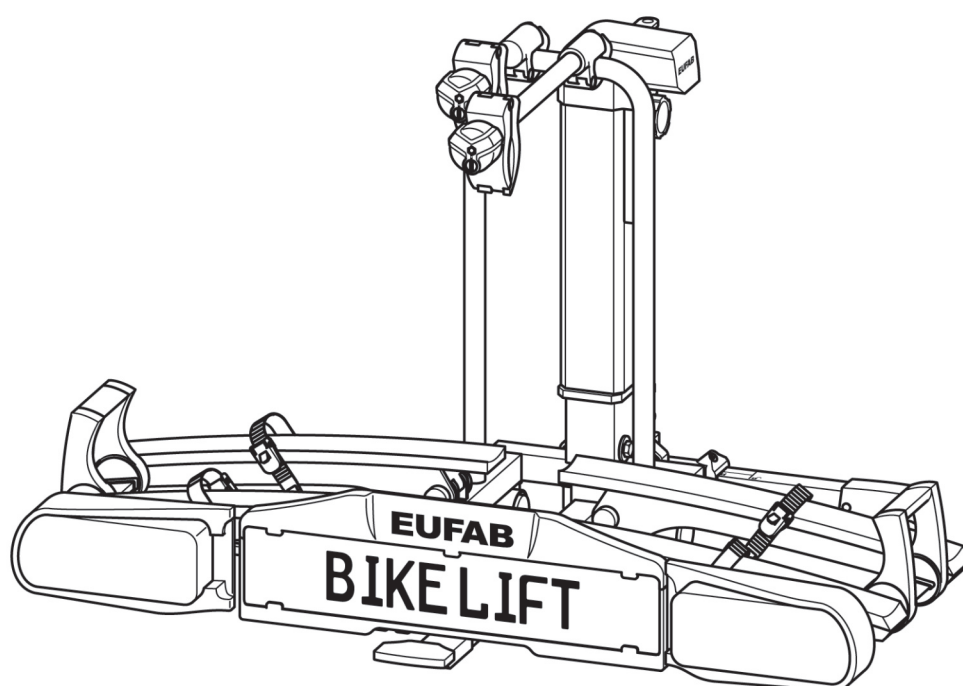

Bike Lift
Cod. art. 11535

Contenuto

Informazioni sulle presenti istruzioni per l'uso.....	75
Premessa.....	75
Obblighi relativi all'utilizzo delle presenti istruzioni per l'uso.....	75
Uso previsto.....	75
Spiegazioni relative alle indicazioni di sicurezza.....	75
Volume di consegna.....	76
Dati tecnici.....	76
Requisiti del gancio di traino.....	76
Indicazioni di sicurezza.....	77
Prima della prima messa in funzione.....	78
Montaggio della targa sul portabici.....	78
Montaggio e uso.....	79
Montaggio del portabici sul gancio di traino.....	79
Sollevamento manuale del portabici sul gancio di traino.....	80
Sollevamento del portabici sul gancio di traino con motore integrato.....	81
Abbassamento e sollevamento del portabici.....	84
Abbassamento del portabici.....	84
Sollevamento e fissaggio del portabici.....	85
Fissaggio delle biciclette.....	86
Ripiegamento del portabici, accesso al bagagliaio.....	90
Smontaggio del portabici.....	91
Trasporto e stivaggio.....	92
Pulizia e cura.....	92
Manutenzione.....	93
Smaltimento.....	93
Contatto.....	93
Rimorchio.....	94
Panoramica dei pezzi di ricambio (disegno scomposto).....	94
Panoramica dei pezzi di ricambio (tabella).....	95
Configurazione dei connettori, 13 poli.....	96

Informazioni sulle presenti istruzioni per l'uso

Premessa

Queste istruzioni forniscono informazioni

- sull'uso previsto
- sull'impiego sicuro del portabici Bike Lift.

Obblighi relativi all'utilizzo delle presenti istruzioni per l'uso

Ogni persona impegnata nelle operazioni di

- montaggio,
- pulizia o
- smaltimento

di questo portabici, deve aver letto e compreso il contenuto delle istruzioni per l'uso complete.

Conservare le presenti istruzioni in un luogo sicuro, sempre a portata di mano. In caso di cessione a terzi del portabici, consegnare anche le presenti istruzioni per l'uso.

Usò previsto

Il portabici Bike Lift è destinato al trasporto di max. due biciclette. Può essere montato esclusivamente sui ganci di traino, le cui caratteristiche soddisfino i presupposti indicati nel capitolo Requisiti del gancio di traino.

Inoltre, il carico utile consentito per il portabici non deve mai essere sperato. Rientra nell'uso conforme anche il rispetto di tutte le informazioni fornite nelle presenti istruzioni per l'uso, in particolare l'osservanza delle indicazioni di sicurezza. Ogni altro impiego è da considerarsi improprio e può causare danni materiali o lesioni personali.

EAL GmbH non risponde per i danni derivanti da un uso improprio.

Spiegazioni delle indicazioni di sicurezza

Nelle istruzioni sono riportate le seguenti categorie relative alle indicazioni di sicurezza:



PERICOLO

Le indicazioni precedute dalla parola chiave PERICOLO indicano un pericolo grado di rischio elevato.

Se il pericolo non viene evitato, ne conseguono lesioni gravi e/o la morte.



AVVERTENZA

Le indicazioni precedute dalla parola chiave AVVERTENZA indicano un pericolo imminente con grado di rischio medio.

Se il pericolo non viene evitato, ne possono conseguire lesioni gravi e/o la morte.



PRUDENZA

Le indicazioni precedute dalla parola chiave PRUDENZA indicano un pericolo imminente con grado di rischio basso.

Se il pericolo non viene evitato, ne possono conseguire lesioni di media o lieve entità.



ATTENZIONE

Le indicazioni precedute dalla parola chiave ATTENZIONE indicano un pericolo imminente di danni materiali.

Se il pericolo non viene evitato, il prodotto o qualcosa nei dintorni potrebbe subire dei danni.



NOTA

Altre note:

Consiglio utile. Facilita l'uso o il montaggio del prodotto oppure ne semplifica la comprensione.

Il simbolo di sicurezza utilizzato non sostituisce il testo dell'indicazione di sicurezza.

Pertanto, leggere attentamente e rispettare alla lettera l'indicazione di sicurezza!

Volume di consegna

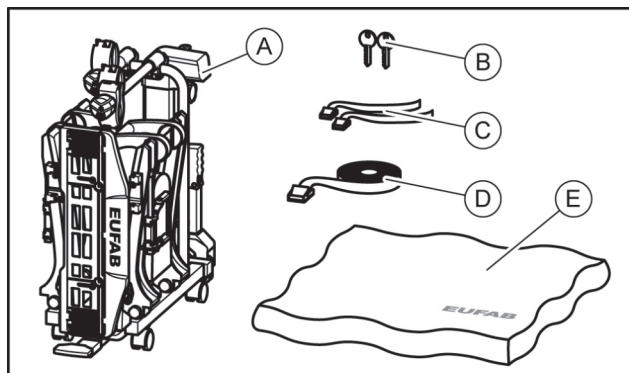

- A = portabiciclette
- B = 2 chiavi
- C = 2 cinghie di fissaggio per ruote anteriori
- D = 1 cinghia di fissaggio per telaio
- E = involucri di protezione

Dati tecnici

Materiale:	Alluminio Acciaio Plastica
Peso a vuoto:	25 kg
Carico utile, max.:	60 kg
Consumo di corrente medio:	2 A
Consumo di corrente massimo:	5,5 A
Dimensioni (LarxAltxPro), minime:	30 × 74 × 74 cm
Dimensioni (LarxAltxPro), massime:	135 × 74 × 74 cm
Dimensioni imballaggio (LarxAltxPro):	81 × 77 × 33 cm

Non superare il carico utile max. del portabiciclette e il carico d'appoggio consentito per il gancio di traino. Il peso totale e il carico per asse ammessi per il veicolo non devono essere superati dal portabiciclette e dal carico.

Esempi di Bike Lift

Max. carico d'appoggio sul punto d'aggancio	Peso a vuoto del portabiciclette	Max. carico utile sul portabiciclette
50 kg	25 kg	25 kg
60 kg	25 kg	35 kg
75 kg	25 kg	50 kg
90 kg	25 kg	max. 60 kg !

Requisiti del gancio di traino



PERICOLO

Pericolo di lesioni personali per la rottura del gancio di traino.

Il montaggio del portabiciclette su un gancio di traino realizzato con un materiale troppo morbido, potrebbe causare la rottura del gancio.

- ⇒ Montare il portabiciclette solo su un gancio di traino in acciaio St52, ghisa grigia GG52 o di qualità migliore.
- ⇒ Non montare mai il portabiciclette su un gancio di traino realizzato in alluminio, altri metalli leggeri o materia plastica.

Requisiti del gancio di traino

Montare il portabiciclette solo sui ganci di traino con le seguenti caratteristiche:

Materiale: almeno acciaio St52 o ghisa grigia GG52

Valore D: $\geq 7,6$ kN

Rispettare le indicazioni del produttore del gancio di traino.

Indicazioni di sicurezza

Seguire attentamente le istruzioni di montaggio. Il mancato rispetto delle istruzioni può causare lesioni personali e danni materiali.

In caso di dubbio durante il montaggio, rivolgersi al proprio rivenditore o al costruttore per maggiori informazioni.

Il costruttore e il rivenditore non rispondono per eventuali danni imputabili ad un uso improprio o un montaggio errato.

Controllare regolarmente il portabici e il relativo carico! Si tratta di un obbligo a cui attenersi e di cui si risponde in caso di danni.



NOTA

Per questo portabici esiste un'omologazione europea, che è allegata al portabici e deve essere portata con sé durante l'uso.



NOTA

Durante la guida con il portabici montato, si applicano le norme e le disposizioni di legge sul trasporto di merci dietro il veicolo.



AVVERTENZA

Viaggiare con il portabici influisce sul comportamento su strada del veicolo.

Lesioni personali o danni materiali in seguito a un diverso comportamento su strada del veicolo.

- ⇒ Adeguare la velocità del veicolo al diverso comportamento su strada.
- ⇒ Non viaggiare mai a più di 130 km/h.
- ⇒ Evitare sterzate improvvise e brusche.
- ⇒ Considerare che il veicolo è più lungo del normale.



AVVERTENZA

Eventuali parti sporgenti oltre il bordo del veicolo e/o del portabici possono causare lesioni personali o danni materiali durante la marcia.

Lesioni personali o danni materiali in seguito a parti sporgenti.

- ⇒ Montare solo parti che non sporgano oltre il bordo del veicolo.



AVVERTENZA

Il superamento del massimo carico utile del portabici e del carico d'appoggio consentito sul punto d'aggancio o del peso totale consentito, può causare incidenti gravi.

Lesioni personali o danni materiali in seguito a un carico eccessivo.

- ⇒ Rispettare tassativamente le indicazioni relative al massimo carico utile, al massimo carico d'appoggio consentito e al peso totale del veicolo. Non superare mai questi valori.



AVVERTENZA

Viaggiare senza cinghie di fissaggio può causare incidenti.

Lesioni personali o danni materiali in seguito alla perdita delle biciclette.

- ⇒ Prima di iniziare il viaggio, verificare che la cinghia sia fissata correttamente intorno alle biciclette e alla staffa a U del portabici (vedere il capitolo

Fissaggio delle biciclette).

- ⇒ Prima di iniziare il viaggio, verificare il corretto fissaggio delle due cinghie intorno alla ruota anteriore e della cinghia intorno alla ruota posteriore della bicicletta.
- ⇒ Tendere ulteriormente le cinghie all'occorrenza.
- ⇒ Prima di iniziare il viaggio, assicurarsi che le cinghie utilizzate non siano danneggiate o usurate.
- ⇒ Prima di iniziare il viaggio, le cinghie danneggiate o usurate devono essere sostituite con altre in perfetto stato. È consentito solo utilizzare cinghie omologate da EAL GmbH.



AVVERTENZA

Viaggiare con il portabici ripiegato può causare incidenti. Le parti mobili del portabici, se non completamente montate, rappresentano una fonte di pericolo.

Pericolo di lesioni personali o danni materiali in seguito al portabici non completamente montato.

- ⇒ Smontare il portabici quando non lo si utilizza.
- ⇒ Non viaggiare mai con il portabici ripiegato.



AVVERTENZA

I teloni di copertura aumentano la resistenza dell'aria. Possono allentarsi e svolazzare e ciò può causare gravi incidenti.

Lesioni personali e danni materiali a causa dei teloni di copertura.

⇒ Non utilizzare teloni.



AVVERTENZA

Il portabiciclette si posiziona esattamente sul gancio di traino dopo il fissaggio e dopo la percorrenza di alcuni chilometri.

Lesioni personali o danni materiali in seguito alla perdita del portabiciclette.

⇒ Dopo alcuni chilometri, controllare che il portabiciclette sia fissato saldamente.

⇒ In caso di allentamento, ripetere il montaggio.



AVVERTENZA

La guida con il portabiciclette montato su terreni impervi può portare al distacco dello stesso.

Lesioni personali o danni materiali in seguito al distacco del portabiciclette.

⇒ Non utilizzare il portabiciclette su terreni impervi.



ATTENZIONE

Il portellone posteriore potrebbe sbattere contro il portabiciclette e subire dei danni.

Danni materiali per l'apertura del portellone posteriore.

⇒ Disinserire il comando elettrico del portellone posteriore e impostare l'azionamento manuale.

⇒ Ripiegare il portabiciclette prima di aprire il portellone posteriore.



ATTENZIONE

Se il portabiciclette e/o le biciclette sono troppo vicini allo scappamento, possono subire danni.

Danni materiali causati da gas di scarico caldi.

⇒ Se necessario, utilizzare un terminale di scarico.

Prima della prima messa in funzione

Montaggio della targa sul portabiciclette

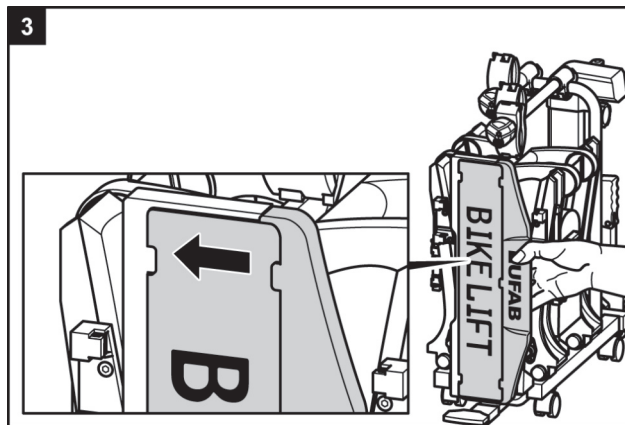
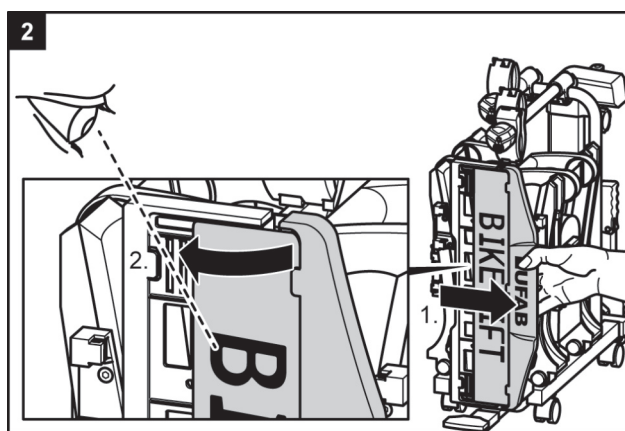
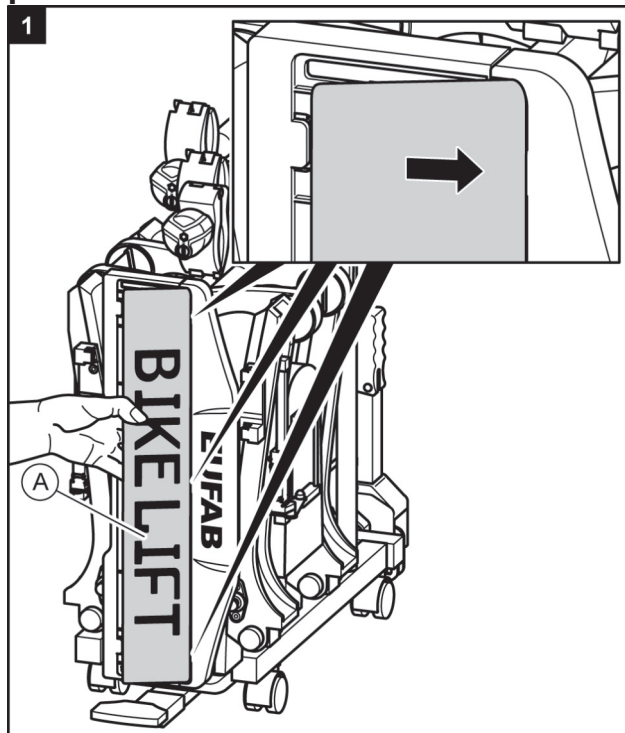

Montaggio e uso

Montaggio del portabiciclette sul gancio di traino

- ⇒ superficie piana. Tirare il freno
- ⇒ a mano.

Diverse possibilità di montaggio

Il portabiciclette può essere montato in due modi diversi sul gancio di traino.

1. Sollevamento manuale del portabiciclette sul gancio di traino
Vantaggio: montaggio rapido.
Svantaggio: serve una forza maggiore rispetto al montaggio con motore integrato.
⇒ Seguire i passi 1-6 e 17 - 23 descritti in questo capitolo.
2. Lift the bicycle carrier onto the tow hitch using the integrated motor.
Advantage: Only minimal effort required
Disadvantage: Longer fitting time compared with manual fitting.
⇒ Follow steps 1 – 2 and 7 – 23 in this chapter.



AVVERTENZA

Eventuali danni al portabiciclette, ad es. causati da parti piegate, crepe o graffi, pregiudicano il funzionamento sicuro del portabiciclette.

Lesioni personali o danni materiali in seguito a un portabiciclette danneggiato.

- ⇒ Non montare il portabiciclette, se danneggiato.
- ⇒ Procedere come descritto nel capitolo Manutenzione.



AVVERTENZA

Un collegamento non corretto o difettoso tra portabiciclette e gancio di traino può causare il distacco del portabiciclette.

Lesioni personali o danni materiali in seguito alla perdita del portabiciclette durante il viaggio.

- ⇒ Sostituire il gancio di traino se difettoso.
- ⇒ Eliminare sporco, polvere e grasso dal gancio di traino.



NOTA

La sfera del gancio di traino è spesso ricoperta da uno strato di vernice. Per garantire la migliore tenuta possibile del portabiciclette, è consigliabile rimuovere con cautela questo strato di vernice. Rispettare le indicazioni del produttore del gancio di traino.

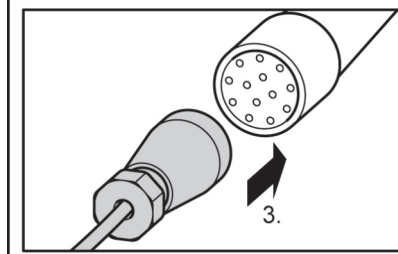
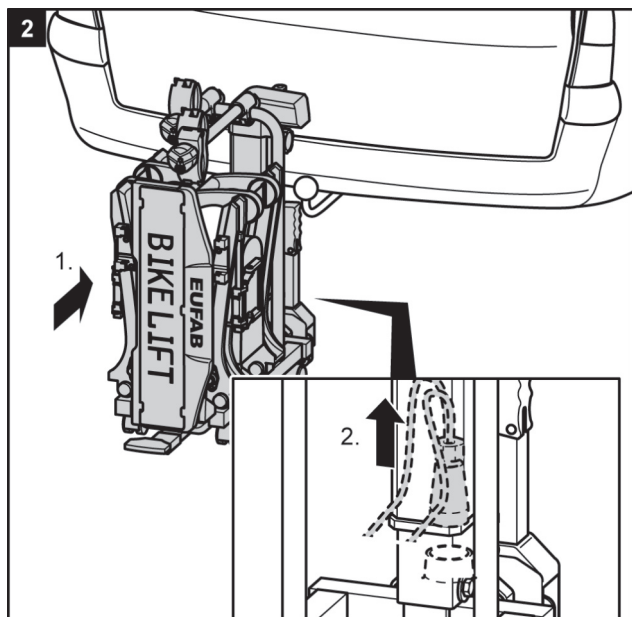
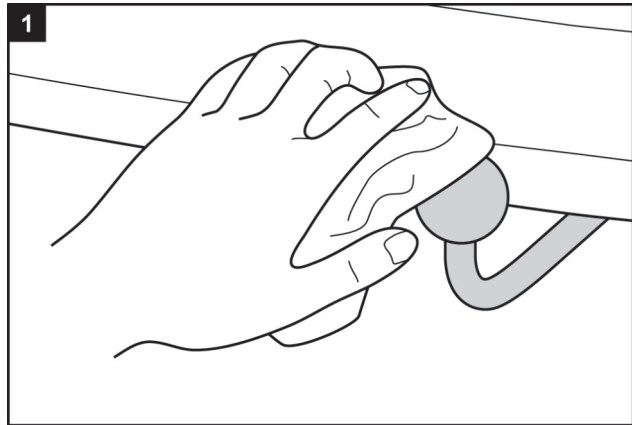

- ⇒ **3** Per il sollevamento manuale, seguire il passo di lavoro descritto di seguito.
- ⇒ **7** Per il sollevamento tramite motore integrato, seguire i passi di lavoro a partire dal numero 7

Sollevamento manuale del portabiciclette sul gancio di traino.

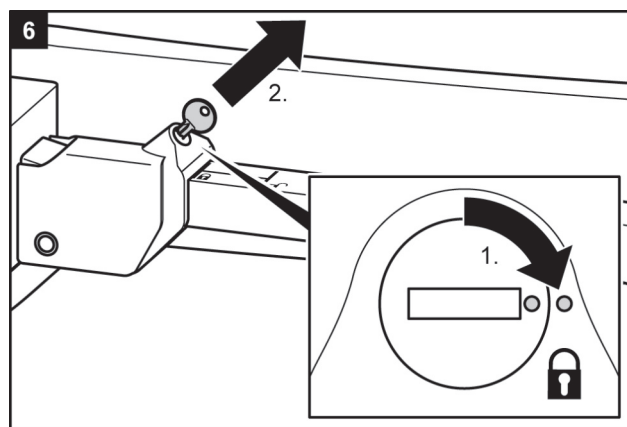
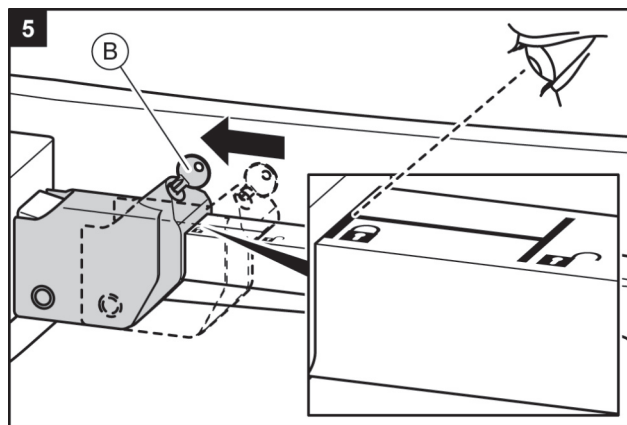
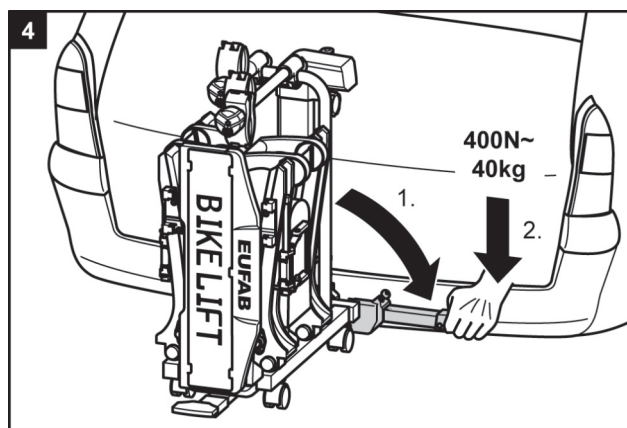
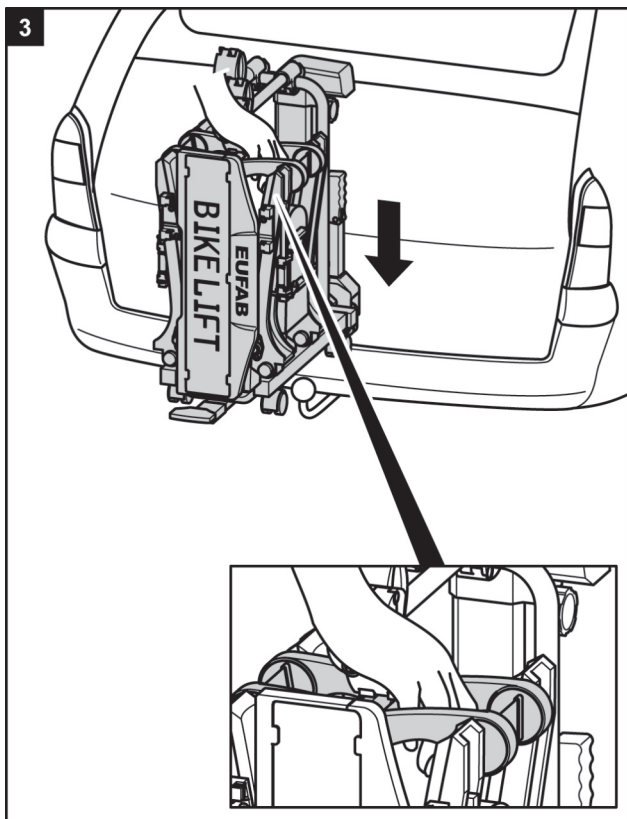

WARNING

Se la leva non si blocca con la chiusura a chiave, il portabiciclette potrebbe staccarsi dal veicolo durante il viaggio.

Lesioni personali o danni materiali in seguito a un portabiciclette non bloccato.

- ⇒ Chiudere a chiave il portabiciclette.
 - ⇒ Controllare se la leva è chiusa a chiave e se la chiave è stata estratta.
- La chiusura a chiave previene anche un eventuale furto del portabiciclette.



AVVERTENZA

Un collegamento lasco tra il portabiciclette e il gancio di traino può causare il distacco del portabiciclette.

Lesioni personali o danni materiali in seguito alla perdita del portabiciclette durante il viaggio.

- ⇒ Controllare che il portabiciclette sia fissato saldamente.
- ⇒ Se il fissaggio è lento, seguire i passi di lavoro da 3 a 6. Se la situazione non migliora, può essere necessario regolare l'aggancio rapido, come illustrato al capitolo Manutenzione.

- ⇒ **17** Da questo punto, seguire il passo 17 descritto in questo capitolo.

Sollevamento del portabiciclette sul gancio di traino con motore integrato

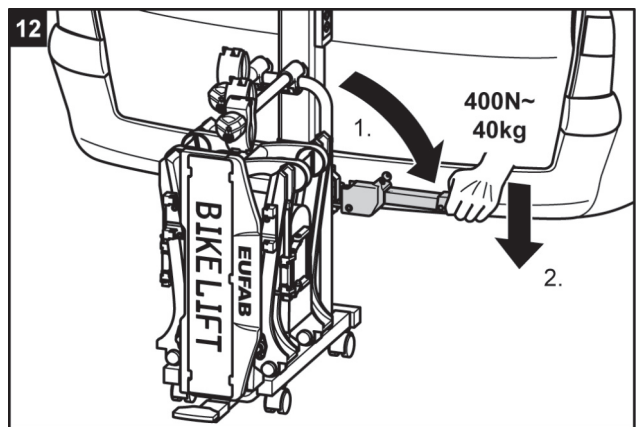
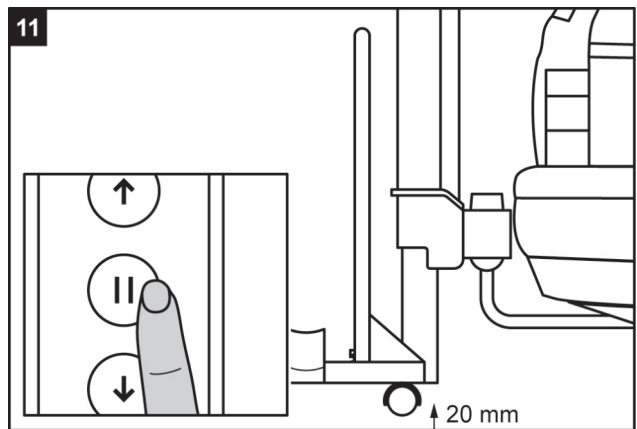
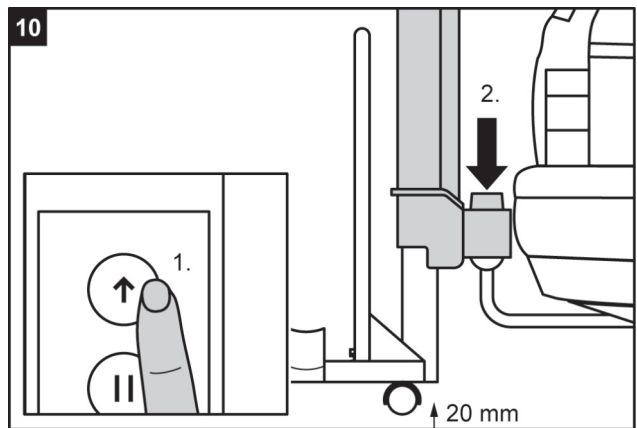
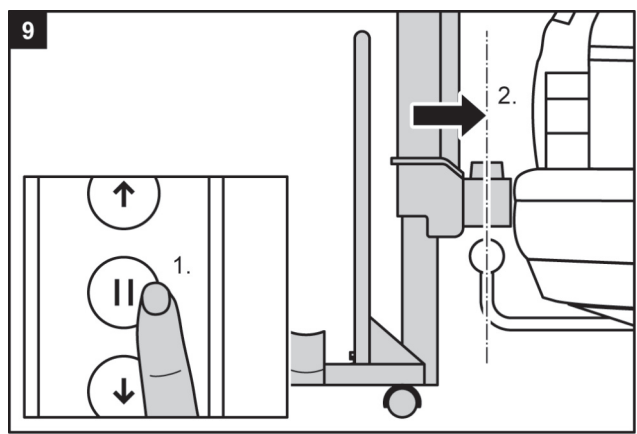
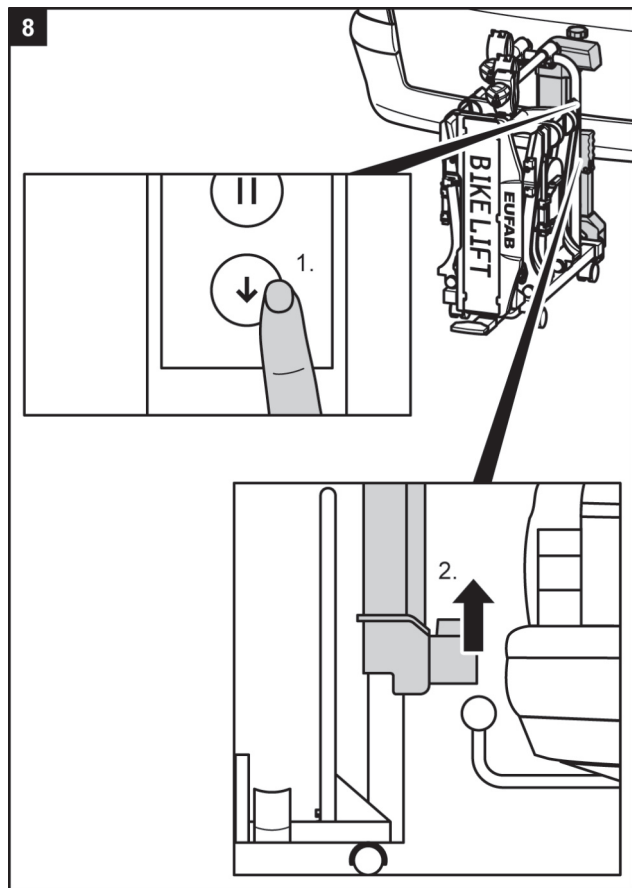
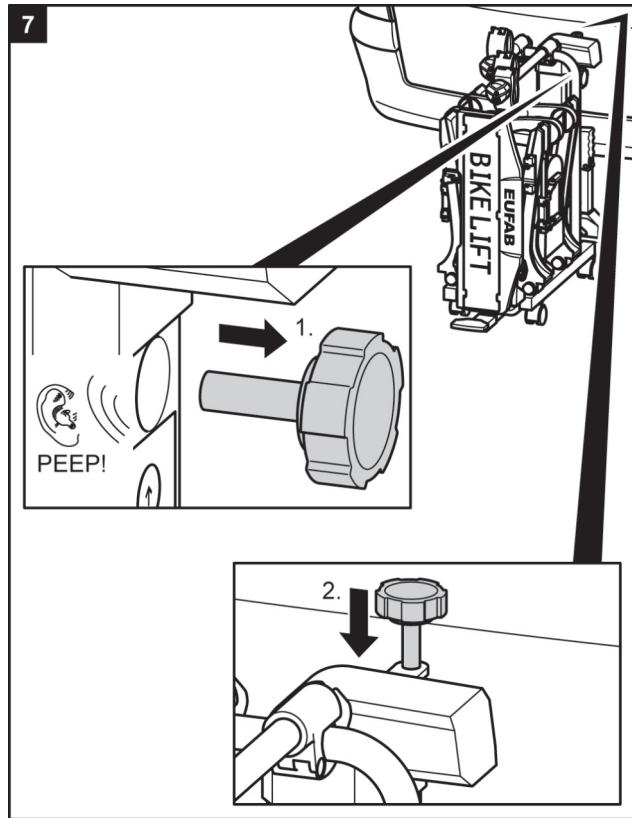

I Montaggio del portabiciclette sul gancio di traino

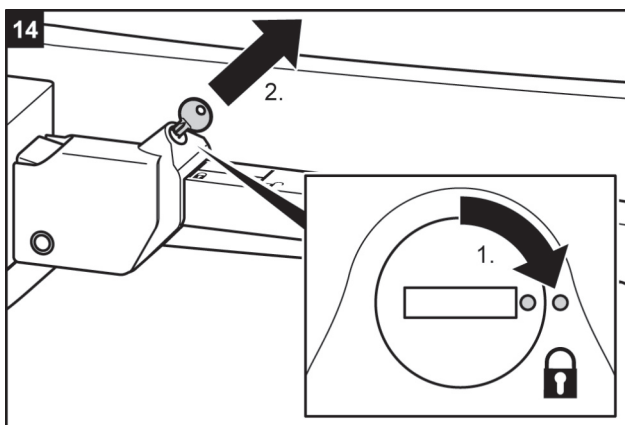
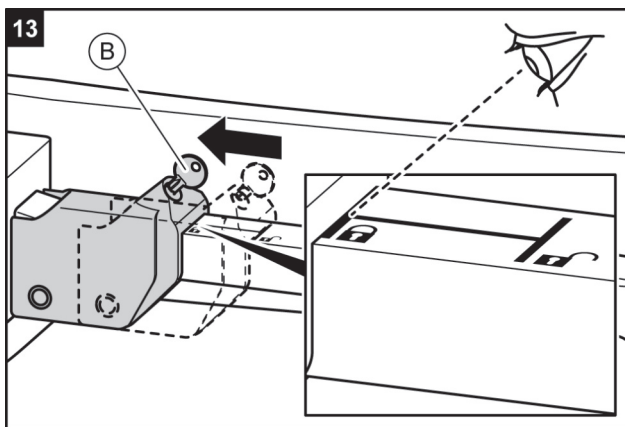

AVVERTENZA

Se la leva non si blocca con la chiusura a chiave, il portabiciclette potrebbe staccarsi dal veicolo durante il viaggio.

Lesioni personali o danni materiali in seguito a un portabiciclette non bloccato.

- ⇒ Chiudere a chiave il portabiciclette.
- ⇒ Controllare se la leva è chiusa a chiave e se la chiave è stata estratta.

La chiusura a chiave previene anche un eventuale furto del portabiciclette.



AVVERTENZA

Un collegamento lasco tra il portabiciclette e il gancio di traino può causare il distacco del portabiciclette.

Lesioni personali o danni materiali in seguito alla perdita del portabiciclette durante il viaggio.

- ⇒ Controllare che il portabiciclette sia fissato saldamente.
- ⇒ Se il fissaggio è lento, seguire i passi da 1 a 14. Se la situazione non migliora, può essere necessario regolare l'aggancio rapido, come illustrato nel capitolo Manutenzione..

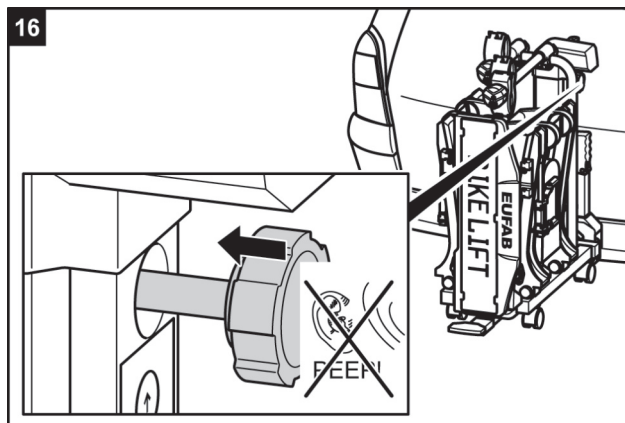
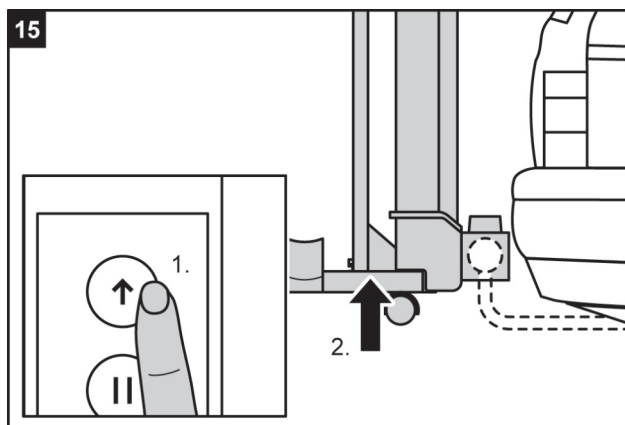

- ⇒ A partire dal passo successivo, la sequenza di montaggio per il sollevamento manuale e automatico è identica.

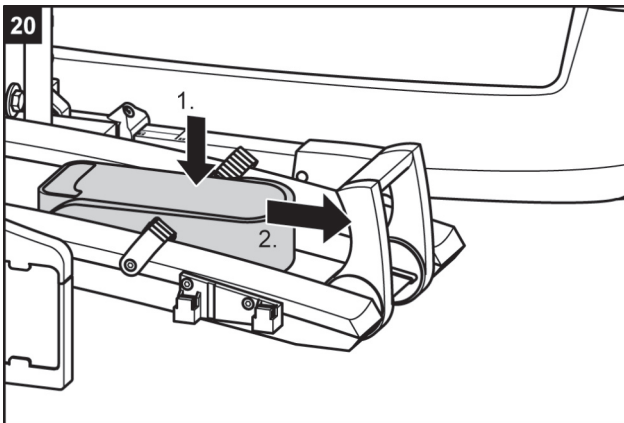
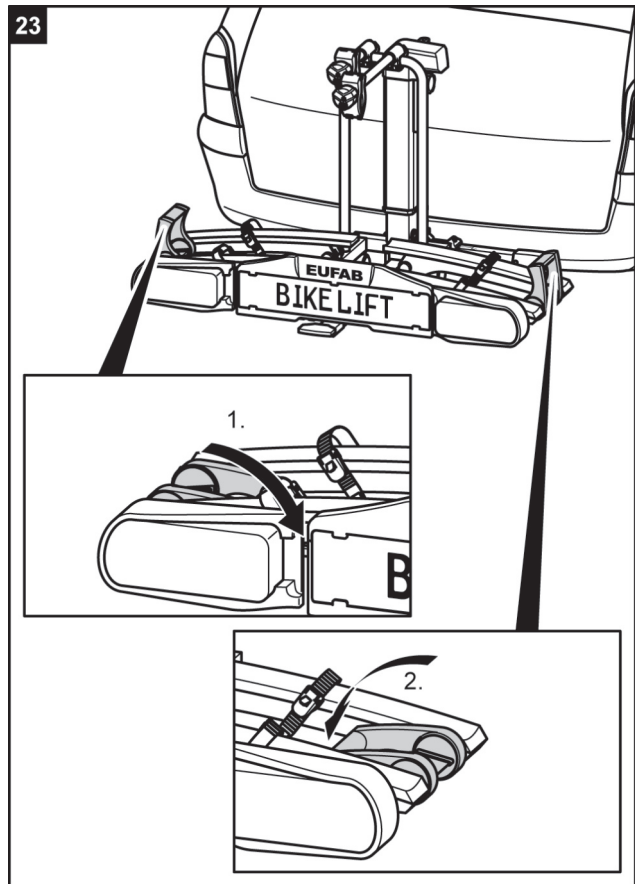
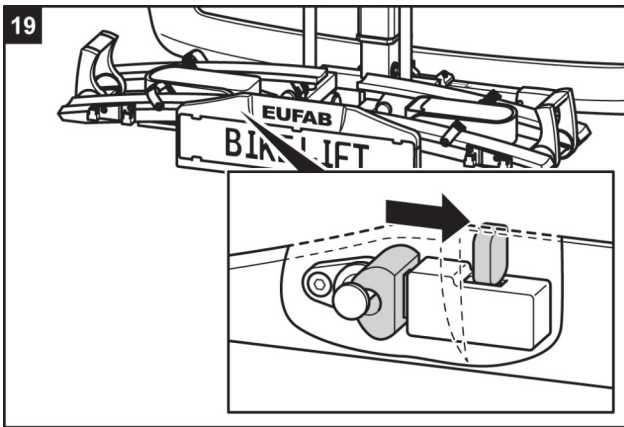
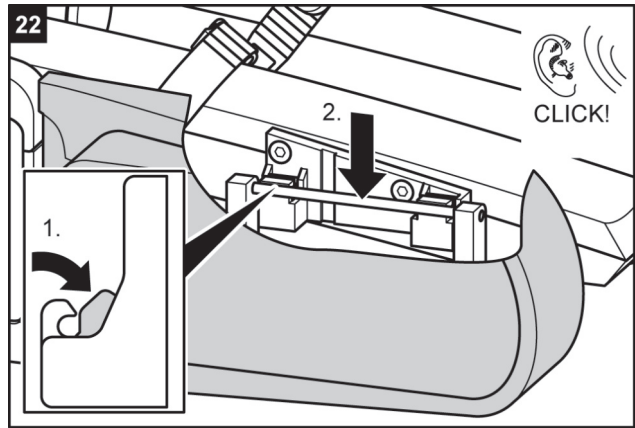
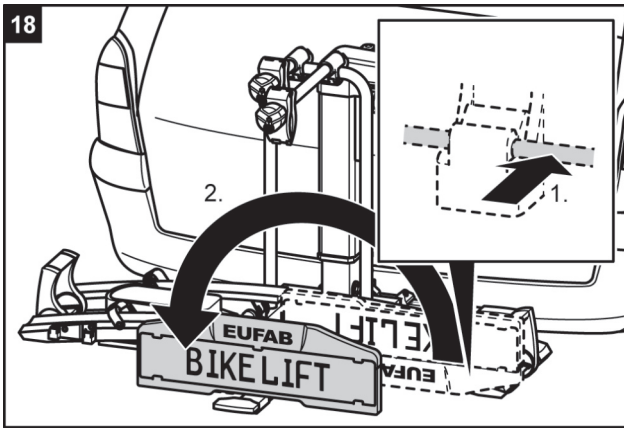
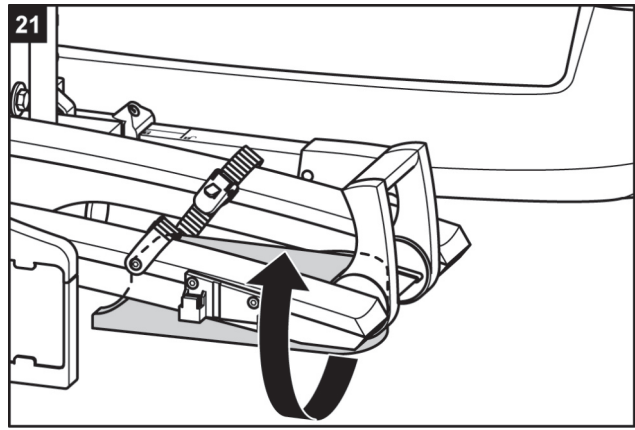
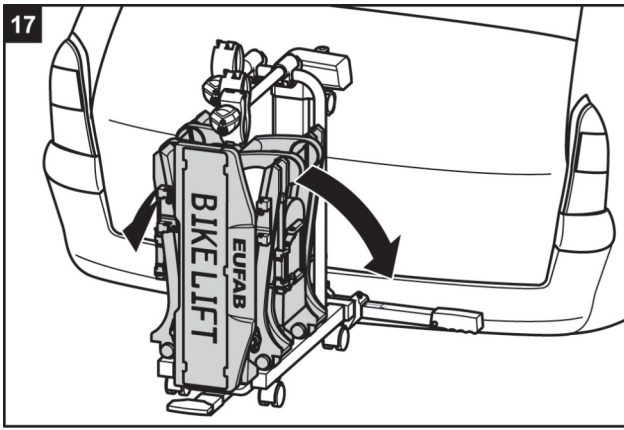



AVVERTENZA

Viaggiare senza un impianto di illuminazione funzionante può causare incidenti.

Lesioni personali o danni materiali perché il proprio veicolo non viene notato da altri utenti del traffico.

- ⇒ Prima di iniziare il viaggio, controllare se l'impianto di illuminazione funziona correttamente.
- ⇒ Sostituire eventuali lampadine difettose.
- ⇒ Controllare il collegamento tra connettore e gancio di traino.



PRUDENZA

Eventuali parti del corpo o oggetti che dovessero trovarsi sotto il portabiciclette, rischiano di essere schiacciate durante l'abbassamento

Lesioni personali o danni materiali in seguito all'abbassamento del portabiciclette.

- ⇒ Assicurarsi che sotto il portabiciclette non ci sia nulla.
- ⇒ Prestare attenzione al proprio corpo e mantenere una distanza di sicurezza.

Abbassamento e sollevamento del portabiciclette

Abbassamento del portabiciclette



AVVERTENZA

Un portabiciclette non sollevato o non fissato può restare impigliato a un ostacolo.

Lesioni personali o danni materiali in seguito alla perdita del portabiciclette durante il viaggio.

- ⇒ Prima di un viaggio, sollevare il portabiciclette fino alla posizione di fine corsa.
- ⇒ Fissare il portabiciclette con il perno di fissaggio, come indicato nel paragrafo "Sollevamento del portabiciclette".

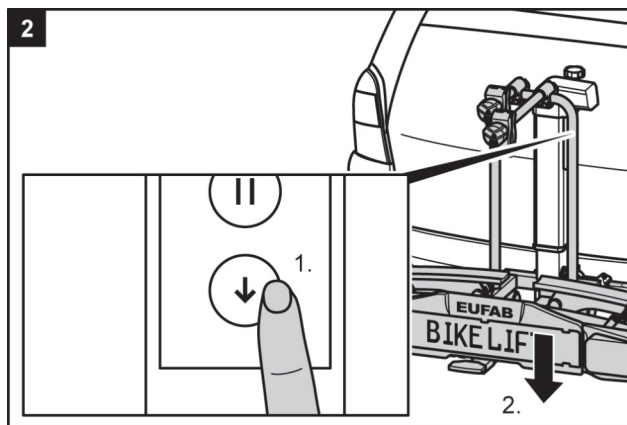
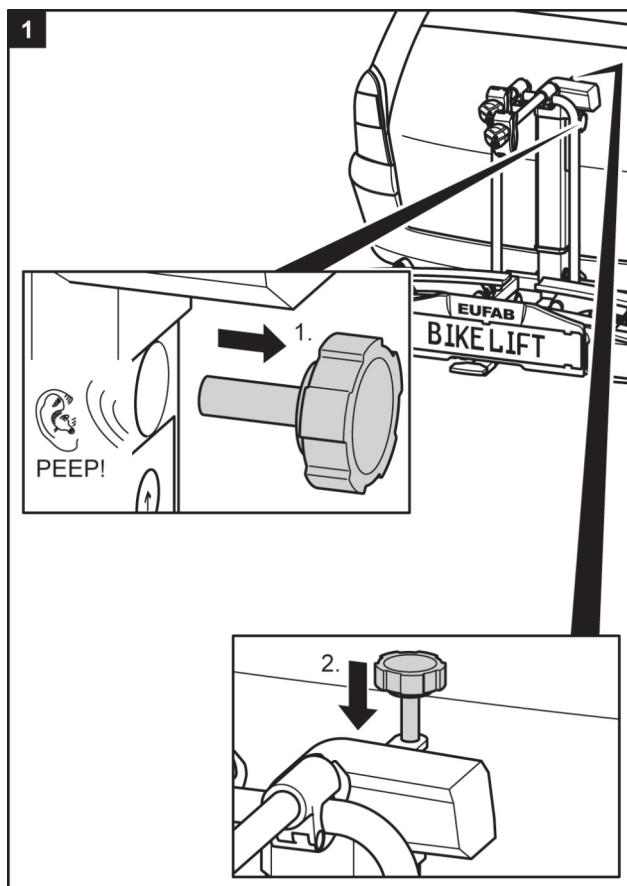

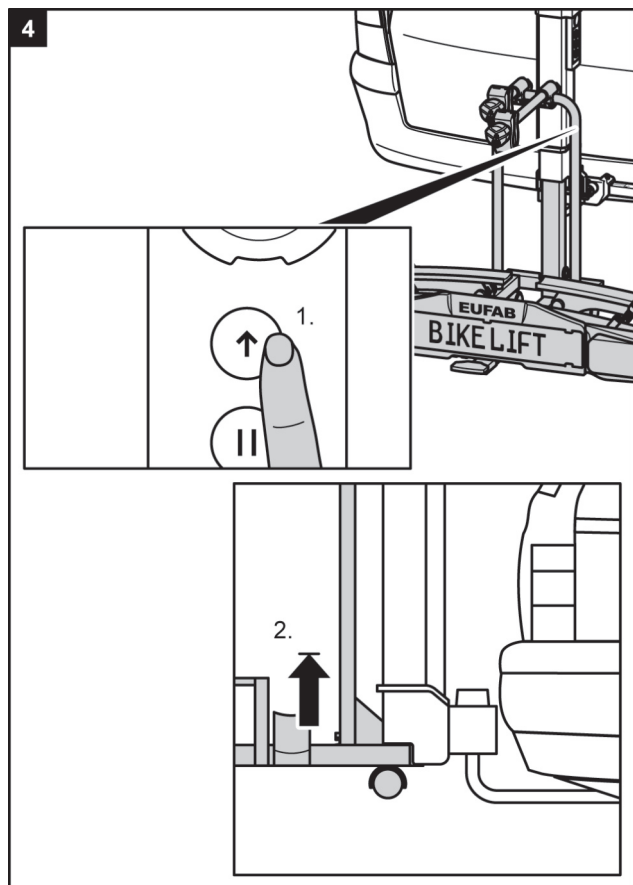
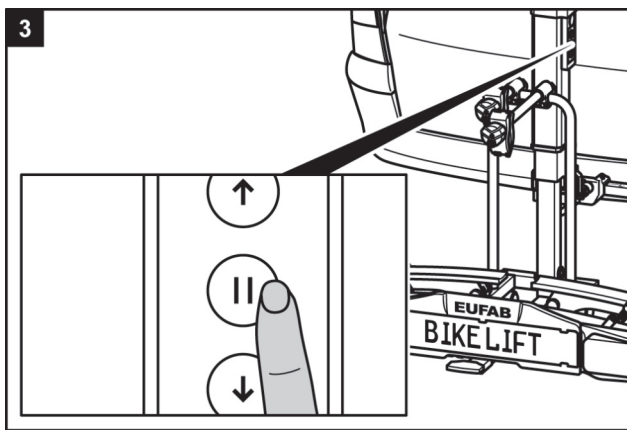

Sollevamento e fissaggio del portabiciclette

- ⇒ Sollevare il portabiciclette fino all'arresto.
- ⇒ Montare il perno di fissaggio.
Il perno di fissaggio può essere inserito solo se il portabiciclette si trova nella posizione di fine corsa superiore.
- ⇒ Dopo il montaggio del perno di sicurezza, l'avviso acustico si spegne.



AVVERTENZA

L'abbassamento del portabiciclette durante il viaggio può causare gravi incidenti.

Lesioni personali e danni materiali causati dall'abbassamento del portabiciclette durante il viaggio.

- ⇒ Assicurarsi che il perno di fissaggio sia completamente inserito dopo il sollevamento.
- ⇒ Se il perno non è completamente inserito alla partenza, scatta un segnale acustico.
- ⇒ Estrarre il perno di fissaggio, sollevare il portabiciclette fino all'arresto e infine inserire completamente il perno di fissaggio.

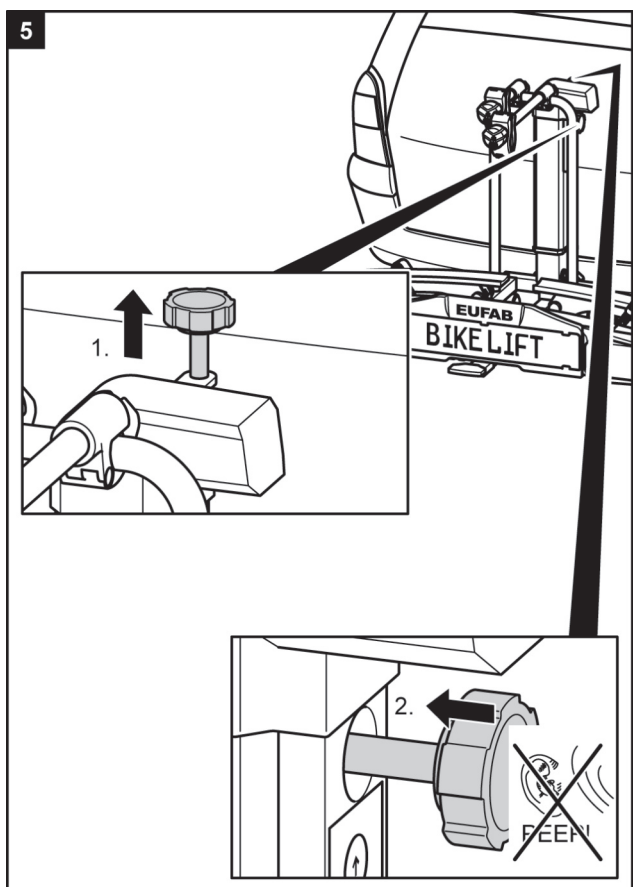

Fissaggio delle biciclette

⇒ Per prima cosa, abbassare la superficie di appoggio delle biciclette come descritto al capitolo Abbassamento del portabiciclette.



NOTA

In rari casi può accadere che il portabici non si possa aprire sufficientemente per essere spinto, come descritto nel punto 9, sopra la sfera del gancio di traino. In tal caso inclinare leggermente il portabici per raggiungere l'altezza necessaria sul giunto.



AVVERTENZA

Eventuali parti delle biciclette non avvitate saldamente possono staccarsi durante il viaggio.

Lesioni personali e danni materiali in seguito a parti volanti.

- ⇒ Rimuovere tutte le parti non fissate saldamente alla bicicletta come pompe, borse, navigatori, batterie o accumulatori.
- ⇒ Rimuovere anche tutte le parti che possano creare un'ulteriore resistenza all'aria, come cestini e seggiolini per bambini.



NOTA

Per migliorare il comportamento su strada del proprio veicolo, si consiglia di montare per prima la bicicletta più pesante.

Inoltre, se si carica una sola bicicletta, utilizzare il binario più vicino alla parte posteriore del veicolo.

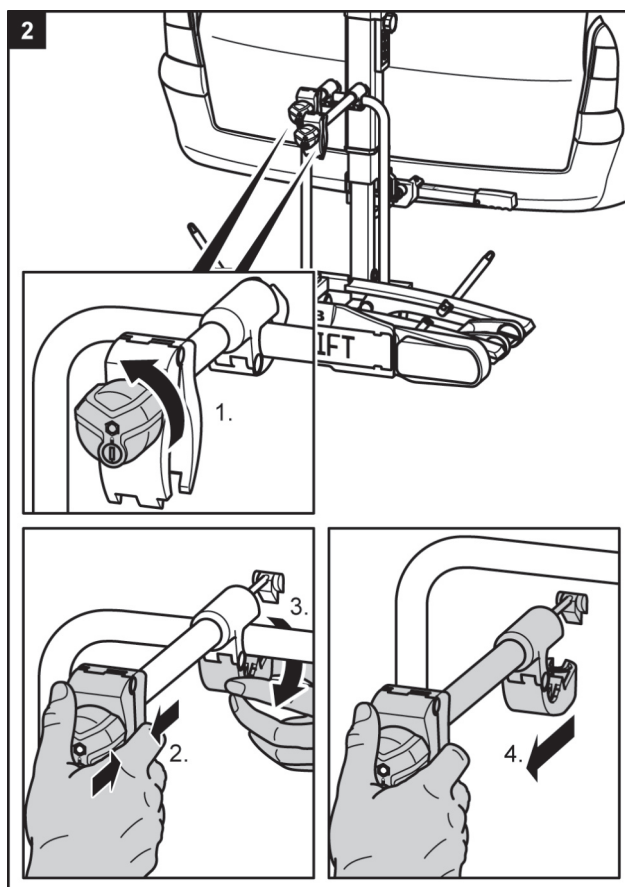
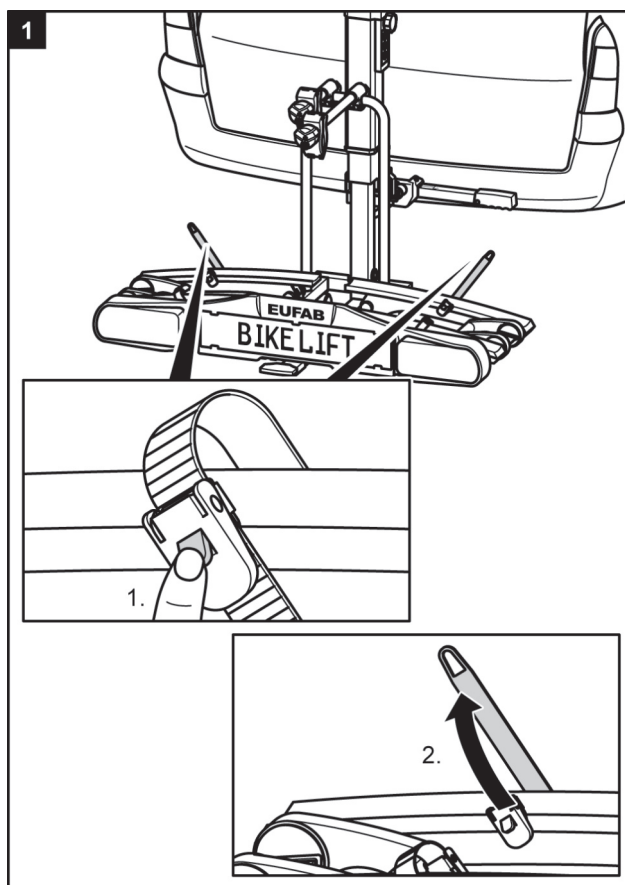

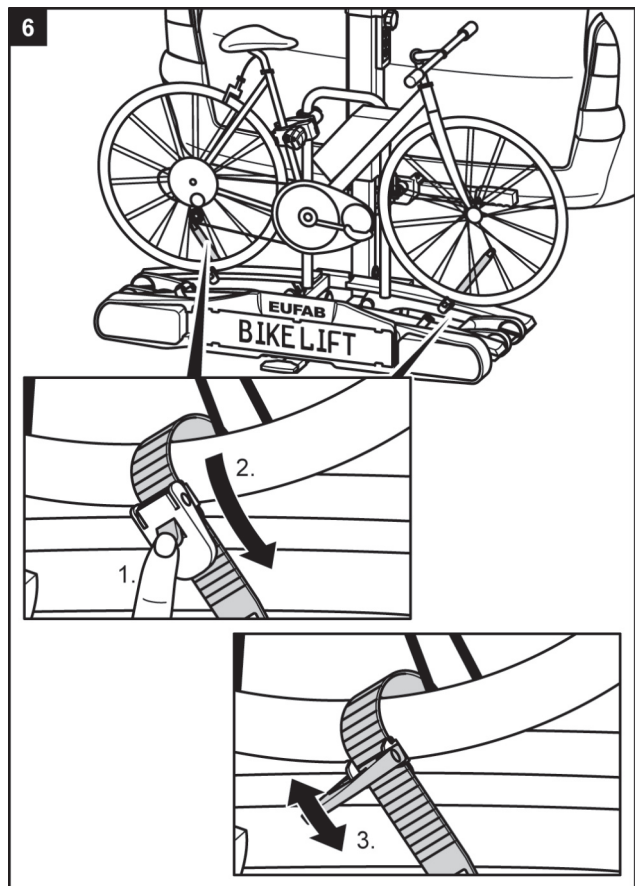
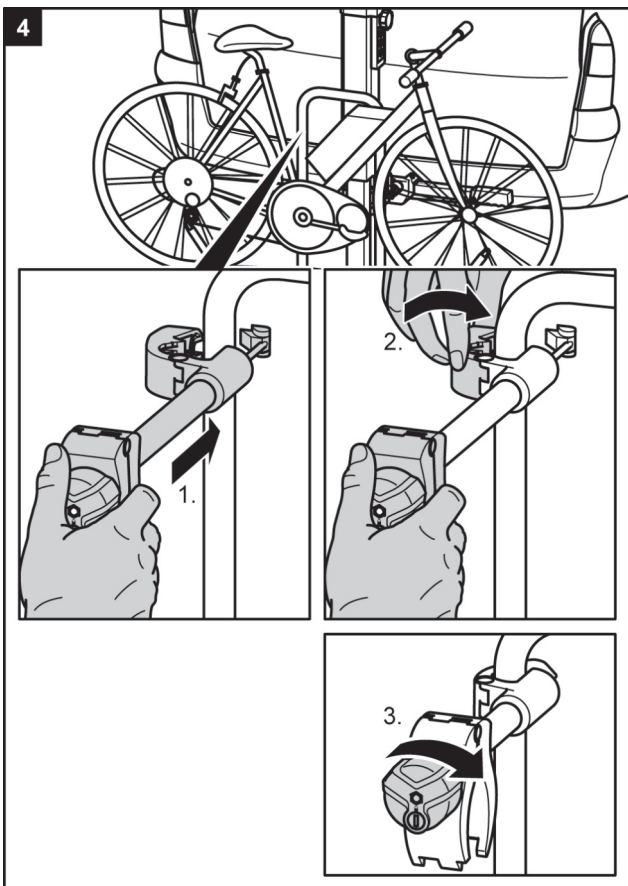
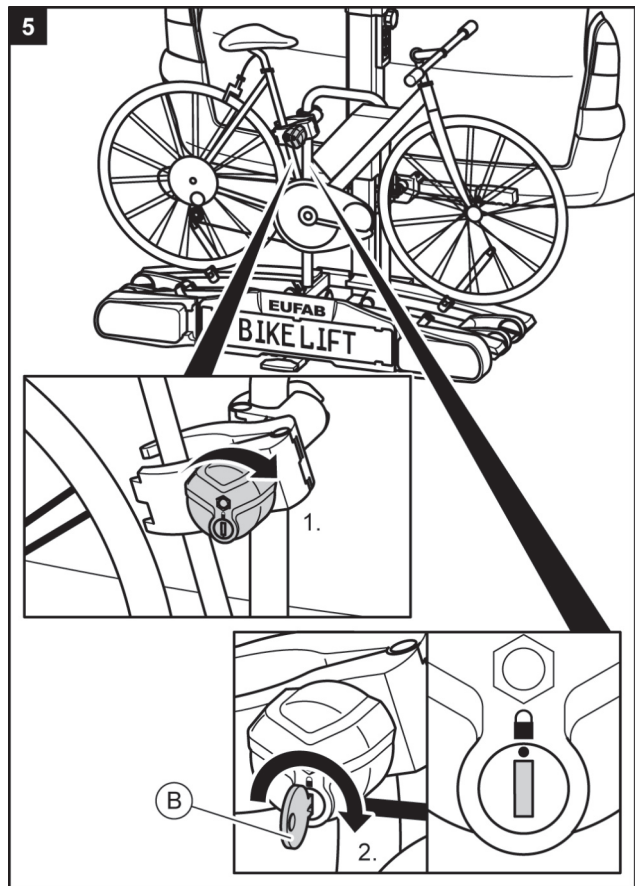
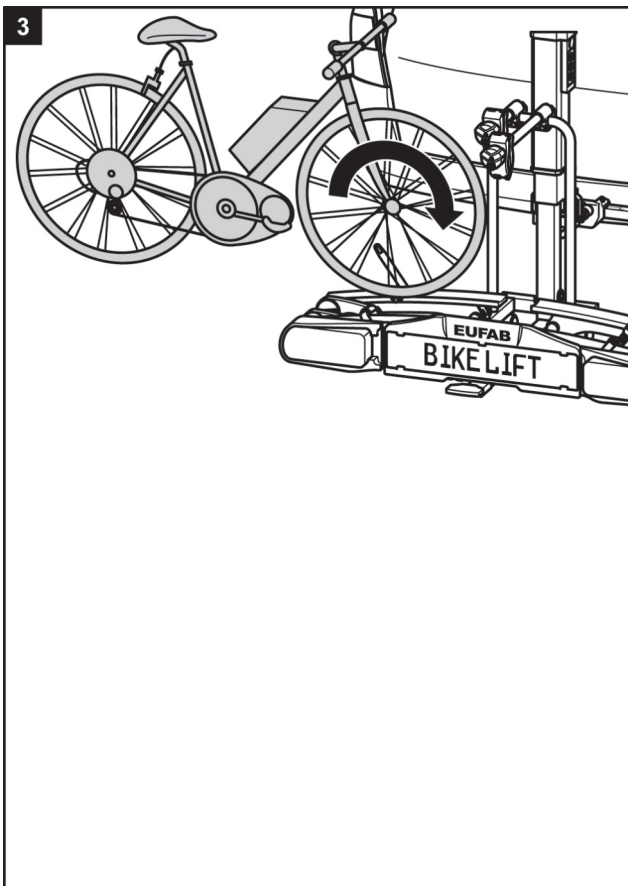

I Fissaggio delle biciclette

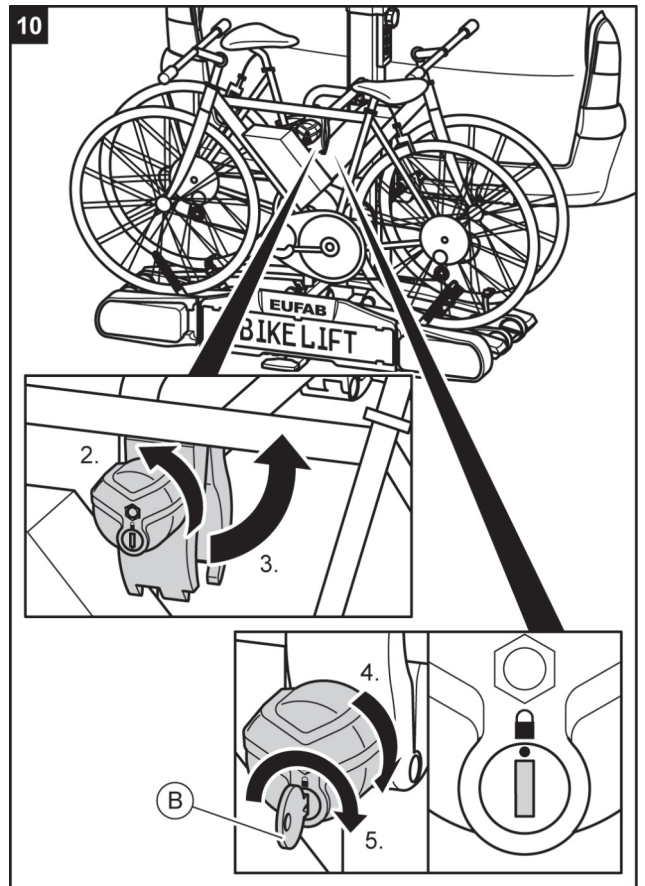
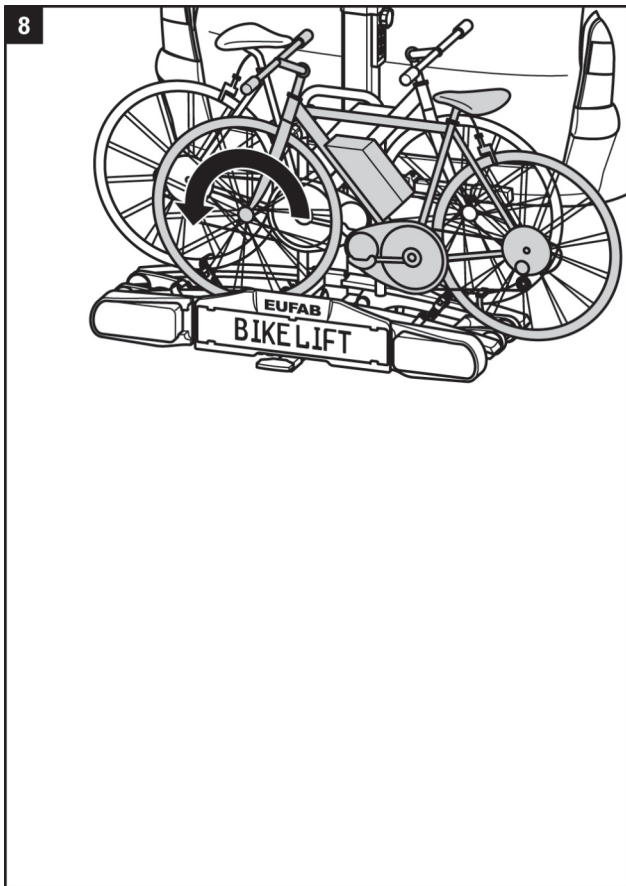
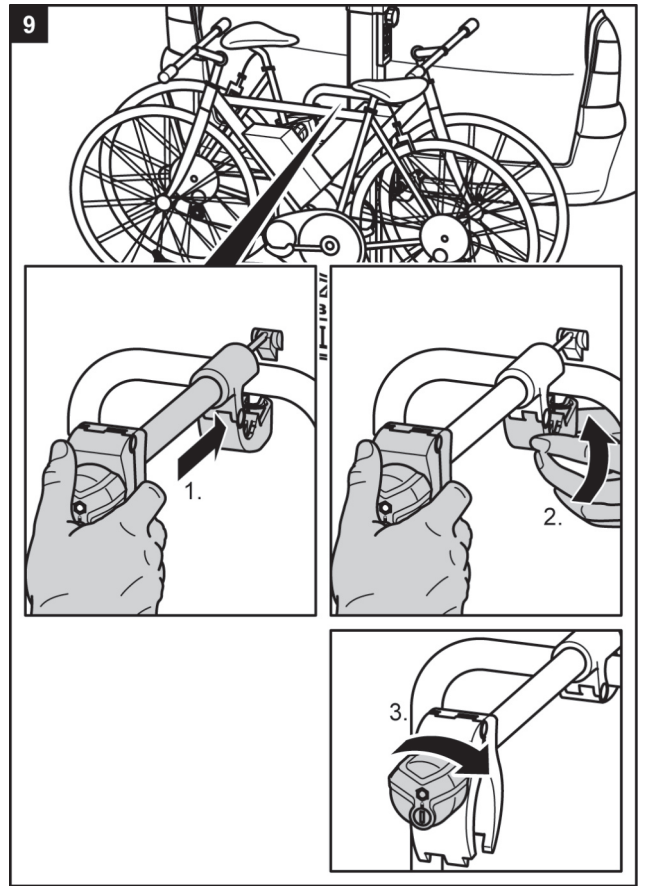
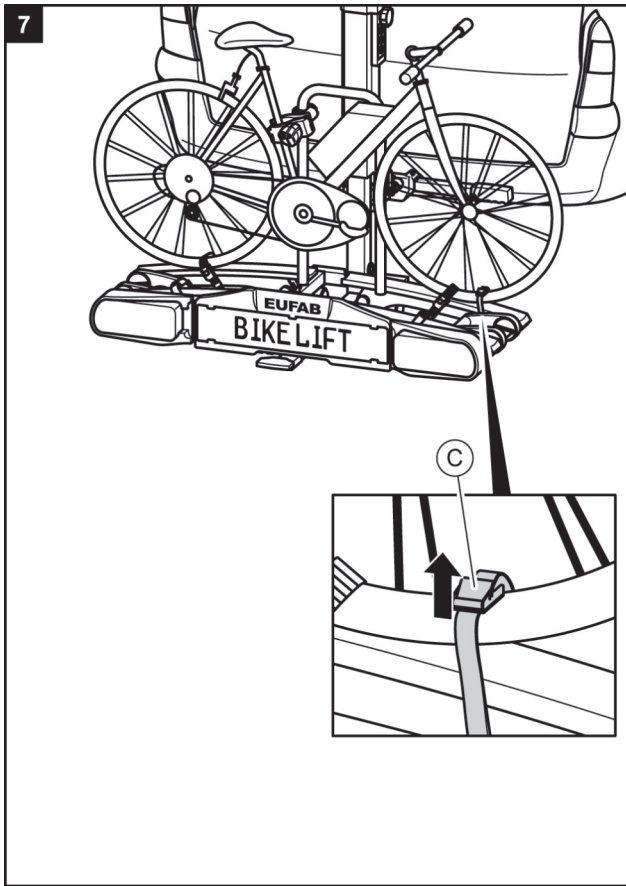

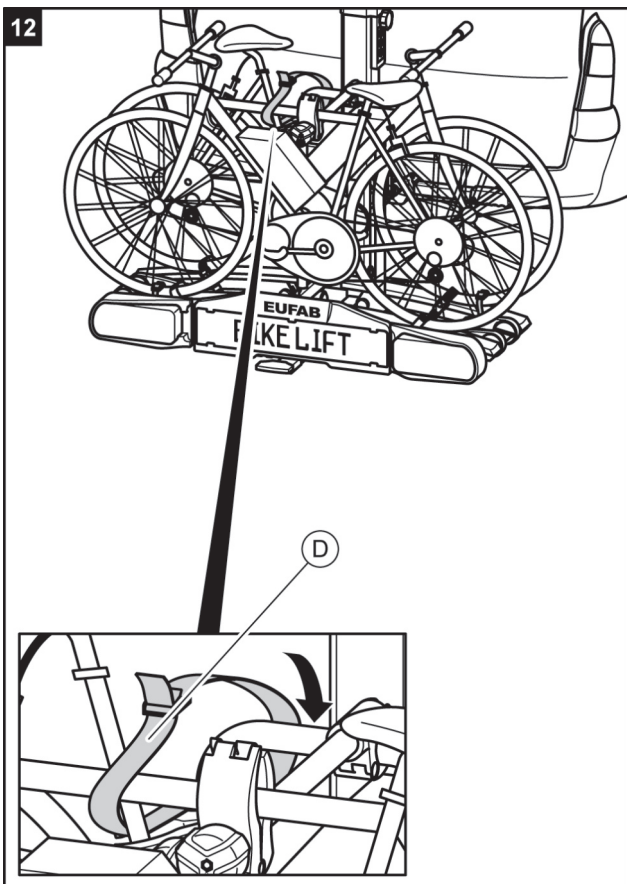
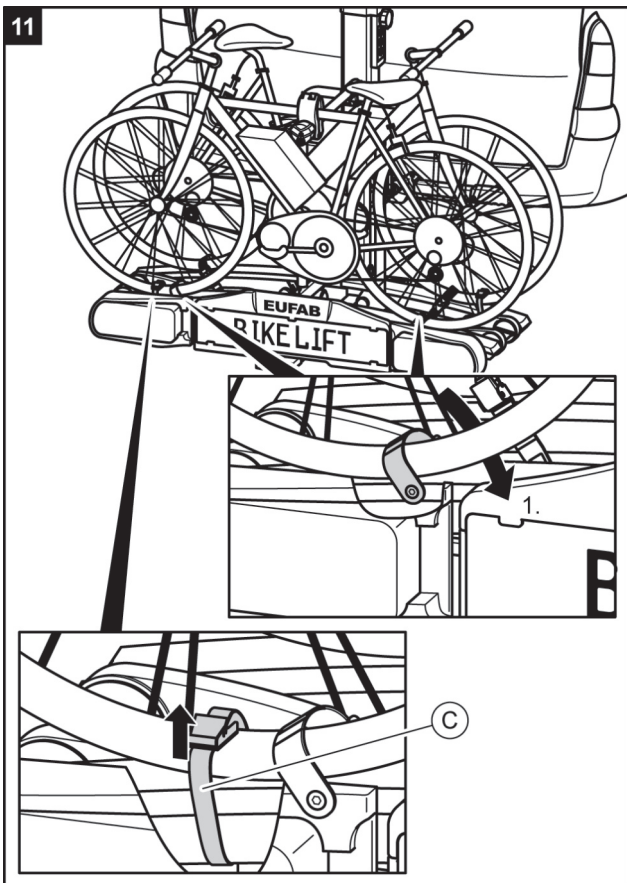

AVVERTENZA

Viaggiare senza cinghie di fissaggio può causare incidenti.

Lesioni personali o danni materiali in seguito alla perdita delle biciclette.

- ⇒ Prima di iniziare il viaggio, verificare che la cinghia sia fissata correttamente intorno alle biciclette e alla staffa a U del portabiciclette (vedere il passo 12 nel presente capitolo).
- ⇒ Prima di iniziare il viaggio, verificare il corretto fissaggio delle due cinghie intorno alla ruota anteriore e della cinghia intorno alla ruota posteriore della bicicletta.
- ⇒ Tendere ulteriormente le cinghie all'occorrenza.
- ⇒ Prima di iniziare il viaggio, assicurarsi che le cinghie utilizzate non siano danneggiate o usurate.
- ⇒ Prima di iniziare il viaggio, le cinghie danneggiate o usurate devono essere sostituite con altre in perfetto stato. È consentito solo utilizzare cinghie omologate da EAL GmbH



AVVERTENZA

Un collegamento lasco tra portabiciclette e bicicletta può causare l'allentamento del collegamento e la perdita della bicicletta.

Lesioni personali e danni materiali per la perdita di una bicicletta durante il viaggio.

- ⇒ Verificare che le biciclette siano fissate saldamente e correttamente.
- ⇒ Se il fissaggio è lento, seguire i passi da 1 a 12 del presente capitolo.

- ⇒ Sollevare ora il portabiciclette come descritto nel capitolo Sollevamento del portabiciclette.



AVVERTENZA

Un portabiciclette non sollevato o non fissato può restare impigliato a un ostacolo.

Lesioni personali o danni materiali in seguito alla perdita del portabiciclette durante il viaggio.

- ⇒ Prima di un viaggio, sollevare il portabiciclette fino alla posizione di fine corsa.
- ⇒ Fissare il portabiciclette con il perno di fissaggio, come indicato in "Sollevamento del portabiciclette".

Ripiegamento del portabiciclette, accesso al portabagagli

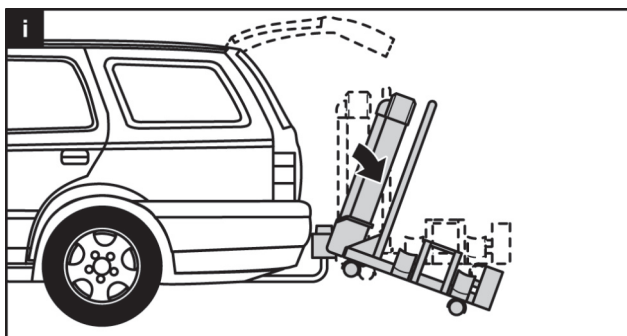

PRUDENZA

Il portellone posteriore potrebbe sbattere contro il portabiciclette e subire dei danni.
Danni materiali per l'apertura del portellone posteriore.

- ⇒ Disinserire il comando elettrico del portellone posteriore e impostare l'azionamento manuale.
- ⇒ Ripiegare il portabiciclette prima di aprire il portellone posteriore.



PRUDENZA

Lesioni personali e danni materiali per un abbassamento improvviso.

Eventuali parti del corpo e oggetti che dovessero trovarsi sotto o davanti al portabiciclette durante l'abbassamento, rischiano di essere schiacciati.

- ⇒ Assicurarsi che sotto il portabiciclette non ci sia nulla.
- ⇒ Fare attenzione al proprio corpo, specialmente alla testa, e mantenere una distanza di sicurezza.
- ⇒ Aprire il sistema di blocco (1.) Tenere saldamente il portabiciclette per la staffa (2.) durante l'abbassamento. Aprire il sistema di blocco (3.) con il piede e abbassare il portabiciclette con la mano.

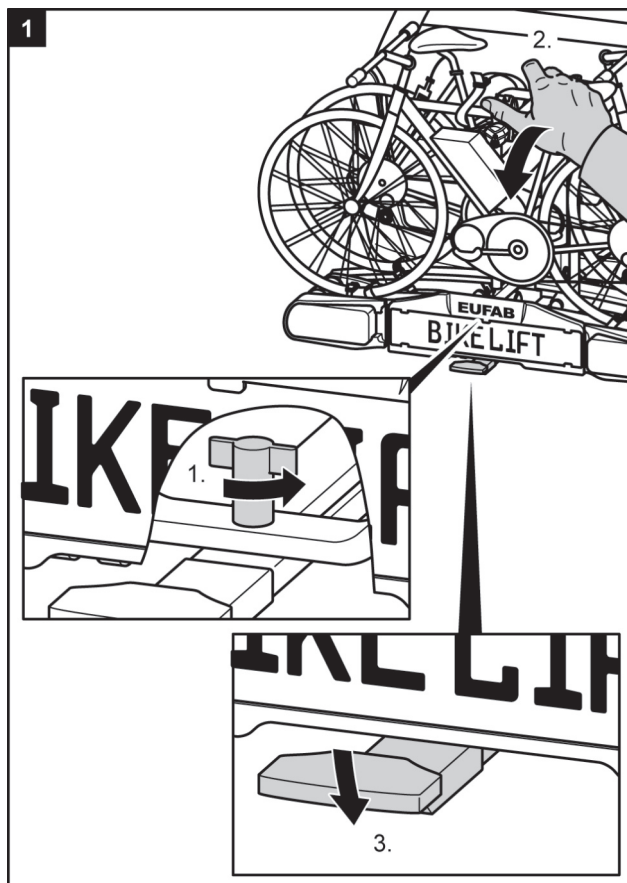

PRUDENZA

Pericolo di lesioni personali e danni materiali in seguito a ribaltamento.

Eventuali parti del corpo o oggetti che dovessero trovarsi tra il portabiciclette e il veicolo, rischiano di essere schiacciati.

- ⇒ Assicurarsi che tra il portabiciclette e il veicolo non ci sia nulla.
- ⇒ Togliere tutto quello che si trova tra il portabiciclette e il veicolo.

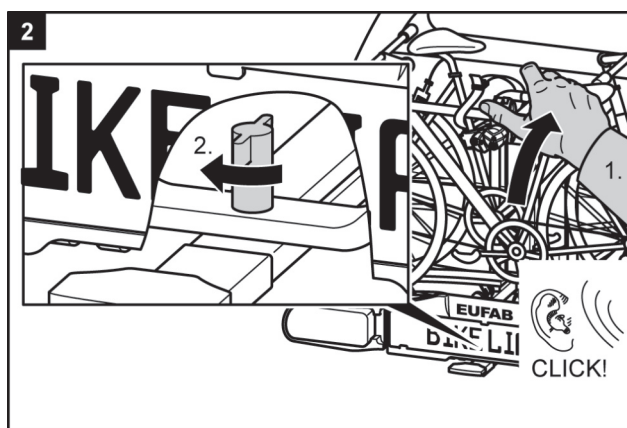

**AVVERTENZA**

Un portabiciclette non risollevato correttamente può staccarsi o causare il distacco del gancio di traino.

Pericolo di lesioni personali o danni materiali in seguito alla perdita del portabiciclette durante il viaggio.

- ⇒ Risollevarlo il portabiciclette prima del viaggio.
- ⇒ Assicurarsi che il portabiciclette sia scattato in posizione. Far scattare in posizione il portabiciclette come descritto in precedenza.

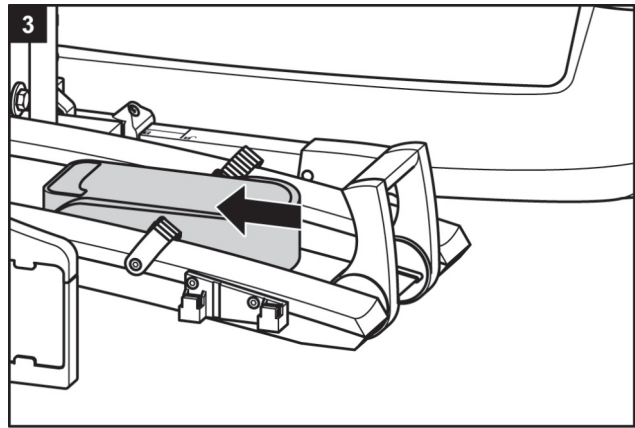
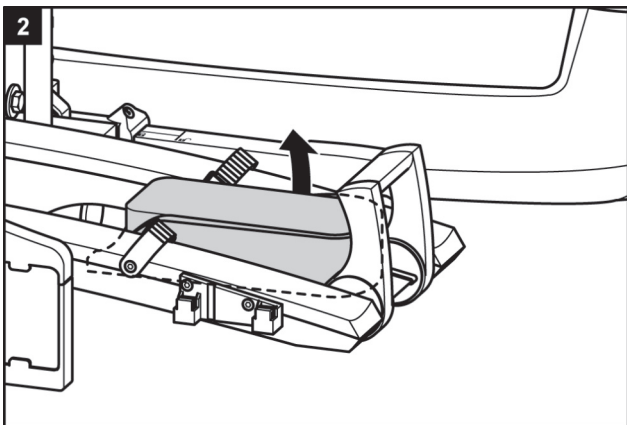
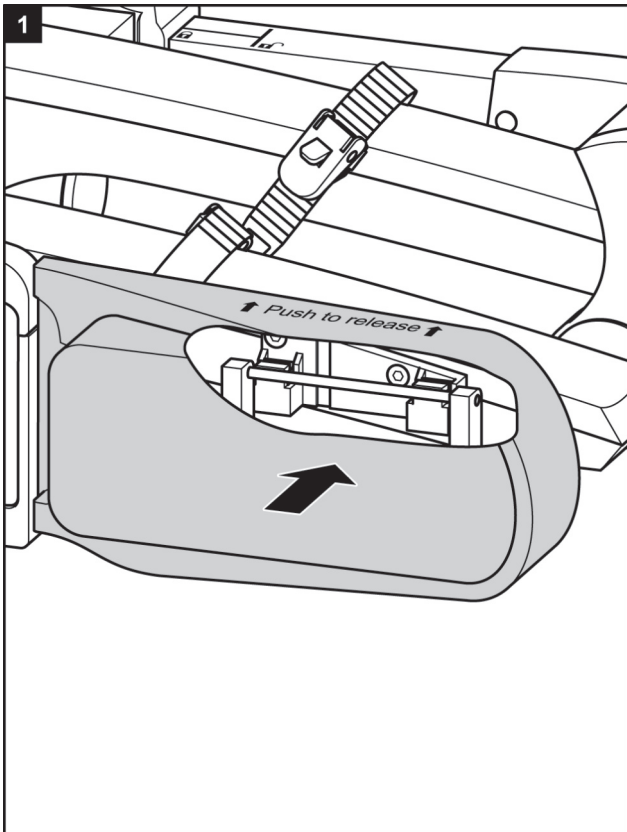
Smontaggio del portabiciclette

- ⇒ Per prima cosa, svitare il perno di bloccaggio dietro il porta-targa.

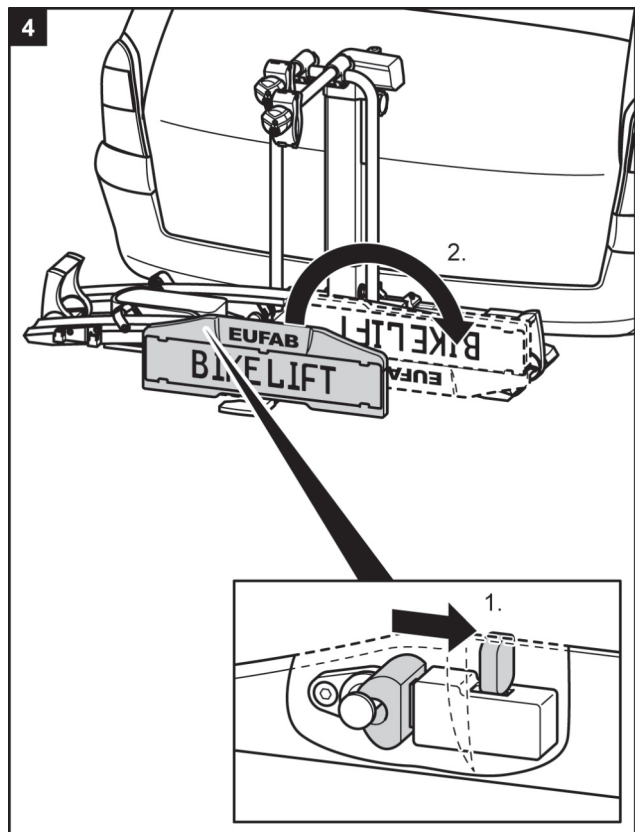

- ⇒ Per togliere il portabiciclette, procedere poi seguendo le fasi di montaggio in ordine inverso.

Trasporto del portabiciclette

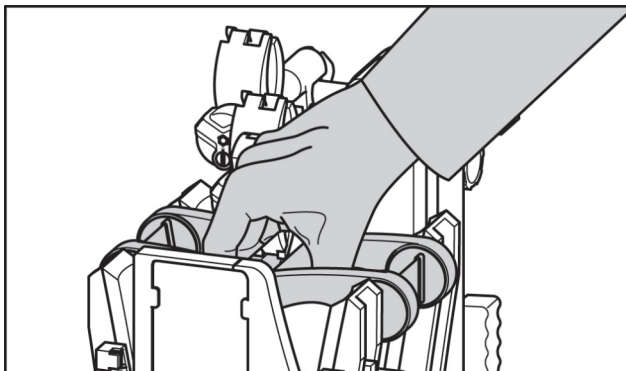

Movimentazione del portabiciclette su ruote

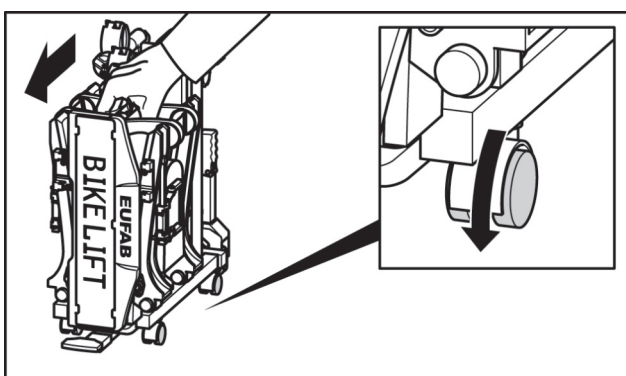

Sistemazione del portabiciclette nell'involucro di protezione

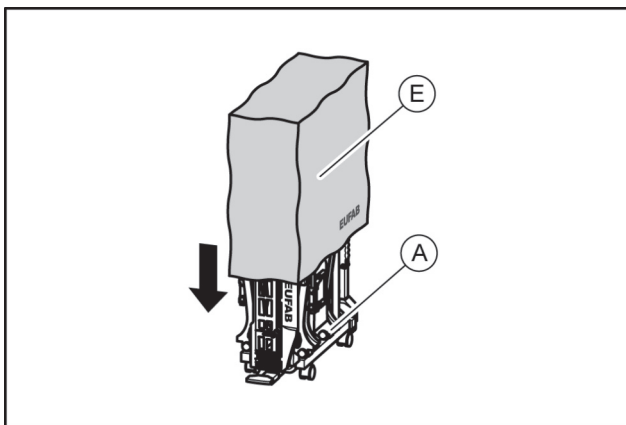

Pulizia e cura

Il portabiciclette può essere pulito con un detergente delicato, acqua calda e/o un panno morbido.

Togliere dapprima lo sporco grossolano e la polvere. Non usare solventi o detersivi simili, perché potrebbero danneggiare il portabiciclette.

Lasciare asciugare il portabiciclette all'aria. Non usare asciugacapelli o altri riscaldatori per accelerare il processo di asciugatura. Nelle zone costiere e in inverno, pulire il portabiciclette regolarmente, per rimuovere il sale e prolungarne la durata.

Se si prevede di non utilizzarlo per lunghi periodi (ad es. in inverno), stivare il portabiciclette in un luogo asciutto e protetto, per prolungarne la durata.

Manutenzione

Prima di iniziare il viaggio, controllare se il portabiciclette è usurato. Devono essere sostituite soprattutto le parti metalliche e le cinghie di fissaggio difettose.

Per la sostituzione dei pezzi, rivolgersi al nostro servizio di assistenza clienti.

Qualsiasi modifica dei pezzi originali e dei materiali o della struttura, può pregiudicarne la sicurezza e l'efficienza del portabiciclette.

Le parti in acciaio del portabiciclette sono state protette, in fabbrica, con una verniciatura a polvere anticorrosione. Se questo strato di vernice è danneggiato, provvedere tempestivamente a una rimozione professionale del danno.

In condizioni normali, il portabiciclette deve essere solamente pulito e non richiede manutenzione.

Regolazione dell'aggancio rapido

Eseguire questo tipo di manutenzione, solo se non si riesce a fissare il portabiciclette al gancio di traino, così come descritto nel capitolo Montaggio.

- ⇒ Staccare il portabiciclette dal gancio di traino, come descritto in "Smontaggio".
- ⇒ Togliere il cappuccio antipolvere.
- ⇒ Allentare il controdamo come da illustrazione.
- ⇒ Avvitare la vite di regolazione di un quarto di giro.
- ⇒ Serrare il controdamo.
- ⇒ Verificare che il portabiciclette sia perfettamente fissato al gancio di traino, come descritto nel capitolo Montaggio. In caso negativo, ripetere le fasi sopra descritte.

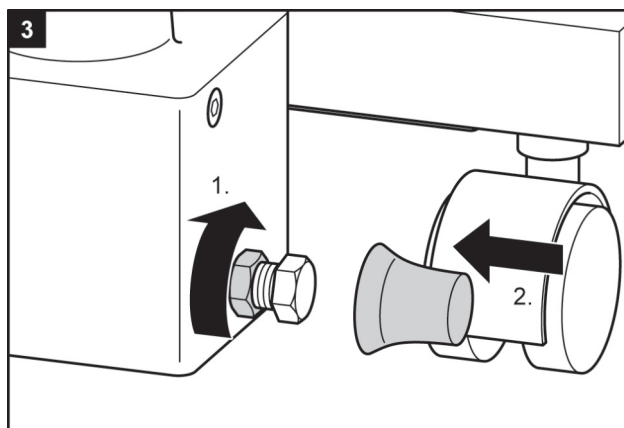
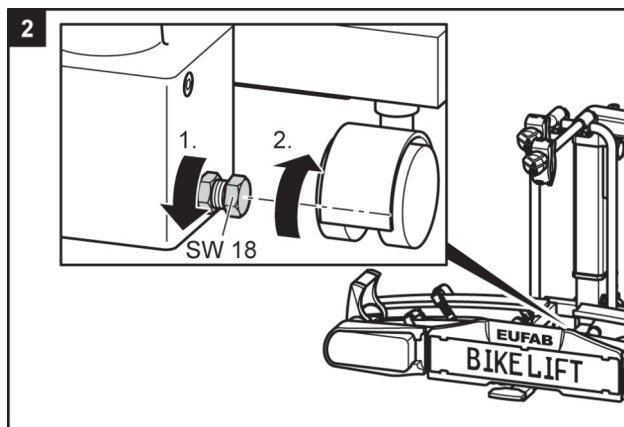
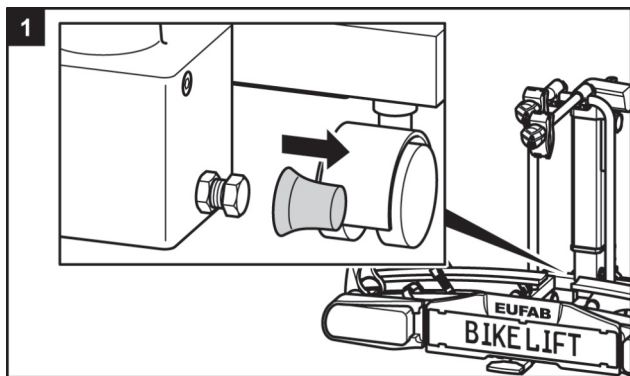

Smaltimento

Per lo smaltimento si devono rispettare le disposizioni amministrative locali.

Smaltire anche l'imballaggio negli appositi contenitori per la raccolta differenziata.

Per maggiori informazioni rivolgersi ai punti raccolta comunali.

Contatti

EAL GmbH
Otto-Hausmann-Ring 107
42115 Wuppertal
GERMANY

Telefono: +49 (0) 202 4292830
Fax: +49 (0) 202 42928320
Email: info@ealvertrieb.com

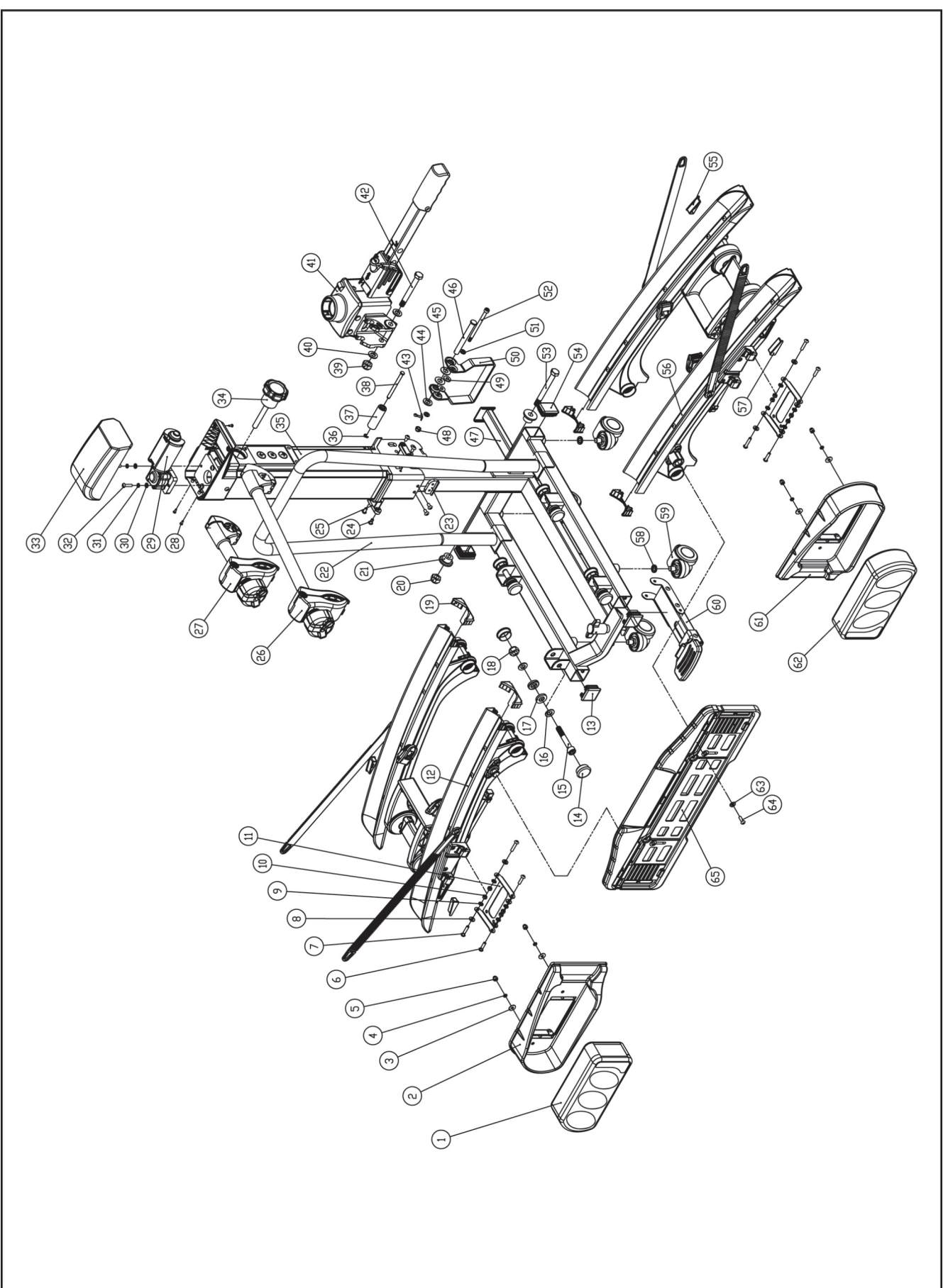

Pos.	Menge	Bezeichnung
1	1	Lamp complete right
2	1	Lamp guard right
3	4	Washer M5
4	4	Spring washer M5
5	4	Capped nut M5
6	4	Screw M5X20
7	4	Screw M5X25
8	8	Nylon washer M5
9	8	Washer M5
10	8	Self-locking nut M5
11	2	Lamp countersink
12	1	Left wheel rail with tension belt and carrier handle
13	2	Stopper for Nr.22,35X35mm
14	8	Round stopper for Nr.12
15	4	Bolt M10X65
16	8	Washer M10
17	8	Nylon washer M10
18	4	Self-locking nut M10
19	4	End cap aluminium rail interior
20	1	Self-locking nut M10
21	2	Stopper bearing pad
22	1	Carrier table bracket and U-bracket
23	1	Small plastic stopper 1
24	6	Screw M5X10
25	2	Small plastic stopper 2
26	1	Lock bracket long
27	1	Lock bracket short
28	4	Screw ST 2.9X9.5
29	1	Motor
30	2	Washer M5
31	2	Spring washer M5
32	2	Screw M5X20
33	1	Plastic cover for lift bracket

Pos.	Menge	Bezeichnung
34	1	Safety pin
35	1	Lift bracket
36	1	Jump ring
37	1	Nylon roller
38	1	Pin ø6
39	1	Self-locking nut M10
40	2	Washer M10-2.0
41	1	quick release
42	1	Bolt M10X87
43	1	Split pin ø3.2X25
44	2	Washer M10-2.0
45	2	Big washer M10-1.2
46	1	Pin ø10
47	1	Push rod
48	1	Self-locking nut M6
49	2	Big washer M6-1.2
50	1	Tilting operator
51	2	Washer M6-1.6
52	1	Bolt M6X85
53	1	Bolt M10X95
54	2	Stopper for Nr.22,30X40mm
55	2	Triangle end cap 1
56	1	right wheel rail with tension belt and carrier handle
57	2	Triangle end cap 2
58	4	Spring washer M10
59	4	Universal castor
60	1	Kick plate for locking mechanism
61	1	Lamp guard left
62	1	Lamp complete left
63	1	Nylon washer M5
64	1	Screw M5X16
65	1	Registration plate bracket

Configurazione dei connettori

Il portabiciclette è dotato di un impianto d'illuminazione. Questo viene collegato con un connettore a 13 poli alla presa del gancio di traino. Se un veicolo è equipaggiato con un attacco a 7 poli, invece di uno a 13 poli, di seguito è illustrata la configurazione corretta. Tali informazioni sono pensate solo per una trasformazione da parte di un'azienda specializzata. Non è consentita una trasformazione da parte di persone non addestrate.

13 poli

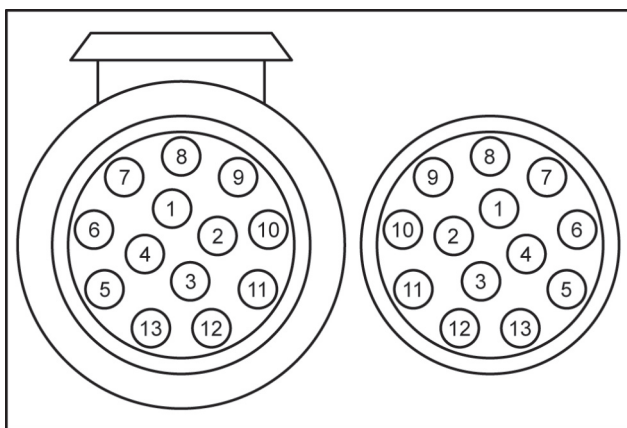

1	Indicatore di direzione sinistro	giallo
2	Luce posteriore antinebbia	blu
3	Massa	bianco
4	Indicatore di direzione destro	verde
5	Luce posteriore destra	marrone
6	Luci di arresto	rosso
7	Luce posteriore sinistra	nero
8	Luce di retromarcia	grigio
9	+12 V per sistema di sollevamento	rosso
10	Non assegnato	–
11	Non assegnato	–
12	Non assegnato	–
13	0 Massa per sistema di sollevamento	nero

EAL GmbH
Otto-Hausmann-Ring 107
42115 Wuppertal
GERMANY