

Instrucciones de montaje
Assembly instructions
Instructions de montage
Montageanleitung

Pitarch
SYSTEM KIT MUEBLES



REF. 1049 // 10049 // 14049

Te aconsejamos/ We advise you / Nous vous recommandons / Wir beraten Sie

Ordena y cuenta las piezas y herrajes

Habilita una zona para el montaje

No fuerces los tornillos y los elementos de montaje

Sigue paso a paso las instrucciones de montaje

Order and count the parts and fittings

Enable an area for assembling.

Do not force the screws or assembly parts

Follow the assembly instructions step by step

Commander et compter les pièces et accessoires

Mettre en place un espace de rassemblement

N'utilisez pas de force sur les vis ou les éléments de montage

Suivre les instructions de montage étape par étape

Ordnen und zählen Sie die Teile und Armaturen

Einen Bereich für die Montage einrichten



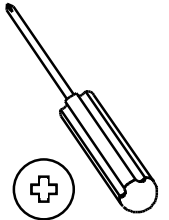
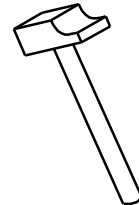
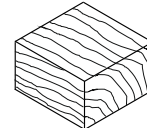
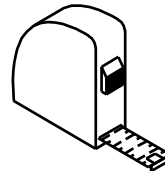
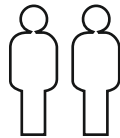

Wenden Sie keine Gewalt auf Schrauben oder Befestigungselemente an.

Folgen Sie der schrittweisen Montageanleitung

Herramientas necesarias/ Tools required / Les outils nécessaires / Notwendige Werkzeuge

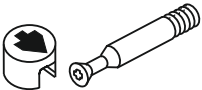
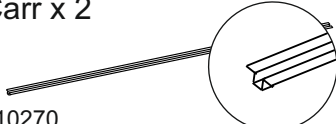

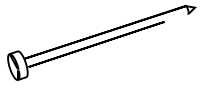
Herrajes incluidos/ Fittings included / Matériel inclus / inklusive Hardware

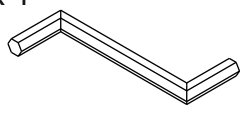
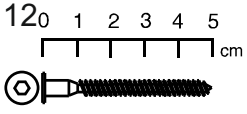
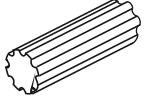
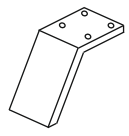
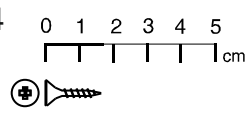
<p>Excgr x 20</p>  <p>721016/721017</p>	<p>Carr x 2</p>  <p>710270</p>	<p>Tirad x 1</p>  <p>722030</p>	<p>Pun x 40</p>  <p>720007</p>
<p>Rued x 2</p>  <p>710003</p>	<p>Sali x 2</p>  <p>710004</p>	<p>Lzpq x 1</p>  <p>721051</p>	<p>Autpq x 120</p>  <p>721050</p>
<p>Tap x 8</p>  <p>721308</p>		<p>Pat x 5</p>  <p>710273</p>	<p>Rei x 24</p>  <p>721020</p>

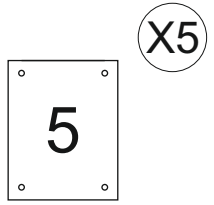
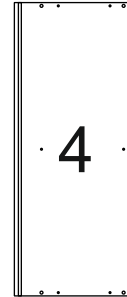
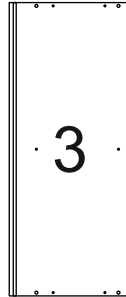
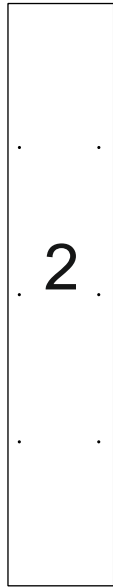
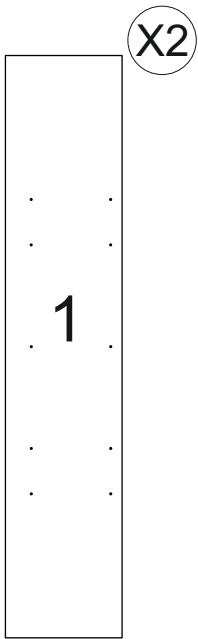

1642x329 mm
104910/1004910/
1404910

1642x298 mm
104950/1004950/
1404950

800x330 mm
104931/1004931/
1404931

800x330 mm
104932/1004932/
1404932

375x295 mm
104920/1004920/
1404920

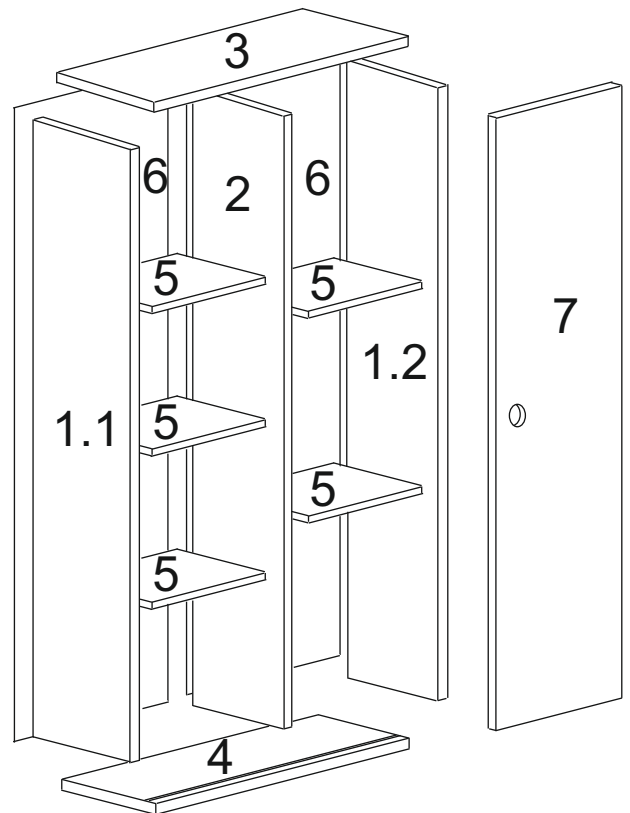
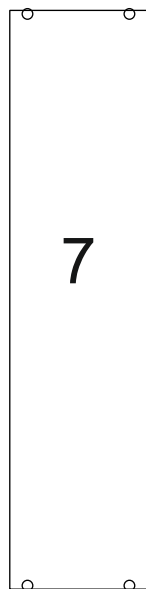
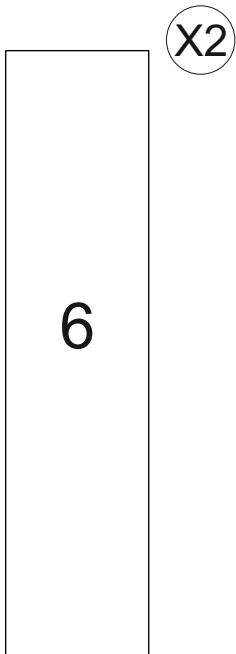

1672x396 mm
910495/9100495/
140495

1635x388 mm
104940/1004940/
1404940

1

Excgr x 10

Tap x 8

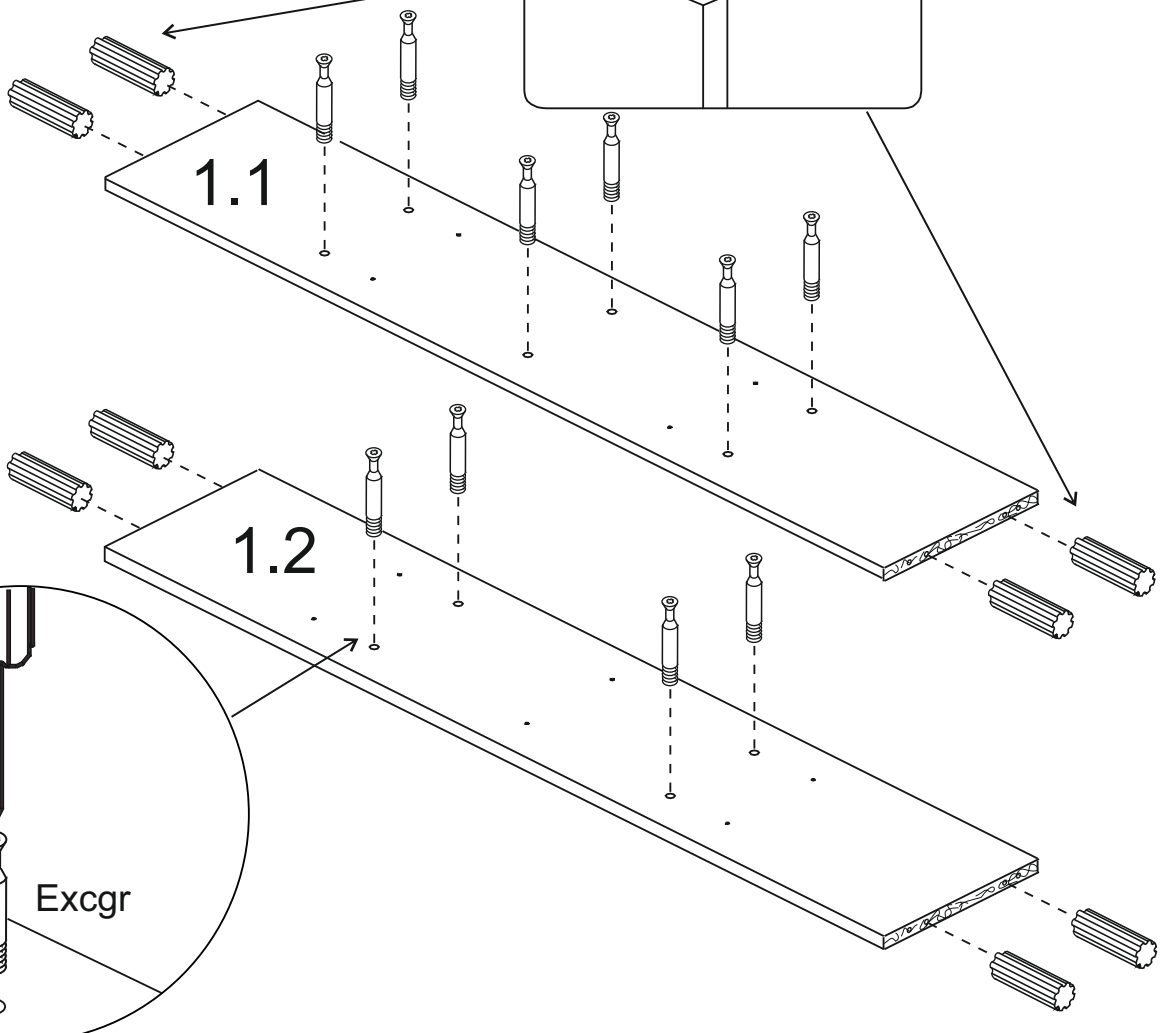
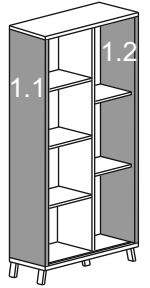
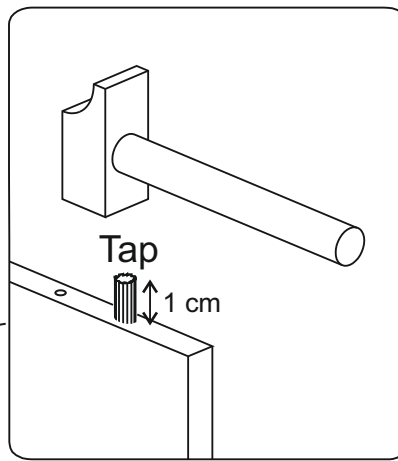
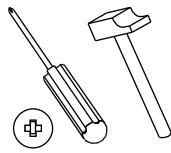

Excgr x 20

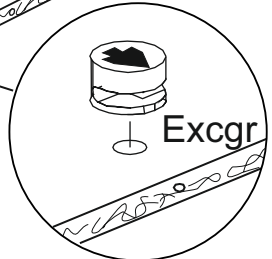
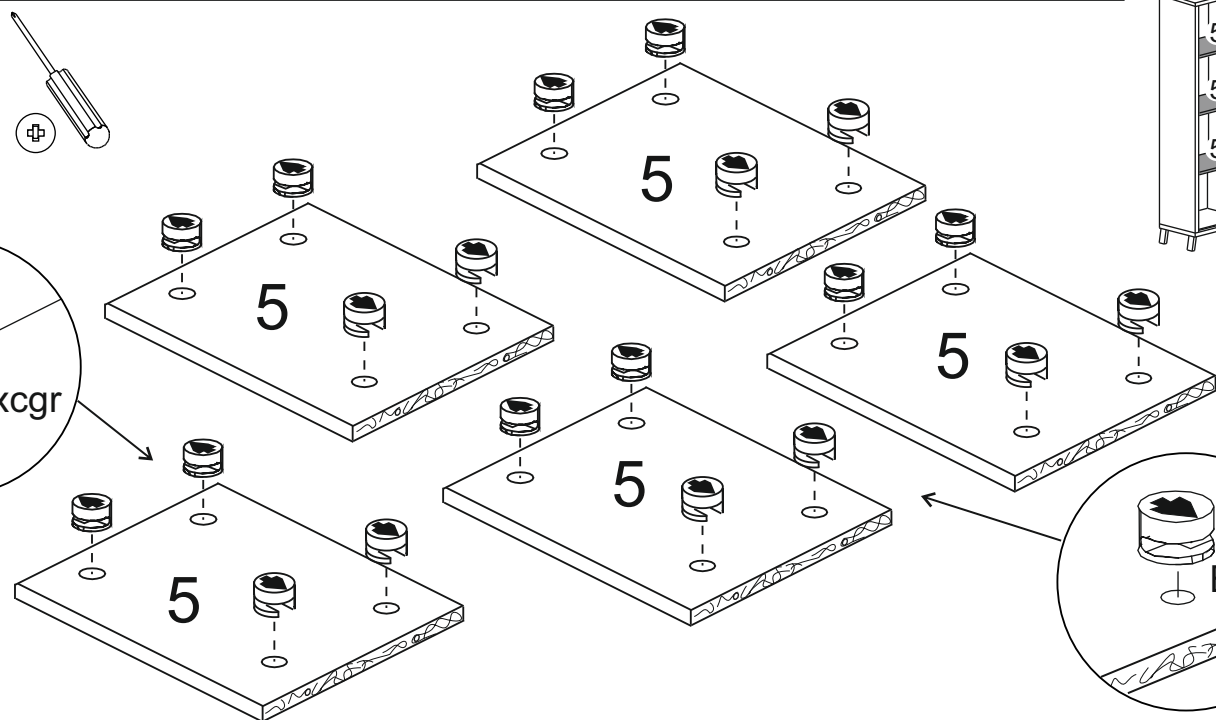
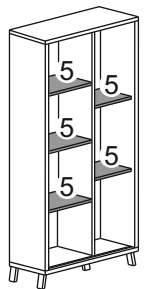
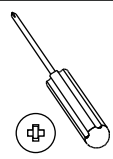

Excgr x 10

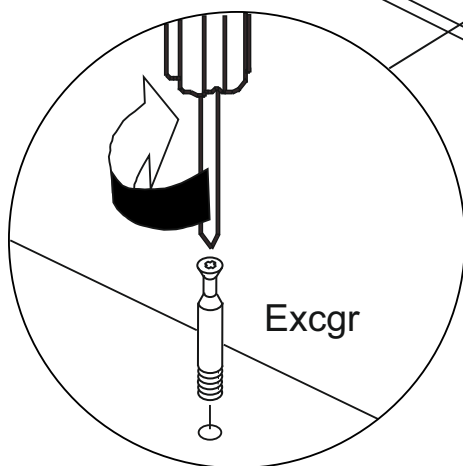
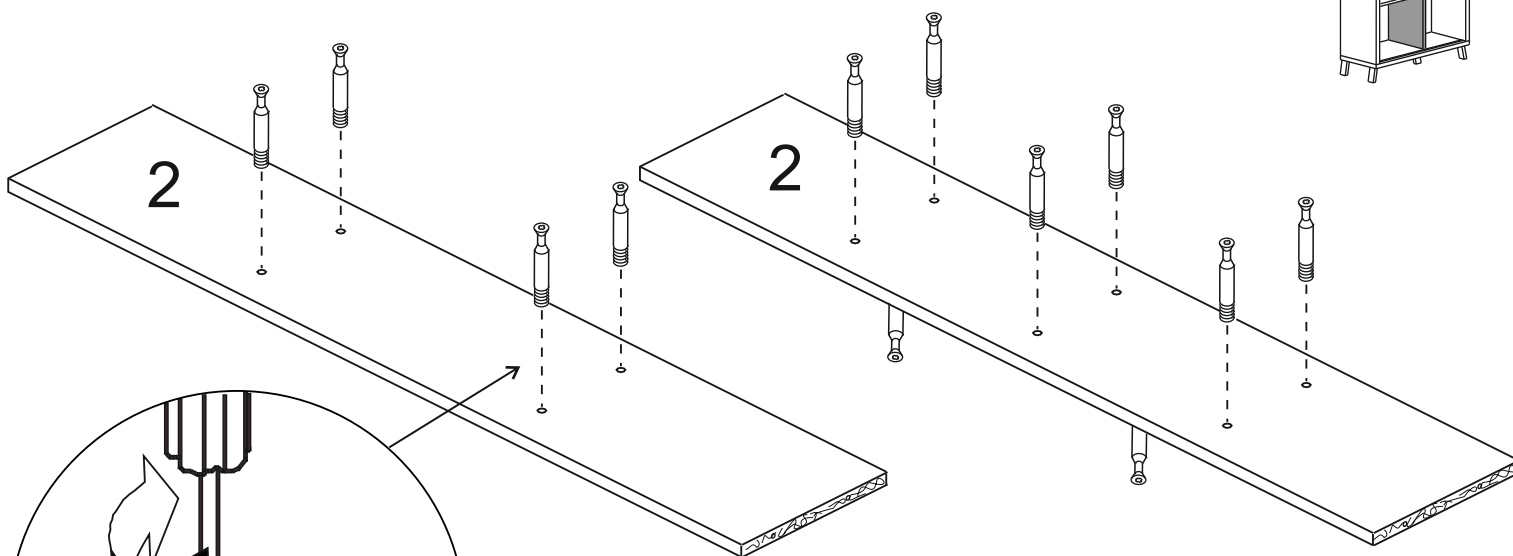
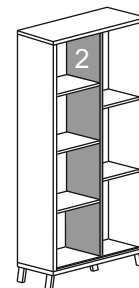
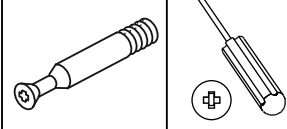

Carr x 2

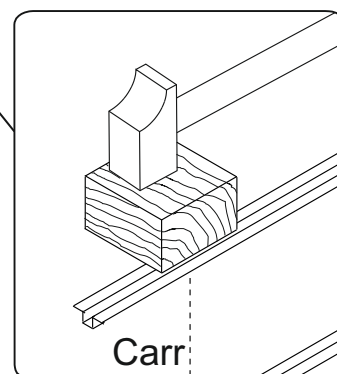
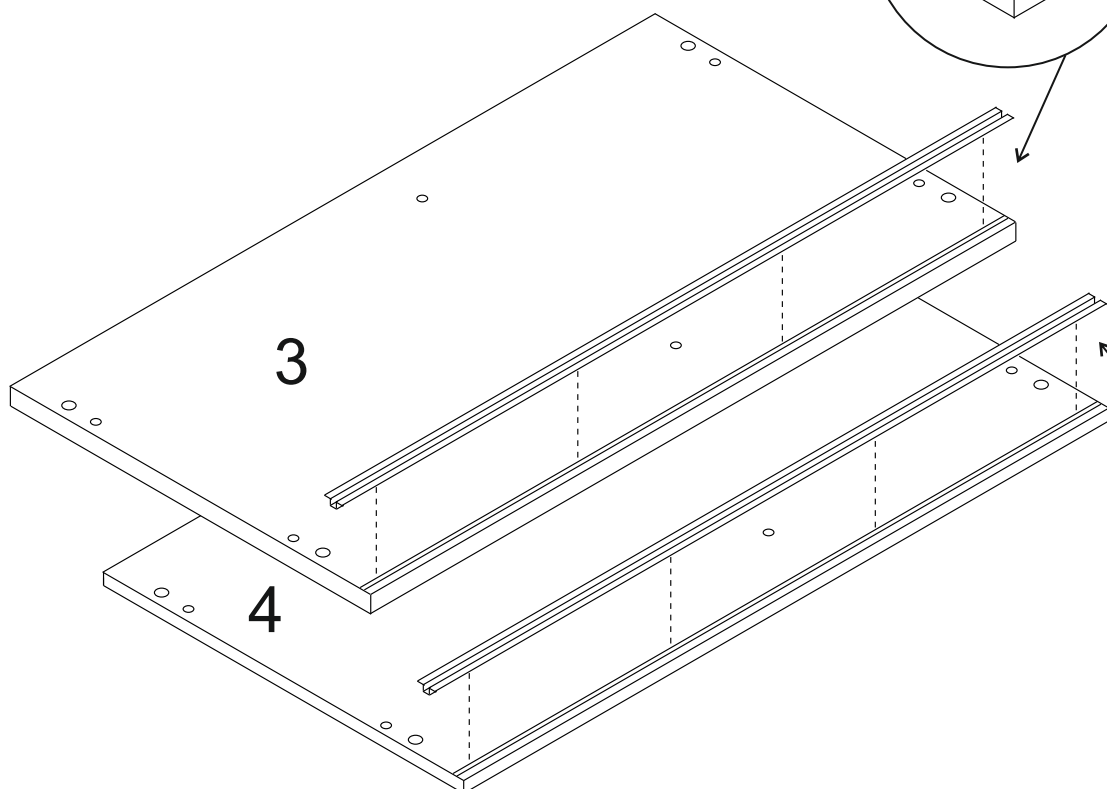
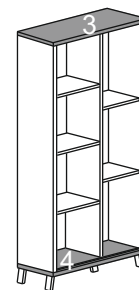
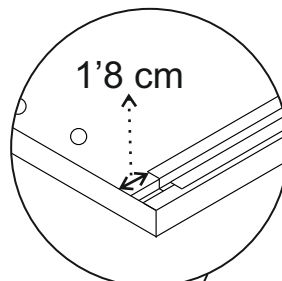
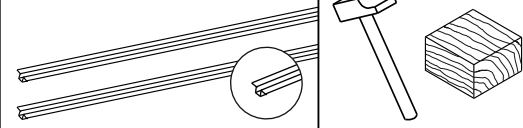

2

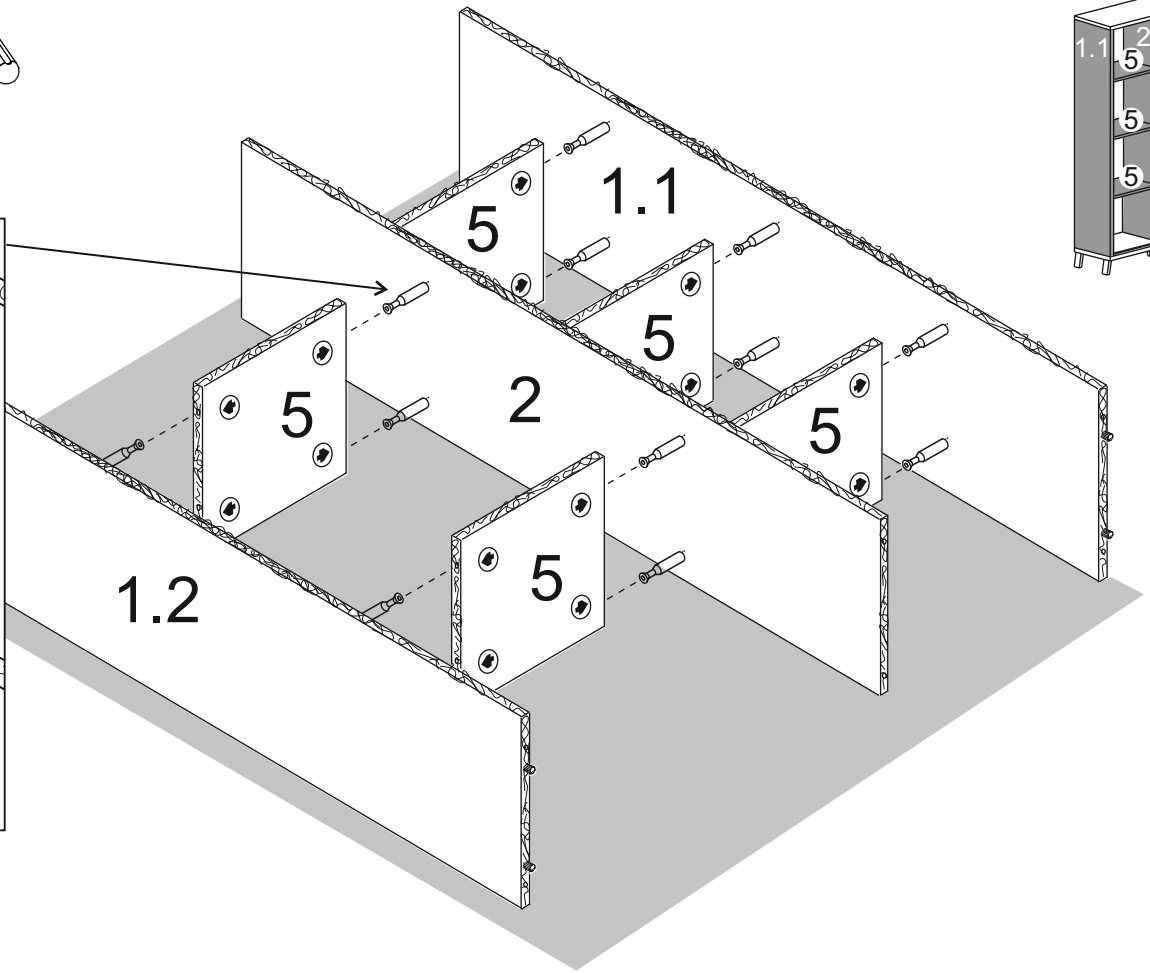
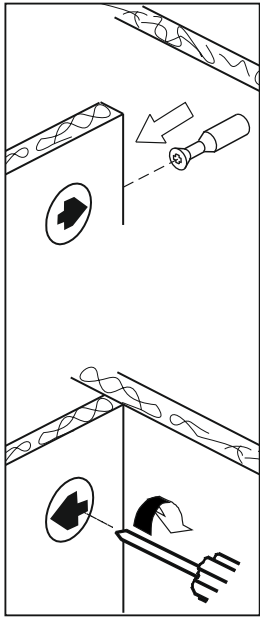
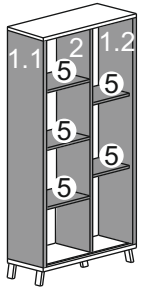
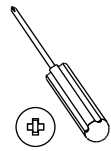

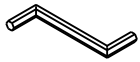

3

Lzpq x 1

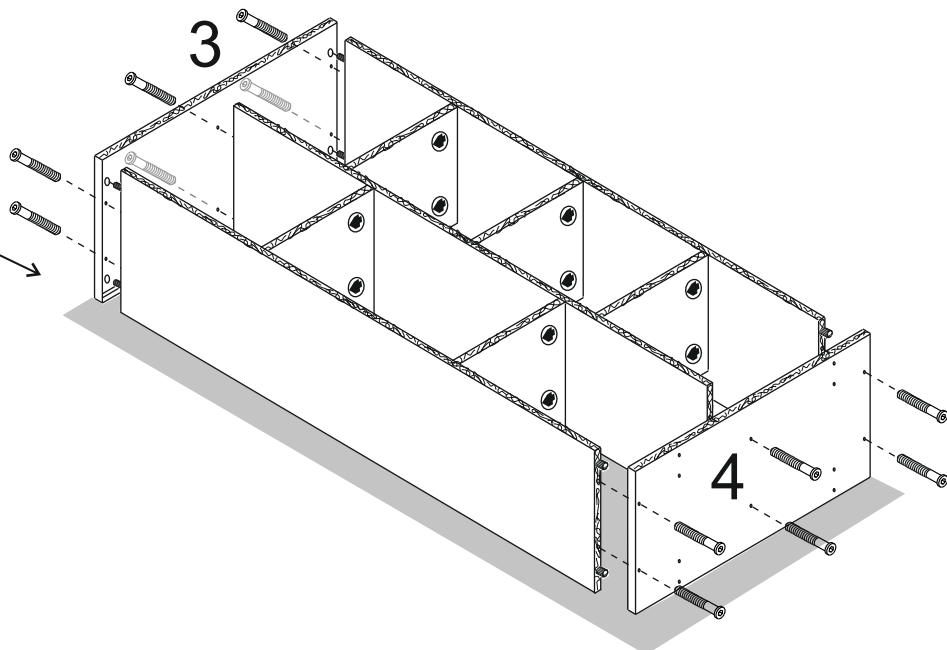
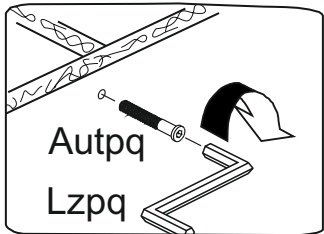
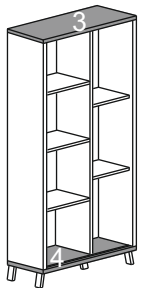

Autpq x 12

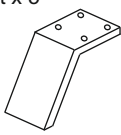

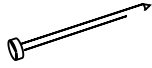

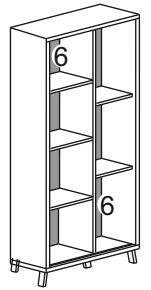
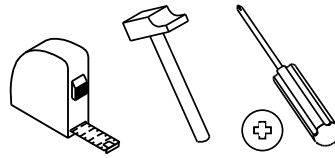

4	Pat x 5 	Rei x 20 	Pun x 40 
---	---	---	--

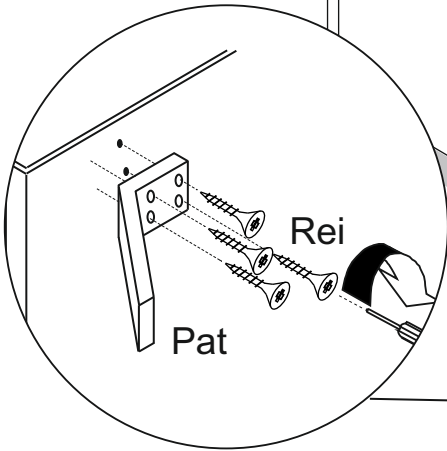
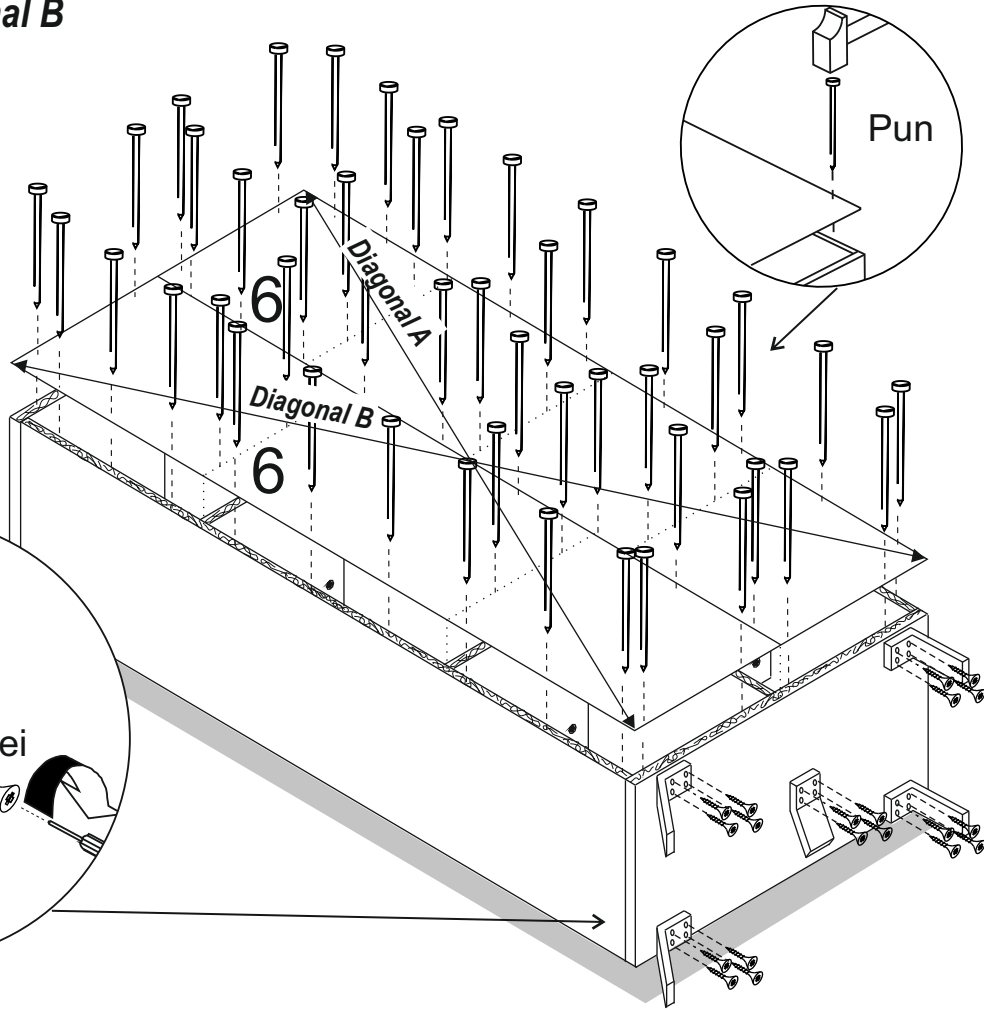

Diagonal A = Diagonal B

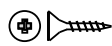

5	Sali x 2 	Rued x 2 	Rei x 4 	Tirad x 1 
---	---	---	--	--

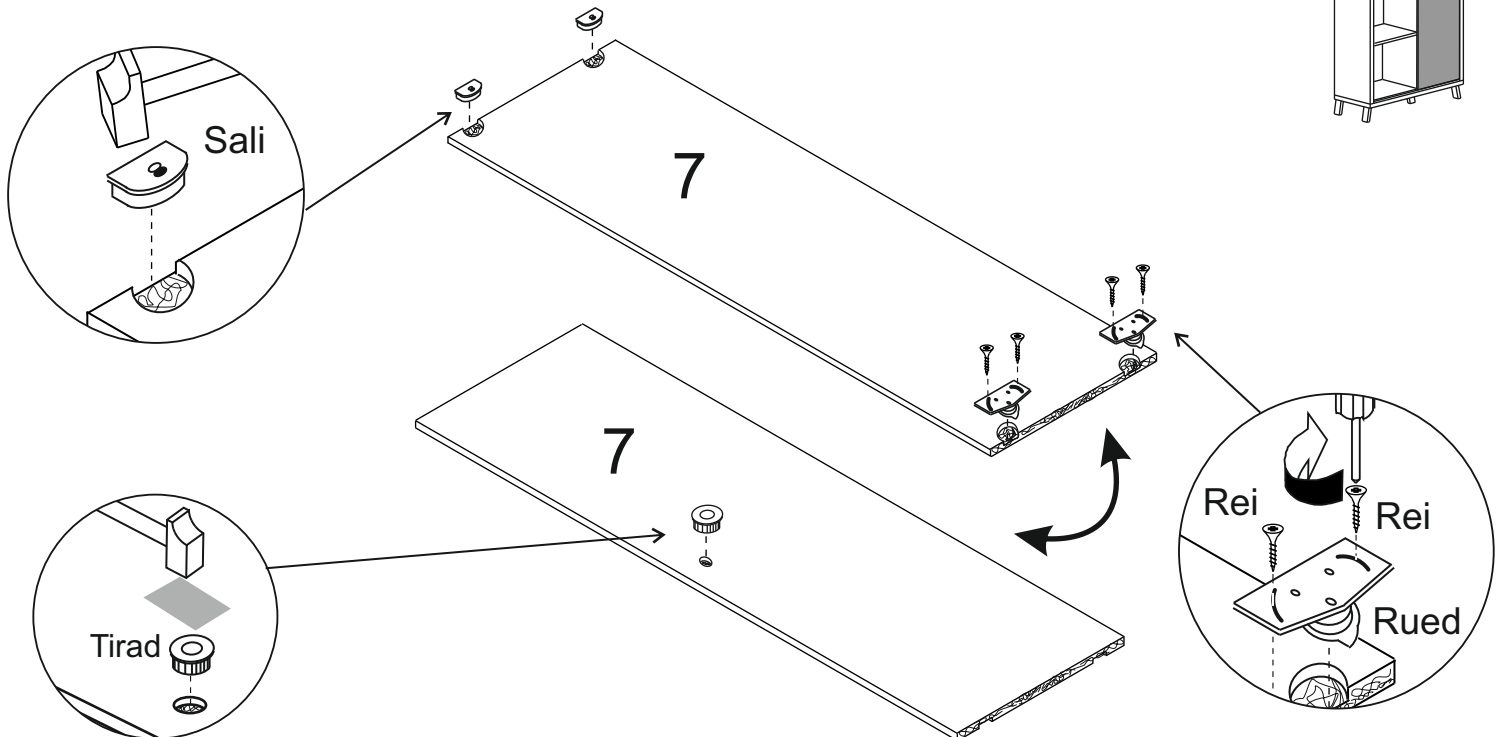
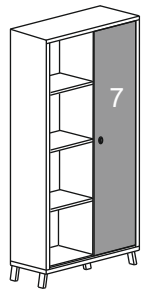
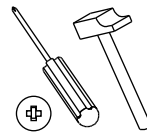

6

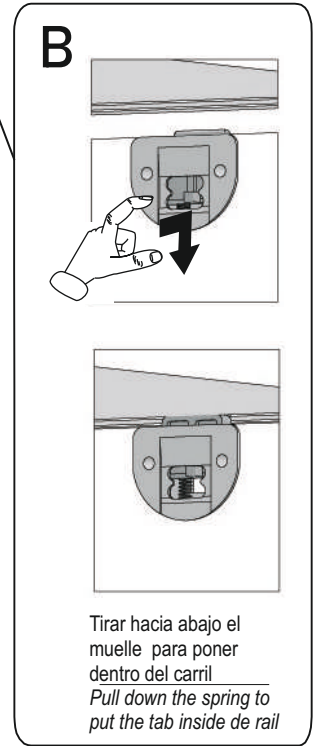
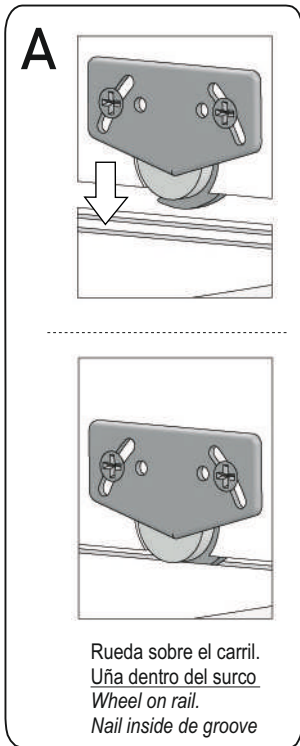
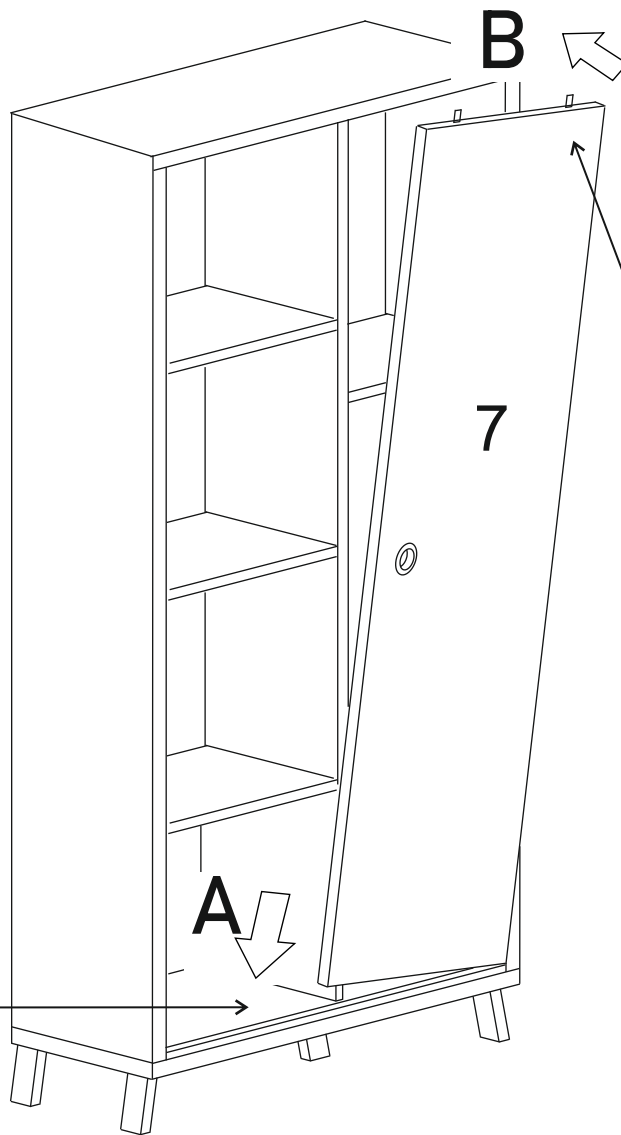

Regulación de puerta / Door adjustment

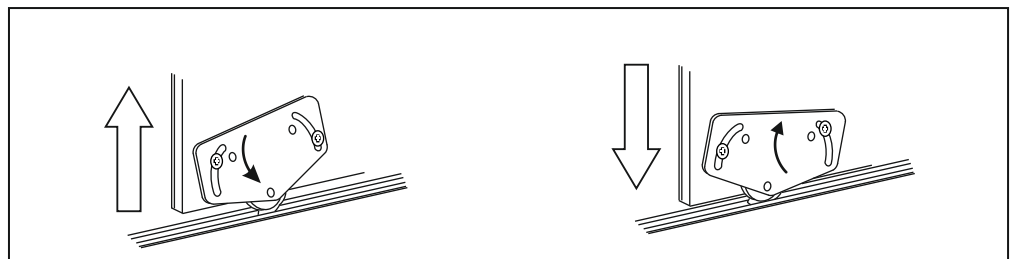

CONDICIONES DE USO Y MANTENIMIENTO

Producto de uso doméstico.
Evitar colocar el mueble cerca de fuentes de calor, de humedad o de una fuerte luz solar.
No lo limpie con productos abrasivos, ni disolventes.
Quitar el polvo antes de limpiarlo.
Utilizar un paño húmedo, limpio y sin pelos.

CONDITIONS OF USE AND MAINTENANCE OF FURNITURE

Product for domestic use only.
Avoid placing the furniture near sources of heat, damp, or strong sunlight.
Do not clean with abrasive products or cleaning products with solvents.
Use a dust remover before any cleaning process.
It is recommended to use a damp, lint-free clean cloth.

LES CONDITIONS D'UTILISATION ET D'ENTRETIEN

Produit à usage domestique.
Évitez de placer les meubles à proximité de sources de chaleur, d'humidité ou de forte lumière solaire.
Ne pas nettoyer avec des abrasifs ou des solvants.
Enlevez la poussière avant le nettoyage.
Utilisez un chiffon propre et humide.

EINSATZ- UND WARTUNGSBEDINGUNGEN

Produkt für den Hausgebrauch.
Vermeiden Sie die Aufstellung der Möbel in der Nähe von Wärmequellen, Feuchtigkeit oder starker Sonneneinstrahlung.
Reinigen Sie nicht mit Scheuermitteln oder Lösungsmitteln.
Entfernen Sie vor der Reinigung den Staub.
Verwenden Sie ein sauberes, feuchtes Tuch.

ATENCIÓN AL CLIENTE
CUSTOMER SUPPORT

(+34)964 321 111

8am-1pm 3pm-5:30pm Lunes a viernes
Monday to Friday

Web: www.mueblespitarch.com
e-mail: comercial@mueblespitarch.com

LOTE/BATCH NUMBER
5173/5175