

NEO protective pads: Our specially engineered NEO pads protect your TV from unwanted marks and scratches and also act as an extra layer of audio insulation preventing resonance and vibration from your speaker system from affecting your TV.

Triple Arms: The triple arm structure of your mount provides you with added strength and stability as well as improved maneuverability.

Shaped Arms: Concave shaped arms, precision designed by our experienced design team to deliver the best, strongest and most stable performance.

Spirit Level: Comes with an integrated spirit level to make installation accurate and more convenient.

Quick adjust lever: Raise the lever, adjust the tilt to the desired position then press the lever down. Simple and effortless allowing you to find the perfect viewing angle every time.

Attractive wall plate cover: Your mount effortlessly blends unobtrusively into any interior with the supplied wall plate cover.

Safety Locking screw: Peace of mind is guaranteed with our hard locking safety screw. Relax and enjoy your viewing without worry.

Multi colour design language: The new TV you just purchased is a work of art with or without a picture on the screen, Now your mount can be just as much a design feature as the TV its connected to!

5 Year Warranty: Our mounts are built to last. Each one comes with a 5 year warranty as standard.

Quality Construction: Made with the highest quality components and over a decade of experience.

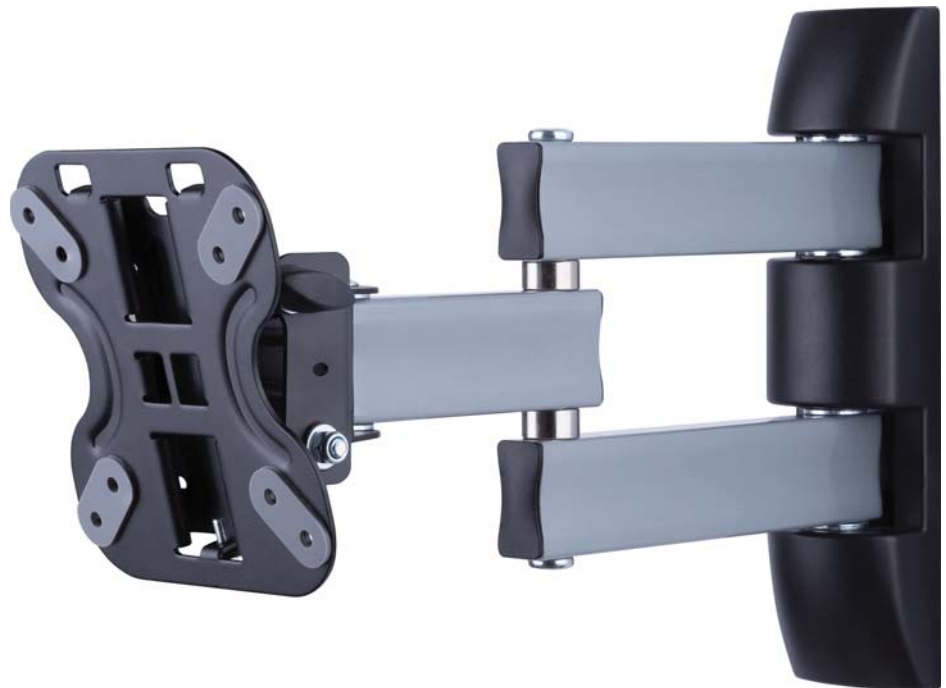

Technical Specifications:

Max Load	Distance from wall (Folded)	Distance from wall (Extended)	Swivel Range	Tilt Range	No of Articulation Points	Mounting Pattern	VESA Compatible
25Kg/ 55lbs	76mm/ 3.0"	358mm/ 14.1"	±90°	-5°/+15°	3	Single Stud & Solid Wall	75x75 to 100x100



Packed image



Line drawing

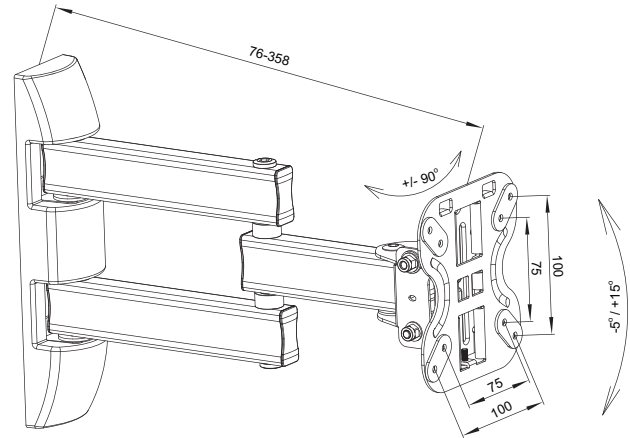

All dimensions are in mm

Packaging Information:

Product Number	Description	Product Packaging		Outer Packaging		
		Type	Barcode	Type	Qty in Box	Barcode
LN2TA100-RO	Triple Arm Full Motion TV Wall Mount	Colour Gift Box	5015056591766	Brown Outer with Label	4	5015056544373

Weight & Dimensions:

Product			Product Box			Outer Box		
Extended	Folded	Net Weight	Dimensions	Gross Weight	Cubic	Dimensions	Gross Weight	Cubic
25.5 x 12 x 35.8 cm	25.5 x 21.4 x 7.6 cm	1.93kg	27.5 x 21.5 x 7.5 cm	2.11kg	0.0044m ³	44.5 x 30 x 18 cm	8.94kg	0.0240m ³
10.04" x 4.72" x 14.09"	10.04" x 8.43" x 2.99"	4.246lbs	10.83" x 8.46" x 2.95"	4.642lbs	0.1566ft ³	17.52" x 11.81" x 7.09"	19.668lbs	0.8486ft ³